

29RVHD

A Combination You Cannot Beat

SERIES 2

See snoway.com application guide.

You **MUST** see your retailer or check online application guide for current truck application information

The 29RVHD is a combination you cannot beat for moving the most snow. This Flared wing V-plow with patented hydraulic end wings and Down Pressure[®] has the greatest possible snow moving flexibility and capacity for your plow truck. It has the patented Ground Hugger[™] blade with the MaxAdjust[™] Leveling system that keeps the plow on the ground to eliminate snow trails.



MAXIMUM SNOW MOVING CAPACITY

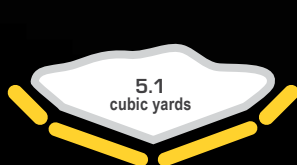

29RVHD at 15°



29RVHD at 30°

DOWNPRESSURE[®] STANDARD

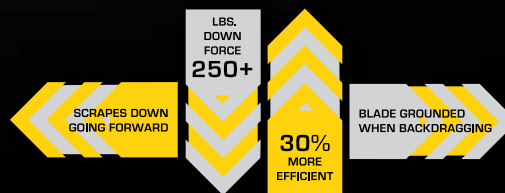

FEATURES

29RVHD SERIES 2 SPECS

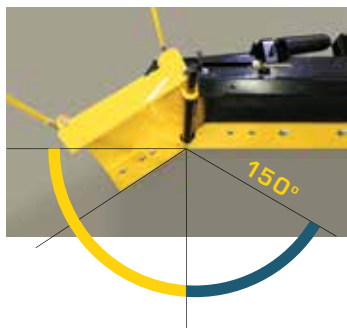

The 29RVHD is designed with patented hydraulic end wings that can be controlled together or independently to move the snow where you want it.

Each wing can be moved from straight out up to a 150° for easier transportation.



Sno-Way's Patented MaxADJUST™ Leveling System allows the user to make adjustments while standing in front of the plow instead of from underneath. The operator can adjust the center hinge for perfect plowing alignment and eliminate a

snow trail. This system allows for easy use on fleets that use more than one type of truck model because there is no plow frame disassembly necessary for proper fit to each truck.

■ **Series 2 Package**

- LED Thermosensitive heated Lights
- Wired ProControl™ 2 Plus ONLY (controls plow & lights)
- Upgraded Hydraulics Package
- Outboard Mount Stand
- Complete Fleet 2-Plug Connection System
- ESS® — Energy Smart System

■ **Patented MaxADJUST™ Leveling System**

■ **Patented Ground Hugger™ Blade Design**

■ **Pre-Drilled Top Blade Rail**

■ **Patented Shock Killer™ Trip Return System**

■ **150° Hydraulic Wing Rotation**

- Infinite Snow Moving Adjustability
- Blade and wings stay parallel to the ground

** Option Up With Smart Sight® and Smart Flash® **

Max Blade Width	10'
Max V Width	114"
Transport Width	102"
Scoop Width	104"
Blade Height (Center/Outer)	29"/36-1/2"
Box Plow Width	96"
Blade Thickness	12 Gauge
Cutting Edge	1/2" x 6"
Vertical Ribs	6
Trip Springs: Extension	2
Plow Shoes	Optional
LED Lights Thermosensitive Heated	Standard
Energy Smart System (ESS®) Technology	Standard
Drive-in Mount System	Standard
Paint: Triple Coat Protection	Standard
Shock Killer™ System	Standard
FlexForce Frame	Standard
Down Pressure® Hydraulic System	Standard
Weight	1,075 lbs.*

* Plow weight does not include weight of vehicle mount

