

SNO-WAY®

SNOW & ICE CONTROL EQUIPMENT

ASSEMBLY & INSTALLATION INSTRUCTIONS

**VEHICLE MOUNT KIT 99101359
AND
VEHICLE CENTER MEMBER 99101139**

**TO FIT
2019 & Later RAM 2500 - 3500 PICKUP**

Sno-Way®; Down Pressure® and EIS® are registered trademarks of Sno-Way International, Inc.
ProControl™, MegaBlade™, V-Wing™, E-Z Switch™, Revolution™, MaxAdjust™, SpeedLock™, and
QuickJack™ are trademarks of Sno-Way International, Inc.

©2019 Sno-Way® International

97102173A



1. **THINK SAFETY, ALWAYS WEAR SAFETY GLASSES WHEN PERFORMING THE OPERATIONS PRESCRIBED IN THESE INSTRUCTIONS**
2. **READ ALL INSTRUCTIONS CAREFULLY BEFORE ATTEMPTING INSTALLATION**
3. **BEFORE BEGINNING WORK MAKE SURE TO SET PARKING BRAKE AND CHOCK WHEELS**



MINIMUM VEHICLE RECOMMENDATIONS

Heavy Duty Alternator
 Heavy Duty Battery
 Manufacturer's Snow Plow Package

ASSEMBLY TOOLS NEEDED

Impact Sockets	7/16" - 1-3/8"
Metric Sockets	10mm - 18mm
Wrenches	7/16" - 1-3/8"
Metric Wrenches	10mm - 18mm
Torque Wrench	
Grinder or Cutting Wheel	
Touch-up Paint	

NOTE: On some vehicles it may be necessary to use a form of load booster to decrease the vehicle's front suspension sag with the snow plow in place. This can be accomplished with the use of supplementary air bags, booster springs, or similar load boosting devices. Since there are different load boosting devices available, it will up to the customer/end user to decide and purchase the product to suit the

INSTALLATION NOTES

1. **Unless otherwise specified, mount all Vehicle Mount Kit Components to vehicle before tightening any hardware.**
2. It is recommended that LOCTITE®, or similar thread locking product, be used on ALL mounting hardware (i.e. Nuts, Cap Screws, Bolts, etc.).
3. Vehicle should be parked on a level surface with a normal vehicle load on the FRONT suspension.
4. Items in parentheses () refer to quantity required for this step. Items in parentheses with a pound sign (#) indicate the part number as found in the parts list on the last page of this document.
 Example: (2) 1/2" Lock Washers (#9).
5. It maybe necessary to relocate license plate holder. Check state and local laws for placement, if needed.

MOUNTING INSTRUCTIONS

1. Remove the lower valance from the bumper.
2. Remove hardware and Frontal Crash Bracket from each side of truck. (See Figure 1.) Keep brackets and hardware for installation on truck if subframe is removed at a later date.

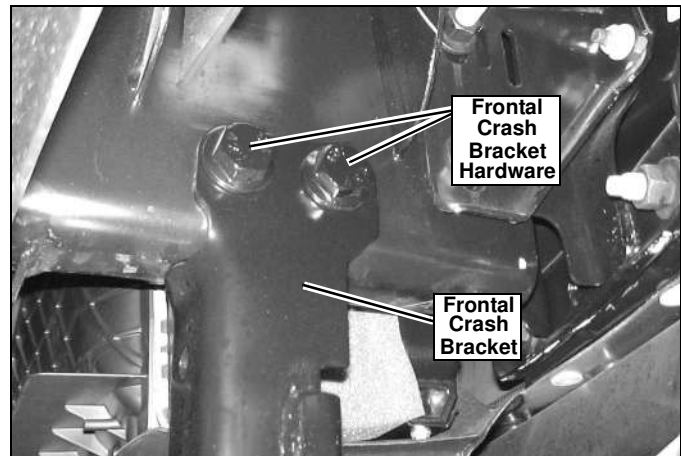

Figure 1

- For the driver and passenger side, loosen the rear tow hook hardware and remove the front. Also, remove the lower bumper bracket hardware. (See Figure 2.) Keep the hardware for installation on truck if subframe is removed.

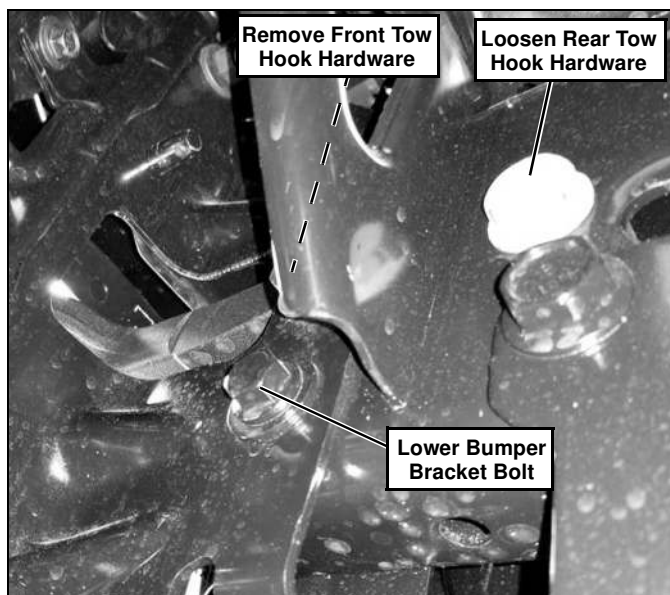

Figure 2

- When the side weldment is fit up to the frame, the lower flange of the bumper bracket will interfere. Cut or grind the inside flange of the bracket for both the driver and passenger sides. (See Figure 3.) Touch up with paint after verifying the cut is sufficient.

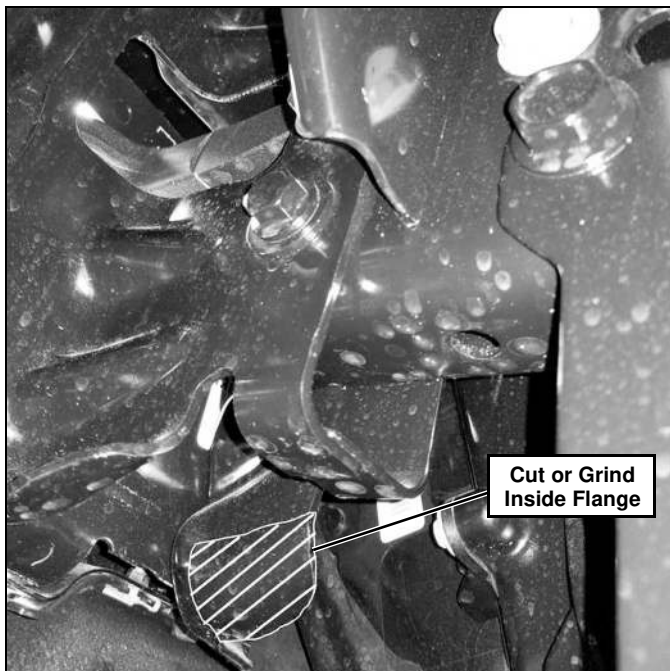

Figure 3

- Place the Driver Side Front Mounting Weldment (#2) against the frame rail and align its 5 holes with the holes in the frame. (See Figure 4.)

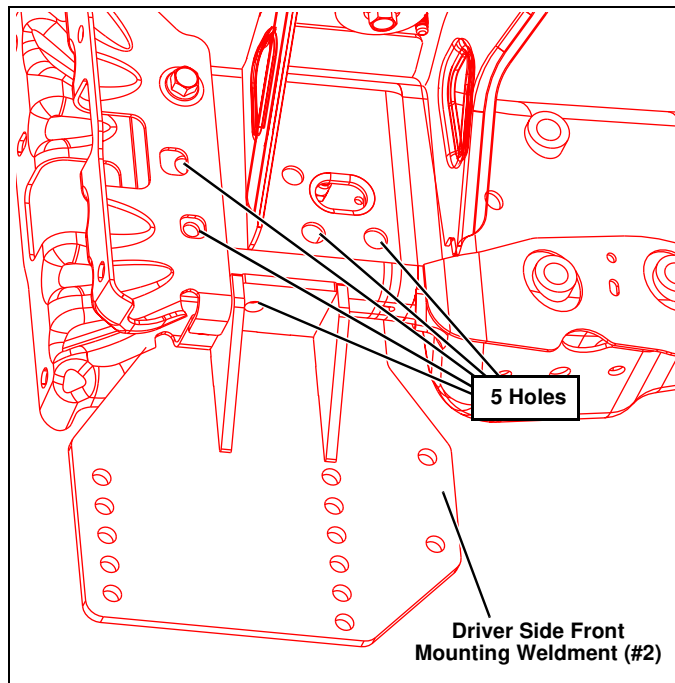

Figure 4

- Insert a 1/2"-13 x 4" Cap Screw (#12) through the lower bumper bracket and secure to the Driver Side Front Mounting Weldment (#2) with a 1/2"-13 Locknut (#13). (See Figure 5.)

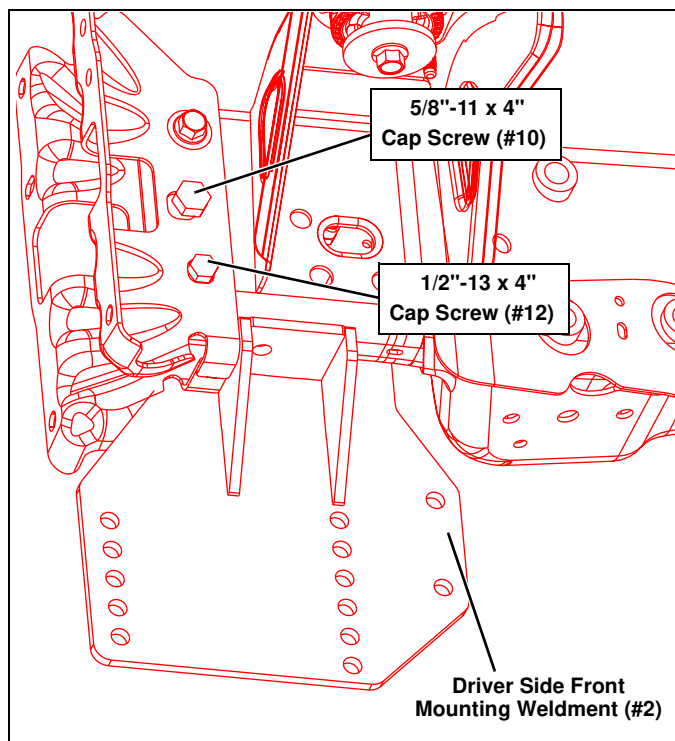

Figure 5

- Insert a 5/8"-11 x 4" Cap Screw (#10) through the frame and front tow hook hole, then secure to the Driver Side Front Mounting Weldment (#2) with a 5/8"-11 Locknut (#11). (See Figure 5.)

- Insert (2) 5/8"-11 x 4" Cap Screws (#10) through the frame where the Frontal Crash Brackets were located and secure to the Driver Side Front Mounting Weldment (#2) with (2) 5/8"-11 Locknuts (#11). (See Figure 6.) If installing on a diesel engine, the intercooler bracket will complicate this step. If there is an intercooler bracket, place the locknuts into position with the open end of a wrench, then insert the cap screw through the frame. You may have to pry the intercooler bracket away from the vehicle frame during this step.

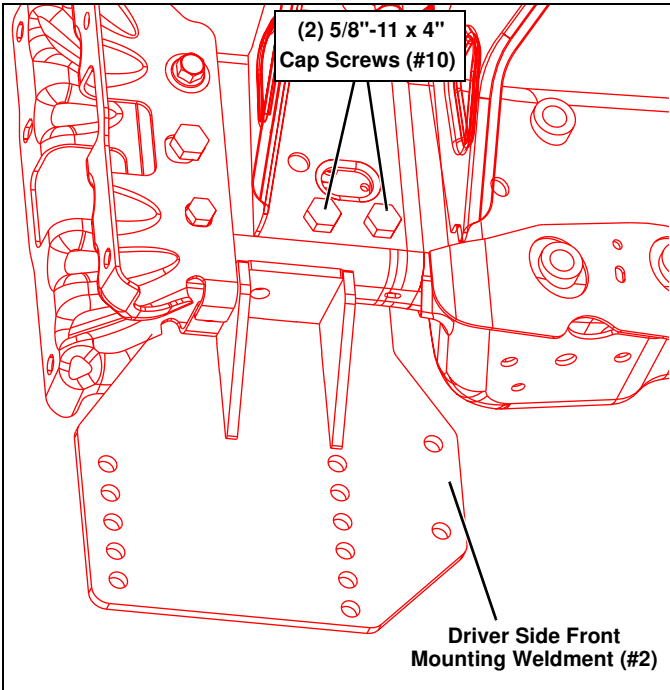

Figure 6

- Insert a 1/2"-13 x 1-1/2" Cap Screw (#16) through a 1/2" Lock Washer (#15), the Driver Side Front Mounting Weldment (#2), and truck frame rail. Secure using a 1/2"-13 Wire Nut (#14). (See Figure 7.)

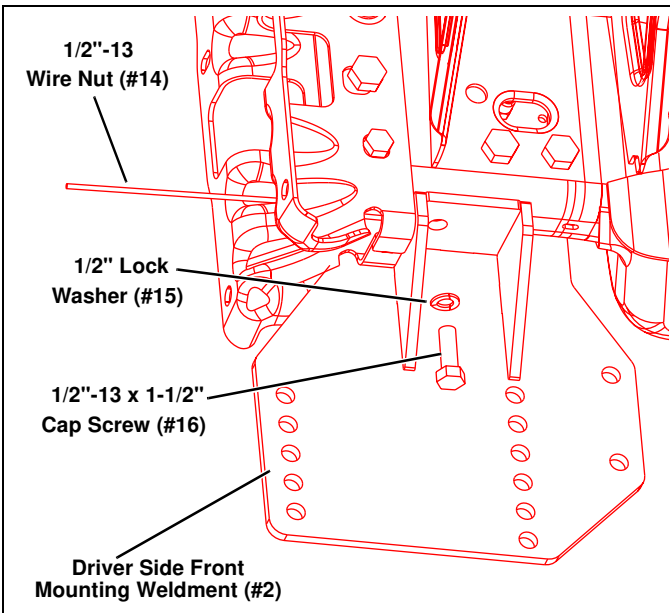

Figure 7

- Install the Passenger Side Front Mounting Weldment (#3) by repeating steps 5-9.
- Install the Vehicle Center Member (#1) between the Driver Side Front Mounting Weldments (#2 and #3) using (8) 1/2"-13 x 1-1/2" Caps Screws (#16), (2) 1/2" Lock Washers (#15), and (6) 1/2"-13 Locknuts (#13). (See Figure 8.)

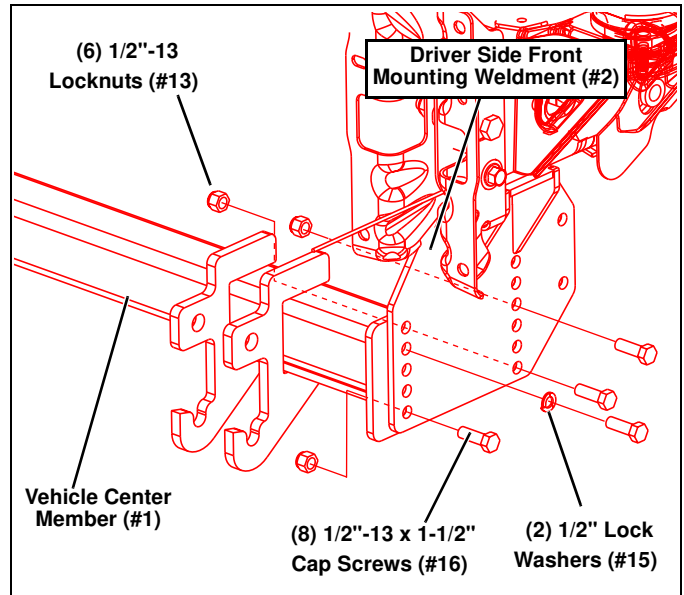

Figure 8

- Remove the hardware attaching the swaybar bushing bracket to the frame.
- Slip the Rear Mounting Weldments, DS (#4) and PS (#5) over the swaybar and swaybar bushing bracket. (See Figure 9.)

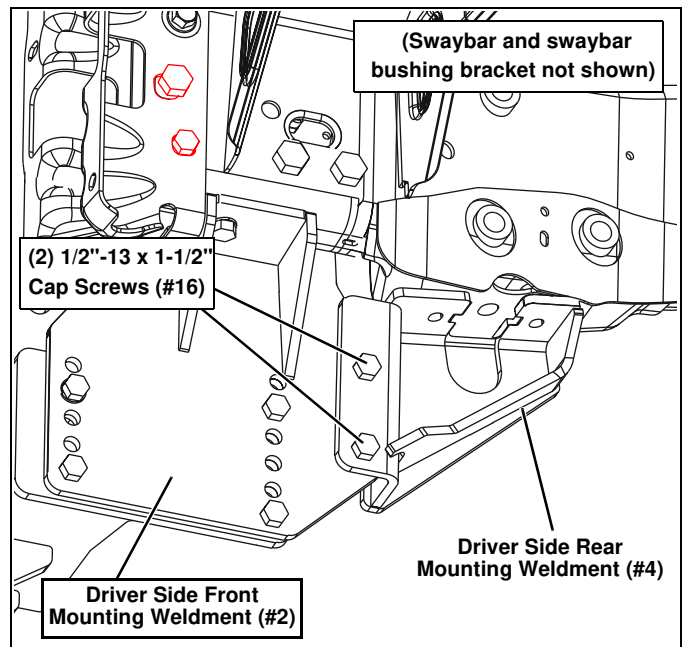

Figure 9

- Assemble the Rear Mounting Weldments onto the Front Mounting Weldments (#2 and #3). Then secure each side using (2) 1/2"-13 x 1-1/2" Cap Screws (#16), and (2) 1/2"-13 Locknuts (#13). (See Figure 9.)

15. Attach the Rear Mounting Weldments to where the swaybar was once attached. Place the Spacer Plate (#6) between the swaybar bushing and the frame rail. Then, loosely secure with (4) 3/8" Flat Washers (#7), (4) M10 Lock Washers (#8), and (4) M10-1.5 x 35 Cap Screws (#9). (See Figure 10.)

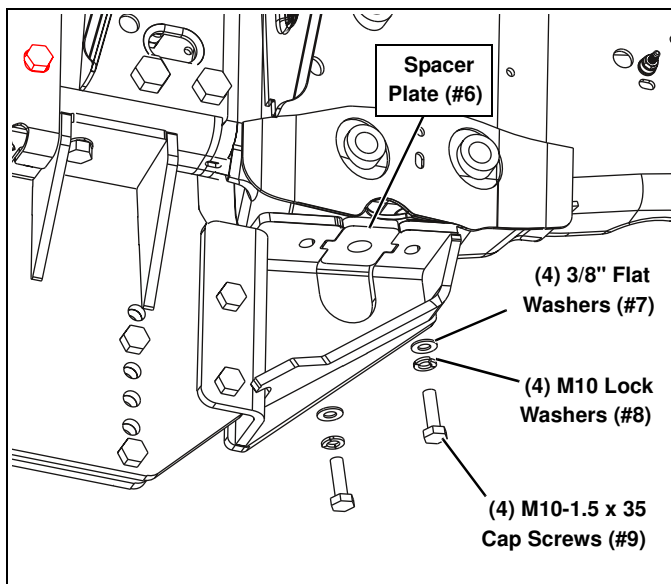
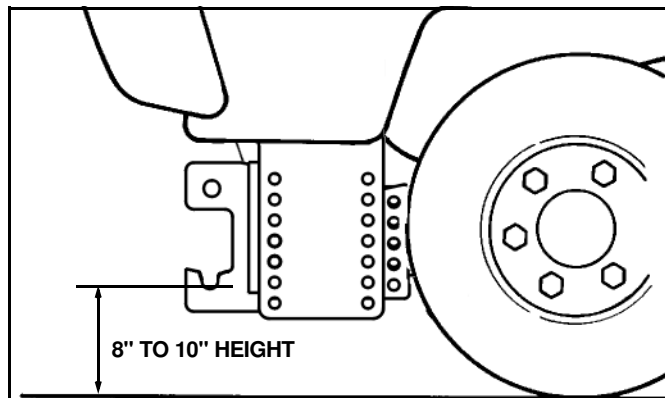

Figure 10

16. With all components in place, tighten all hardware. The mounting hardware for the Front Mounting Weldments should be tightened first then the remaining hardware. **(DO NOT over-tighten the upper mounting hardware for the Rear Mounting Weldments, as over-tightening could crush the frame rails!)**
17. Using the torque specification chart provided, torque all cap screws.

REMEMBER After 5 to 10 hours of snowplow usage, re-torque all Cap Screws!



IMPORTANT: Height from the bottom of the lower pin slots on the Subframe to the ground should be between 8" and 10" to ensure proper operation.

TORQUE SPECIFICATIONS FOR STANDARD MACHINE HARDWARE

Bolt Size	GR.2 Dry	GR.5 Dry	GR.8 Dry	Metric Size	GR.8.8 Dry
1/4"	66*	9	12	M8	17
5/16"	11	17	25	M10	35
3/8"	20	30	45	M12	60
7/16"	32	50	70	M14	95
1/2"	50	75	110	M16	155
9/16"	70	110	150		
5/8"	100	150	220		
3/4"	175	260	380		
7/8"	170	430	600		
1"	250	640	900		

These torque values are to be used for all hardware. Unless otherwise specified, all torque values must meet this specification.

All torque values are in Ft.-Lbs unless otherwise stated

*In-Lbs

PARTS LIST

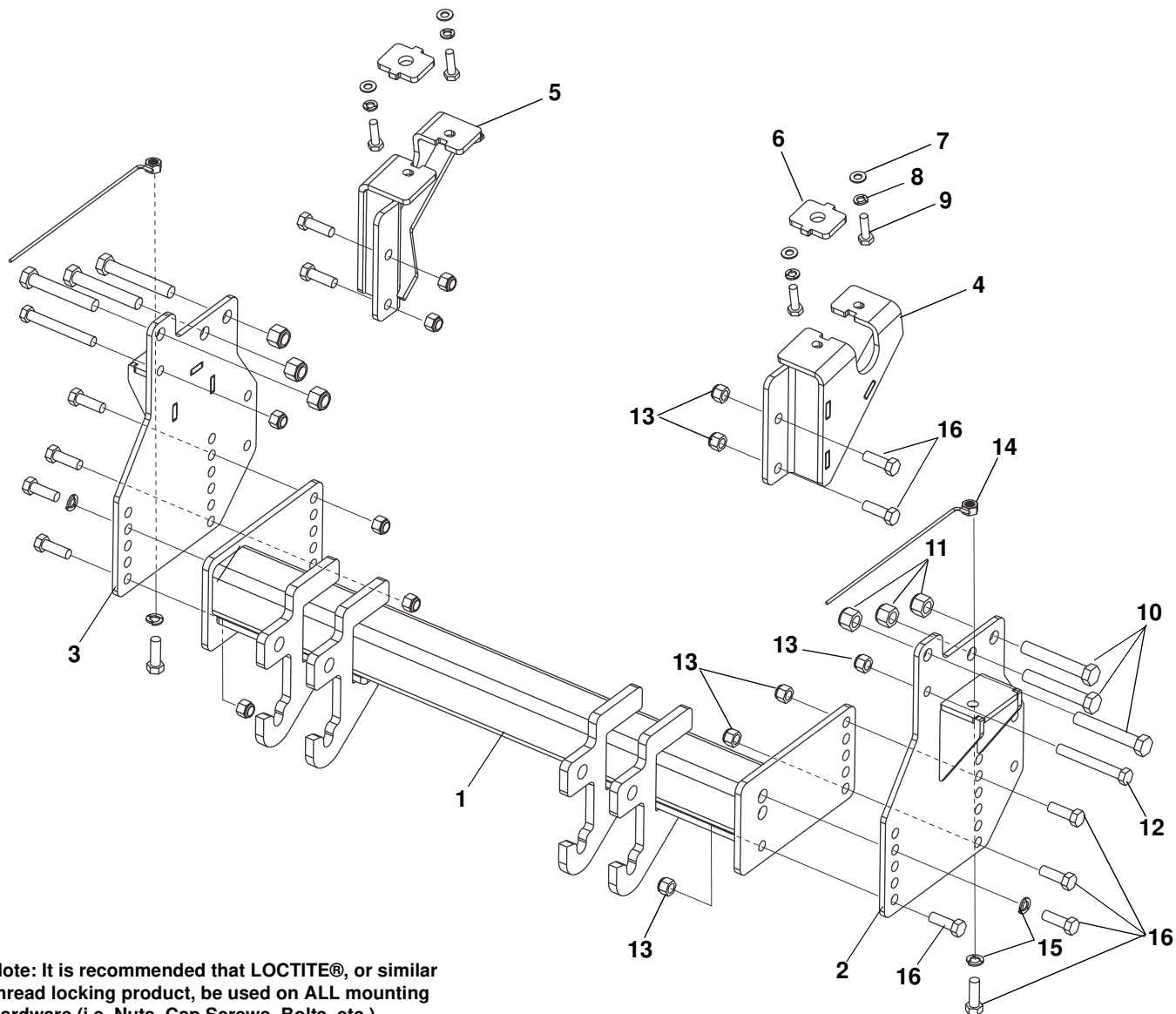

Note: It is recommended that LOCTITE®, or similar thread locking product, be used on ALL mounting hardware (i.e. Nuts, Cap Screws, Bolts, etc.).

ITEM	PART NO.	DESCRIPTION	QTY.
1	99101139	Vehicle Center Member (96114990).....	1
2		Front Mtg Weldment, DS.....	1
3		Front Mtg Weldment, PS.....	1
4		Rear Mtg Weldment, DS.....	1
5		Rear Mtg Weldment, PS.....	1
6		Plate, Spacer.....	2
7		PW, 3/8.....	4
8		LW, M10.....	4
9		HHCS, M10-1.5 x 35.....	4
10		HHCS, 5/8"-11 x 4".....	6
11		LN, 5/8"-11.....	6
12		HHCS, 1/2"-13 x 4".....	2
13		LN, 1/2"-13.....	12
14		Nut Wire Assembly, 1/2"-13.....	2
15		LW, 1/2".....	4
16		HHCS, 1/2"-13 x 1-1/2".....	14
17	96117314	Kit, HDWE (Includes Items 6-16).....	1

NOTES

SNO-WAY® INTERNATIONAL, INC.



Hartford, WI 53027 USA
Website: www.snoway.com
©2019 Sno-Way® International