

SNO-WAY®

SNOW & ICE CONTROL EQUIPMENT

ASSEMBLY & INSTALLATION INSTRUCTIONS

**VEHICLE MOUNT KIT 99101381
FOR UTV SERIES PLOW**

TO FIT
2017 & Later - Cub Cadet Challenger 550 & 750



©2019 Sno-Way® International

97102165A



1. THINK SAFETY, ALWAYS WEAR SAFETY GLASSES WHEN PERFORMING THE OPERATIONS PRESCRIBED IN THESE INSTRUCTIONS
2. READ ALL INSTRUCTIONS CAREFULLY BEFORE ATTEMPTING INSTALLATION
3. BEFORE BEGINNING WORK MAKE SURE TO SET PARKING BRAKE AND CHOCK WHEELS



ASSEMBLY TOOLS NEEDED

Impact Sockets	9/16", 3/4", 15/16", 13 mm-18 mm
Wrenches	9/16", 3/4", 15/16"
Torque Wrench	

INSTALLATION NOTES

1. Vehicle should be parked on a level surface with a normal vehicle load on the FRONT suspension.
2. On some vehicles it may be necessary to raise or stiffen the suspension to decrease the vehicles front suspension sag with the snow plow in place.
3. Unless otherwise specified, mount all Vehicle Mount Kit Components to vehicle before tightening any hardware.
4. It is recommended that LOCTITE®, or similar thread locking product, be used on ALL mounting hardware (i.e. Nuts, Cap Screws, Bolts, etc.).
5. Items in parentheses () refer to quantity required for this step. Items in parentheses with a pound sign (#) indicate the part number as found in the parts list on the last page of this document.
Example: (2) 1/2" Lock Washers (#9).

MOUNTING INSTRUCTIONS

1. Remove the two lower Brush Guard bolts.
(See Figure 1.)

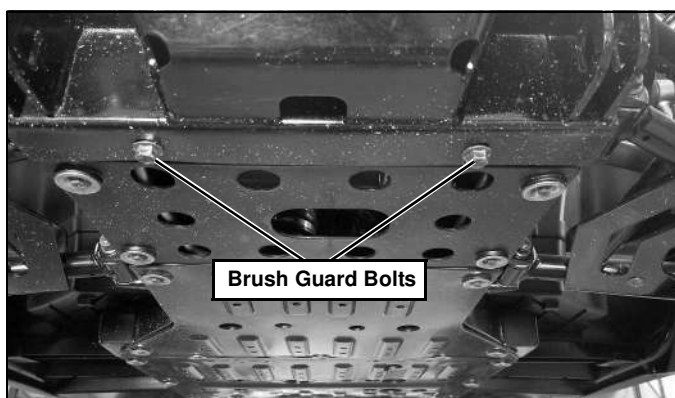

Figure 1

2. Fit up the Mounting Weldment (#2) to the frame. Align the top holes of item #2 with the holes in the receiver hitch of the frame. Fasten with (1) 5/8"-11 x 4" Cap Screw (#4) and (1) 5/8"-11 Locknut (#5).
(See Figure 2.)

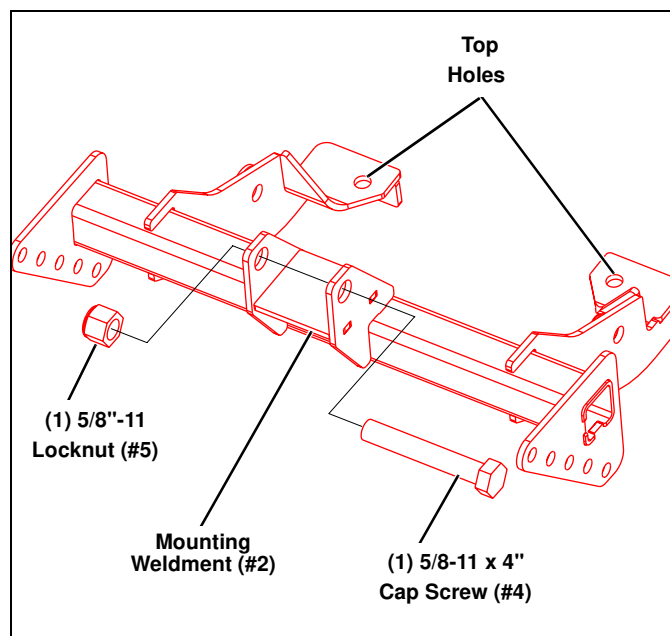

Figure 2

- Align the back holes of the Mounting Weldment (#2) with the holes exposed from step 1. Insert the lower Brush Guard bolts back in place. (See Figure 3.)

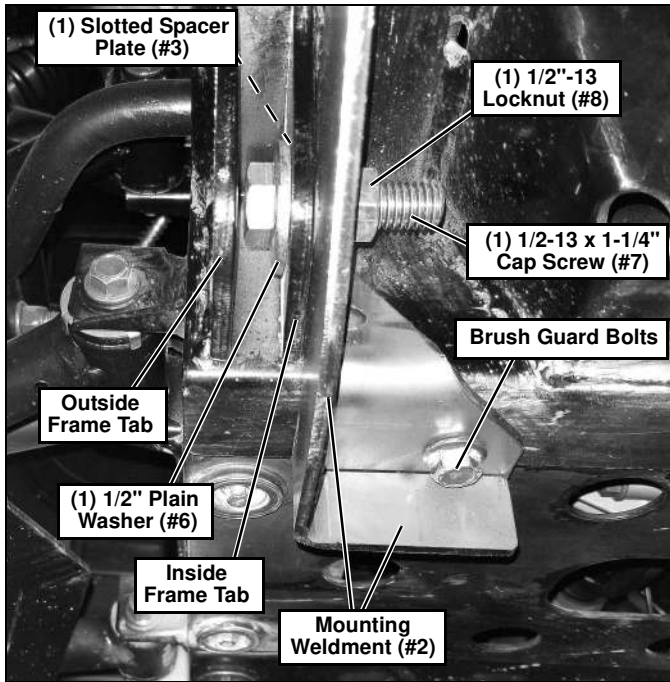

Figure 3 - Passenger Side Shown

- Fit a Slotted Spacer Plate (#3) into the inside Passenger Side frame tab. Insert a 1/2" Plain Washer (#6) between the outside and inside frame tabs to align with the hole of the Slotted Spacer Plate (#3). Insert a 1/2"-13 x 1-1/4" Cap Screw (#7) through the slot of the outside frame tab, then the 1/2" Plain Washer (#6), Slotted Spacer Plate (#3), and Mounting Weldment (#2). Fasten the cap screw with (1) 1/2"-13 Locknut (#8). (See Figure 3 and Figure 4.)

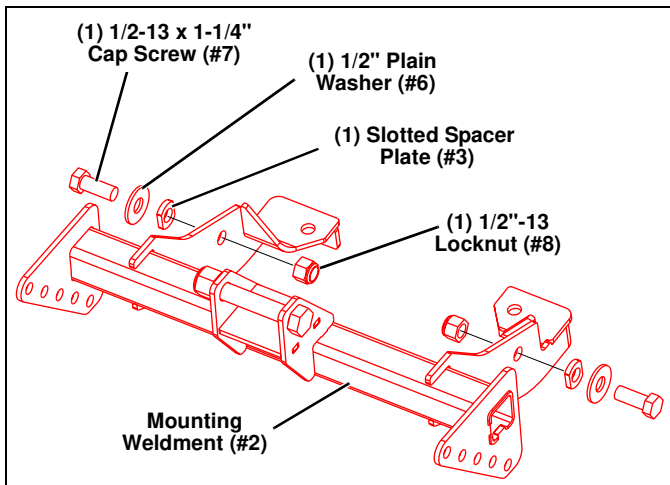

Figure 4

- Repeat step 4 to installing parts on the Driver Side of the Mounting Weldment (#2).

- Attach the UTV Mount (#1) to the Mounting Weldment (#2) with (6) 3/8"-16 x 1" Cap Screws (#3) and (6) 3/8"-16 Locknuts (#4) (three on each side). (See Figure 5.)

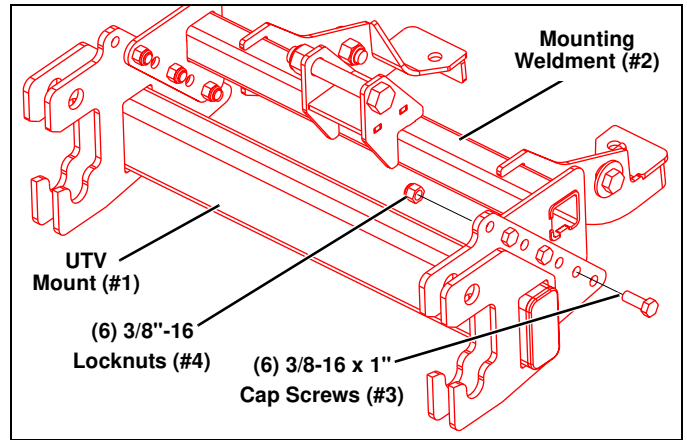

Figure 5

- Adjust the UTV Mount (#1) so that the center of the bottom slot is 11-12" off the ground. (See Figure 6.)

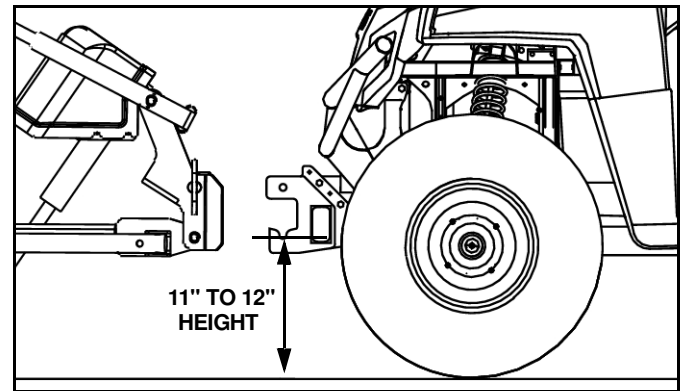

Figure 6

IMPORTANT: Height from the bottom of the lower pin slots on the UTV Mount to the ground should be between 11" and 12" to ensure proper operation.

- Tighten all hardware using the Torque Specification Chart below.

TORQUE SPECIFICATIONS FOR STANDARD MACHINE HARDWARE					
Bolt Size	GR.2 Dry	GR.5 Dry	GR.8 Dry	Metric Size	GR.8.8 Dry
1/4"	66*	9	12	M8	17
5/16"	11	17	25	M10	35
3/8"	20	30	45	M12	60
7/16"	32	50	70	M14	95
1/2"	50	75	110	M16	155
9/16"	70	110	150		
5/8"	100	150	220		
3/4"	175	260	380		
7/8"	170	430	600		
1"	250	640	900		

These torque values are to be used for all hardware. Unless otherwise specified, all torque values must meet this specification.
All torque values are in Ft.-Lbs unless otherwise stated
*In-Lbs

REMEMBER After 5 to 10 hours of snowplow usage, re-torque all hardware!

PARTS LIST

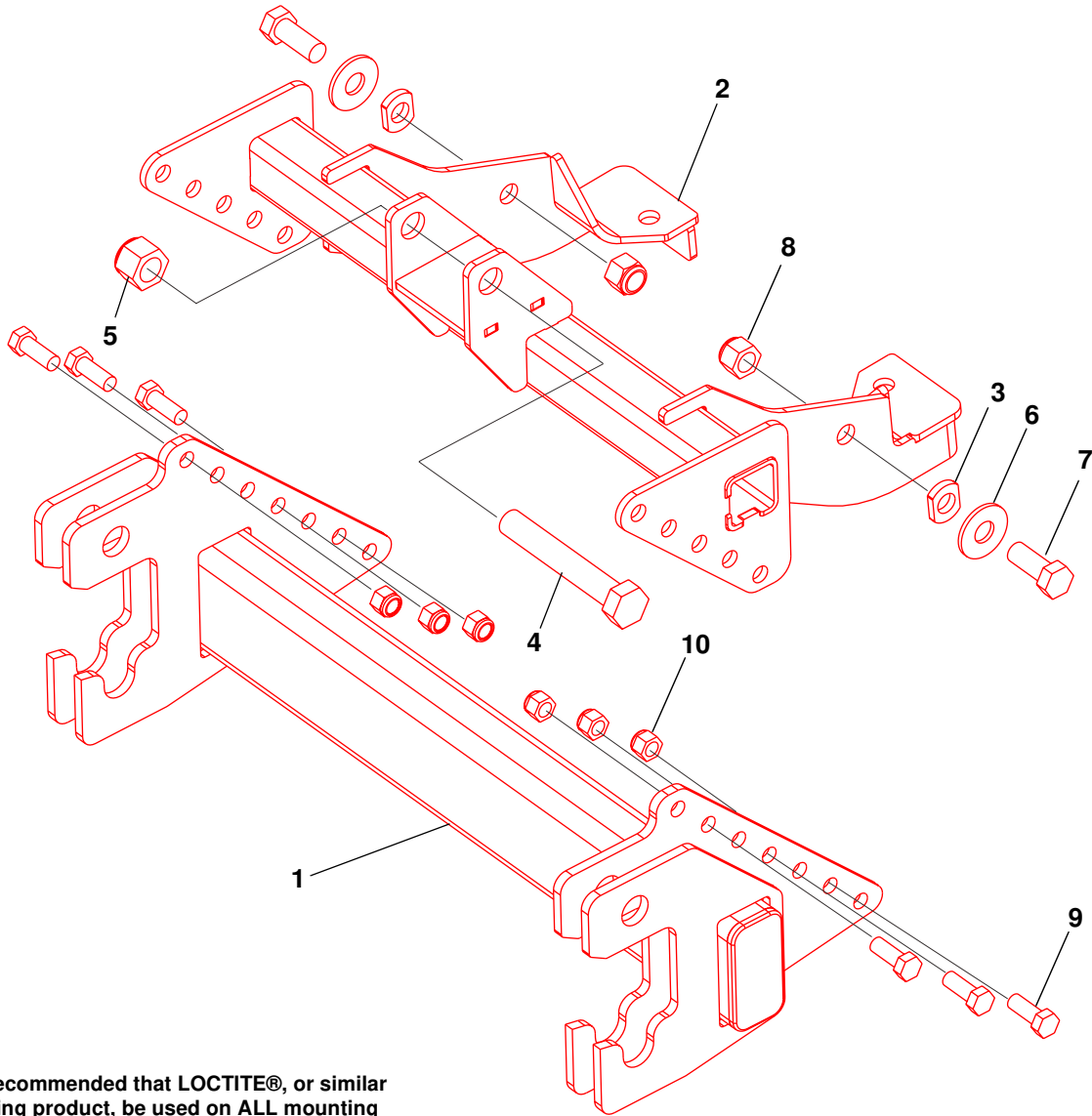

Note: It is recommended that LOCTITE®, or similar thread locking product, be used on ALL mounting hardware (i.e. Nuts, Cap Screws, Bolts, etc.).

ITEM	PART NO.	DESCRIPTION	QTY.
1		UTV Mount.....	1
2		Weldment, Mounting	1
3		Plate, Slotted Spacer	2
4		HHCS, 5/8-11 x 4"	1
5		LN, 5/8"-11	1
6		PW, 1/2"	2
7		HHCS, 1/2-13 x 1-1/4"	2
8		LN, 1/2"-13.....	2
9		HHCS, 3/8-16 x 1"	6
10		LN, 3/8"-16.....	6
11	96117320	Kit, HDWE (Includes items 3-10) (Not Shown)	1

SNO-WAY® INTERNATIONAL, INC.



Hartford, WI 53027 USA
 Website: www.snoway.com
 ©2019 Sno-Way® International