

SNO-WAY®

SNOW & ICE CONTROL EQUIPMENT

ASSEMBLY & INSTALLATION INSTRUCTIONS

**SUBFRAME 99101358
FOR 22 PLOW SERIES ONLY
(Includes Vehicle Center Member)**

**TO FIT
2019 & LATER FORD RANGER**

Sno-Way®; Down Pressure® and EIS® are registered trademarks of Sno-Way International, Inc.
ProControl™, MegaBlade™, V-Wing™, E-Z Switch™, Revolution™, MaxAdjust™, SpeedLock™, and
QuickJack™ are trademarks of Sno-Way International, Inc.

©2019 Sno-Way® International

97102161A



1. THINK SAFETY, ALWAYS WEAR SAFETY GLASSES WHEN PERFORMING THE OPERATIONS PRESCRIBED IN THESE INSTRUCTIONS
2. READ ALL INSTRUCTIONS CAREFULLY BEFORE ATTEMPTING INSTALLATION
3. BEFORE BEGINNING WORK MAKE SURE TO SET PARKING BRAKE AND CHOCK WHEELS



MINIMUM VEHICLE RECOMMENDATIONS

Heavy Duty Alternator
Heavy Duty Battery

NOTE: On some vehicles it may be necessary to use a form of load booster to decrease the vehicle's front suspension sag with the snow plow in place. This can be accomplished with the use of supplementary air bags, booster springs, or similar load boosting devices. Since there are different load boosting devices available, it will up to the customer/end user to decide and purchase the product to suit the application, and not the responsibility of Sno-Way International, Inc.

ASSEMBLY TOOLS NEEDED

Drill Bits	17/32"
Impact Sockets	3/4"
	7mm – 24mm
Wrenches	3/4"
	7mm – 24mm
Torque Wrench	
Rat Tail Pry Bar	
Cut Off Wheel	

INSTALLATION NOTES

1. Unless otherwise specified, mount all Vehicle Mount Kit Components to vehicle before tightening any hardware.
2. It is recommended that LOCTITE®, or similar thread locking product, be used on ALL mounting hardware (i.e. Nuts, Cap Screws, Bolts, etc.).
3. Vehicle should be parked on a level surface with a normal vehicle load on the FRONT suspension.
4. Items in parentheses () refer to quantity required for this step. Items in parentheses with a pound sign (#) indicate the part number as found in the parts list on the last page of this document.
Example: (10) Washer, Lock, 1/2" (#8).
5. It maybe necessary to relocate license plate holder. Check state and local laws for placement, if needed.

MOUNTING INSTRUCTIONS

1. Remove the Splash Guard (See Figure 1), Tow Hook Covers, and Tow Hooks (See Figure 2). Keep the Tow Hook bolts for installing the Subframe. Everything else can be kept for re-installation if Subframe is ever removed.

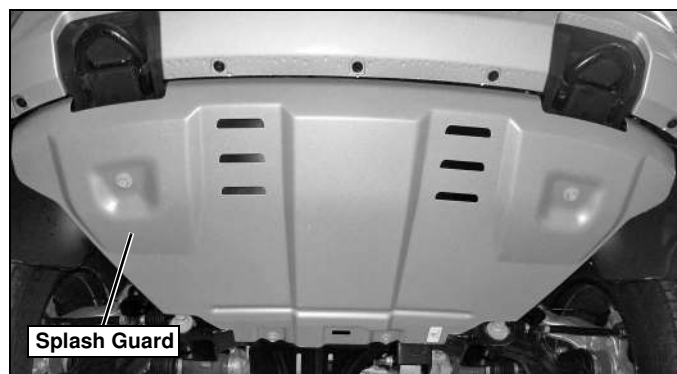

Figure 1

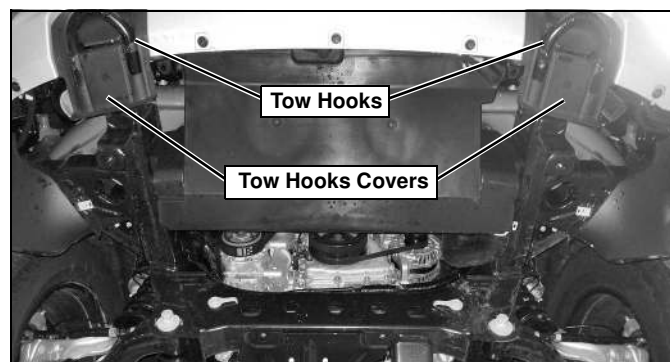

Figure 2

2. Drill the two outside holes on each frame rail (Driver & Passenger Side) to 17/32". (See Figure 3.)



Figure 3

3. Attach the Driver & Passenger Side Mount Weldments (#2 & 3) to the frame. Insert the Tow Hook Bolts into the Mount Weldments (#2 & 3) and back into the bottom of the frame. Feed (2) 1/2"-13 x 1-1/4" Handle Bolt Weldments (#4) into the front of the frame and out the previously drilled holes. Fasten the Handle Bolts with (2) 1/2"-13 Locknuts (#5). Cut off any excess handle sticking out of the frame rail. (See Figure 4.)

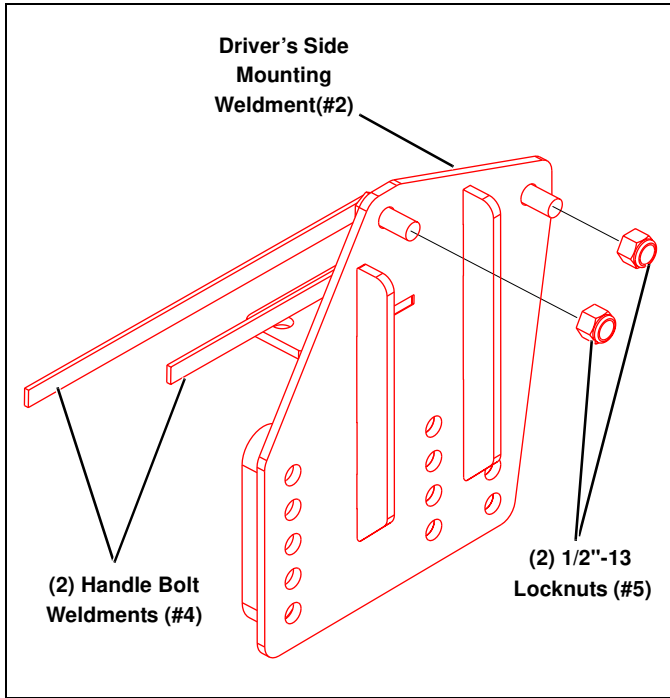

Figure 4

4. Position the Vehicle Center Member (#1) between the Side Mount Weldments (#2 and #3) to allow for an 8" to 10" height between the VCM and the ground. (See Figure 5.)

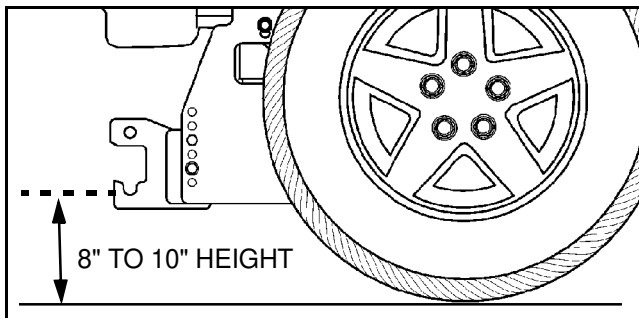

Figure 5

IMPORTANT: Height from the center of the lower Plow Mounting slots on the Vehicle Center Member to the ground should be between 8" and 10" to ensure proper operation.

5. Secure the Vehicle Center Member (#1) using (4) 3/8" Spacer Plates (#6), (8) 1/2"-13 x 2-1/2" Caps Screws (#8), (2) 1/2" Lock Washers (#7) and (6) 1/2"-13 Locknuts (#5). (See Figure 6.)

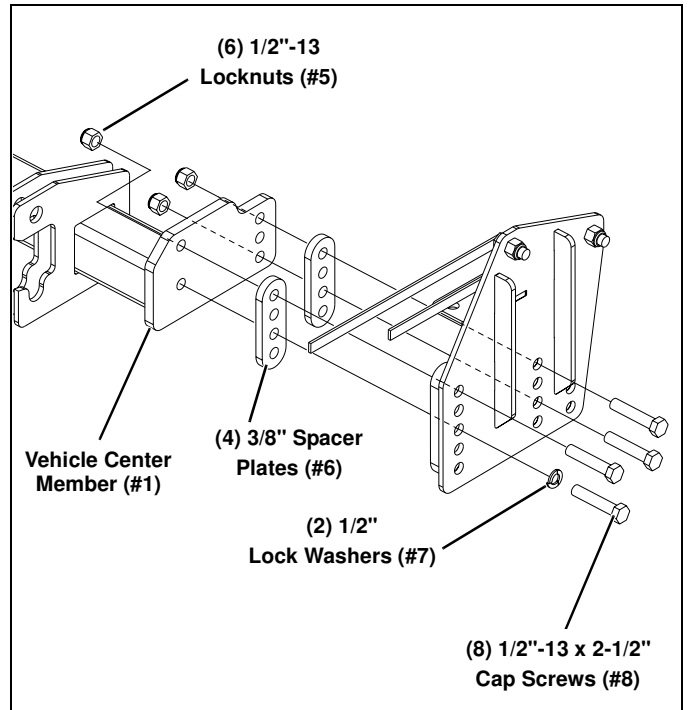

Figure 6

6. Tighten all hardware using the torque specification chart provided below.

TORQUE SPECIFICATIONS FOR STANDARD MACHINE HARDWARE					
Bolt Size	GR.2 Dry	GR.5 Dry	GR.8 Dry	Metric Size	GR.8.8 Dry
1/4"	66*	9	12	M8	17
5/16"	11	17	25	M10	35
3/8"	20	30	45	M12	60
7/16"	32	50	70	M14	95
1/2"	50	75	110	M16	155
9/16"	70	110	150		
5/8"	100	150	220		
3/4"	175	260	380		
7/8"	170	430	600		
1"	250	640	900		

Note: These torque values are to be used for all hardware. Unless otherwise specified, all torque values must meet this specification.
 Note: All torque values are in Ft.-Lbs unless otherwise stated
 Note: *In-Lbs

REMEMBER After 5 to 10 hours of snowplow usage, re-torque all Cap Screws!

PARTS LIST

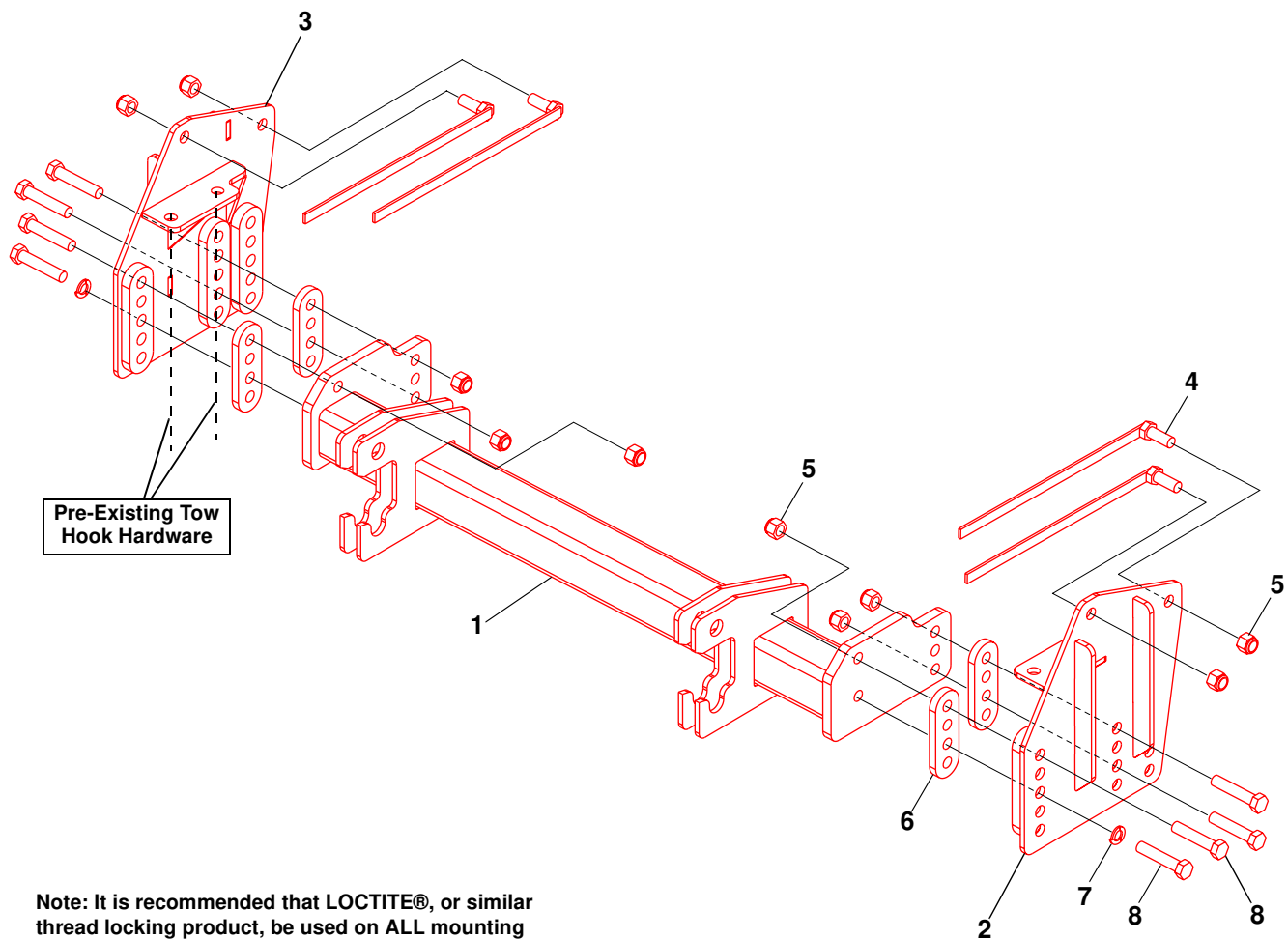

Note: It is recommended that LOCTITE®, or similar thread locking product, be used on ALL mounting hardware (i.e. Nuts, Cap Screws, Bolts, etc.).

ITEM	PART NO.	DESCRIPTION	QTY.
1		Vehicle Center Member	1
2		Weldment, Mount, DS	1
3		Weldment, Mount, PS.....	1
4		Weldment, Handle Bolt, 1/2"-13 x 1-1/4"	4
5		LN, 1/2"-13.....	10
6		Plate, Spacer, 3/8"	4
7		LW, 1/2"	2
8		HHCS, 1/2"-13 x 2-1/2"	8
9	96117372	Kit, HDWE (Includes Items 4-8) (Not Shown)	1

SNO-WAY® INTERNATIONAL, INC.



Hartford, WI 53027 USA
Website: www.snoway.com
©2019 Sno-Way® International