

SNO-WAY®

SNOW & ICE CONTROL EQUIPMENT

ASSEMBLY & INSTALLATION INSTRUCTIONS

VEHICLE MOUNT KIT 99101312

TO FIT
2014 - LATER Honda Pioneer 700

Sno-Way®; Down Pressure® and EIS® are registered trademarks of Sno-Way International, Inc.
ProControl™, MegaBlade™, V-Wing™, E-Z Switch™, Revolution™, MaxAdjust™, SpeedLock™, and
QuickJack™ are trademarks of Sno-Way International, Inc.

©2017 Sno-Way® International

97102113A



1. THINK SAFETY, ALWAYS WEAR SAFETY GLASSES WHEN PERFORMING THE OPERATIONS PRESCRIBED IN THESE INSTRUCTIONS
2. READ ALL INSTRUCTIONS CAREFULLY BEFORE ATTEMPTING INSTALLATION
3. BEFORE BEGINNING WORK MAKE SURE TO SET PARKING BRAKE AND CHOCK WHEELS



ASSEMBLY TOOLS NEEDED

Impact Sockets	7/16" - 3/4"
Impact Sockets	5 mm - 16 mm
Wrenches	5 mm - 16 mm
Wrenches	7/16" - 3/4"
Torque Wrench	
Tape Measure	

INSTALLATION NOTES

1. Vehicle should be parked on a level surface with a normal vehicle load on the FRONT suspension.
2. On some vehicles it may be necessary to raise or stiffen the suspension to decrease the vehicles front suspension sag with the snow plow in place.
3. Unless otherwise specified, mount all Vehicle Mount Kit Components to vehicle before tightening any hardware.
4. It is recommended that LOCTITE®, or similar thread locking product, be used on ALL mounting hardware (i.e. Nuts, Cap Screws, Bolts, etc.).
5. Items in parentheses () refer to quantity required for this step. Items in parentheses with a pound sign (#) indicate the part number as found in the parts list on the last page of this document.
Example: (2) 1/2" Lock Washers (#9).

MOUNTING INSTRUCTIONS

1. Remove the (2) lower Cap Screws (one on each side) holding the brush guard to the frame. (See Figure 1.)

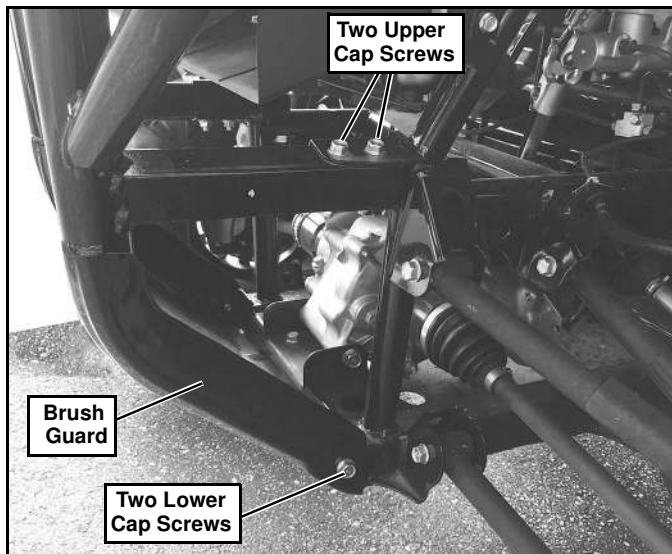

Figure 1

2. Align the rear side holes of the Lower Weldment (#2) with the holes in the brush guard where the hardware was removed in step 1. The bottom holes in the Lower Weldment (#2) will align with holes in the bottom of the frame. (See Figure 2.)

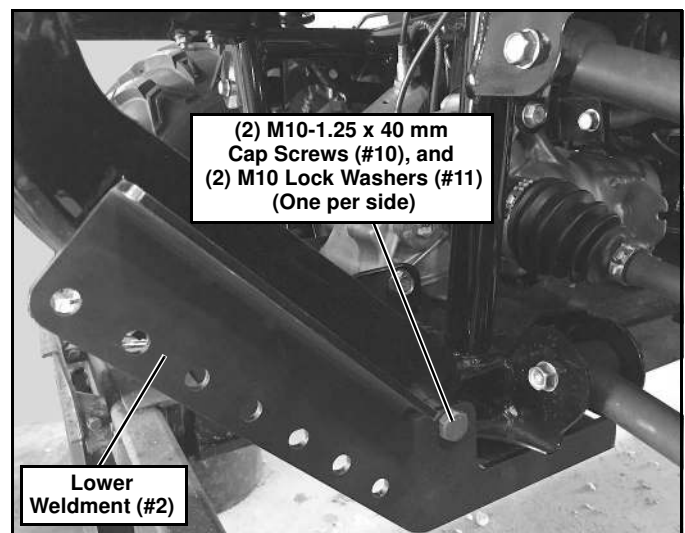

Figure 2

3. Insert (2) M10-1.25 x 40 mm Cap Screws (#10) through (2) M10 Lock Washers (#11), the Lower Weldment (#2), the brush guard, and into the frame. (See Figure 2.)

4. Insert (2) 3/8"-16 x 1-1/2" Cap Screws (#6) through the bottom holes in the Lower Weldment (#2) and into the frame. Secure with (2) 3/8"-16 Lock Nuts (#7). (See Figure 3.)

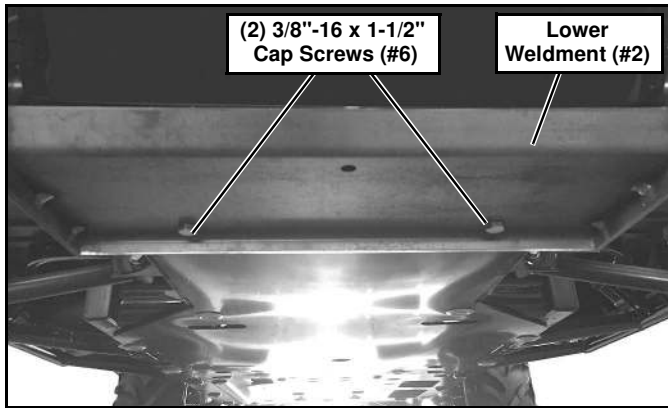

Figure 3

5. On the drivers' side remove the upper (2) Cap Screws holding the brush guard to the frame. (See Figure 1.)
 6. Place the U-shaped section of the Top Driver's Side Weldment (#3) over the frame where the brush guard is connected. The holes in the top of the Top Driver's Side Weldment (#3) align with the holes where the hardware was removed in step 5. (See Figure 4.)

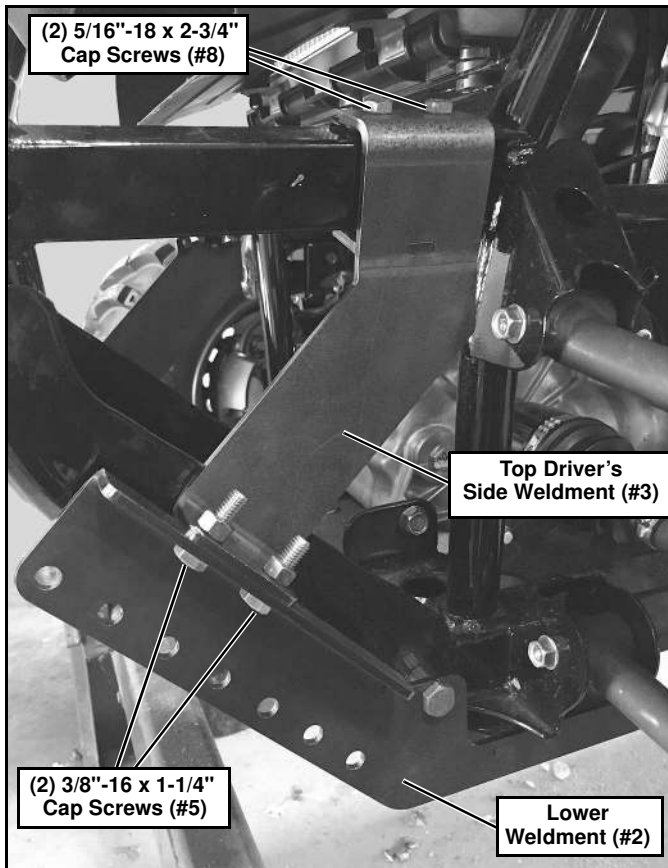

Figure 4

7. Insert (2) 5/16"-18 x 2-3/4" Cap Screws (#8) through the top holes of the Top Driver's Side Weldment, frame, and brush guard. Secure with (2) 5/16"-18 Lock Nuts (#9). (See Figure 4.)

8. Insert (2) 3/8"-16 x 1-1/4" Cap Screws (#5) through the top holes in the Lower Weldment (#2) and into the bottom holes of the Top Driver's Side Weldment (#3). Secure with (2) 3/8"-18 Lock Nuts (#7). (See Figure 4.)

9. Repeat Steps 5-8 on the passengers' side using the Passenger's Side Top Weldment (#4).

10. Position the UTV Mount (#1) on the machine. The UTV Mount (#1) goes to the outside of the Lower Weldment (#2). (See Figure 5.)

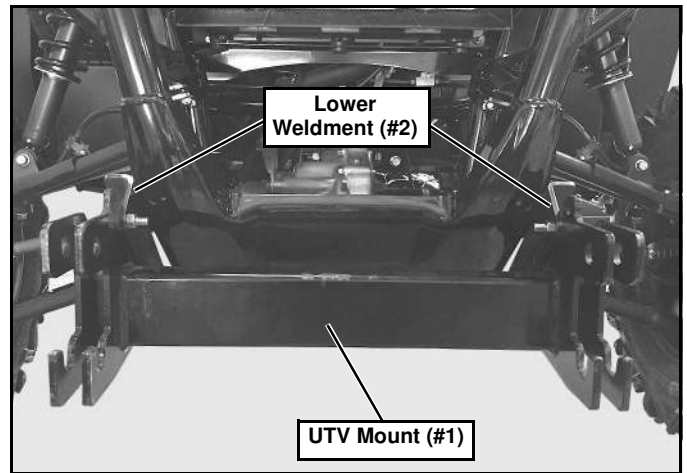

Figure 5

11. Adjust the UTV Mount (#1) on the machine to provide an 11" to 12" height between the lower pin slots and the ground. (See Figure 6.)

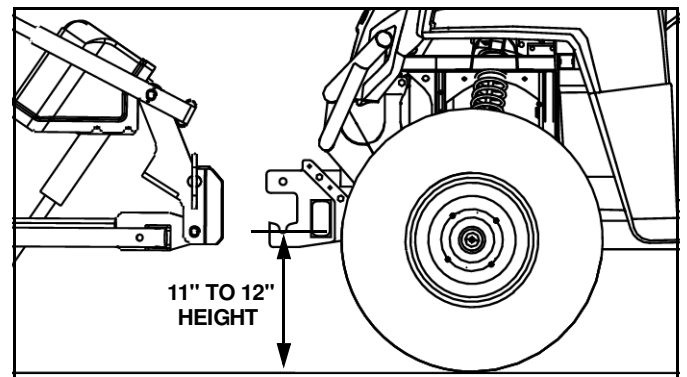

Figure 6

IMPORTANT: Height from the bottom of the lower pin slots on the UTV Mount to the ground should be between 11" and 12" to ensure proper operation.

12. Secure UTV Mount (#1) with (6) 3/8"-16 x 1 1/4" Cap Screws (#5) and (6) 3/8"-16 Lock Nuts (#7).
(See Figure 7.)

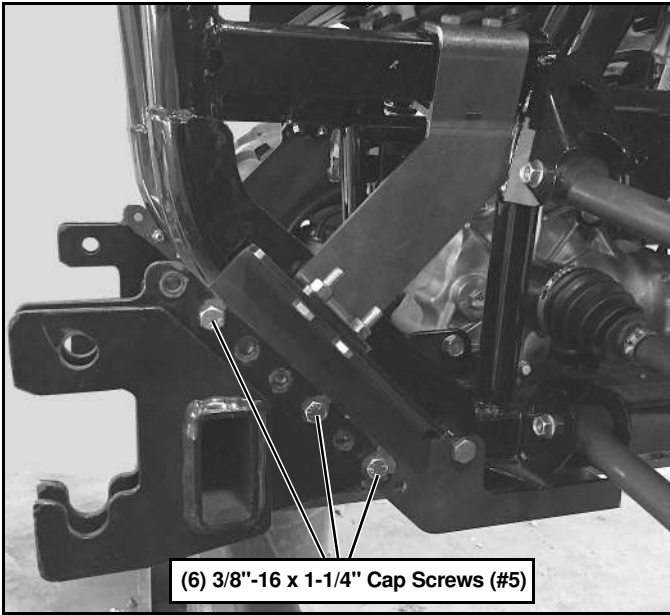

Figure 7

13. Tighten all hardware using the Torque Specification Chart provided.

TORQUE SPECIFICATIONS FOR STANDARD MACHINE HARDWARE					
Bolt Size	GR.2 Dry	GR.5 Dry	GR.8 Dry	Metric Size	GR.8.8 Dry
1/4"	66*	9	12	M8	17
5/16"	11	17	25	M10	35
3/8"	20	30	45	M12	60
7/16"	32	50	70	M14	95
1/2"	50	75	110	M16	155
9/16"	70	110	150		
5/8"	100	150	220		
3/4"	175	260	380		
7/8"	170	430	600		
1"	250	640	900		

Note: These torque values are to be used for all hardware. Unless otherwise specified, all torque values must meet this specification.
Note: All torque values are in Ft.-Lbs unless otherwise stated
Note: *In-Lbs

NOTE: After 5 to 10 hours of snowplow usage, re-torque all Cap Screws!

PARTS LIST

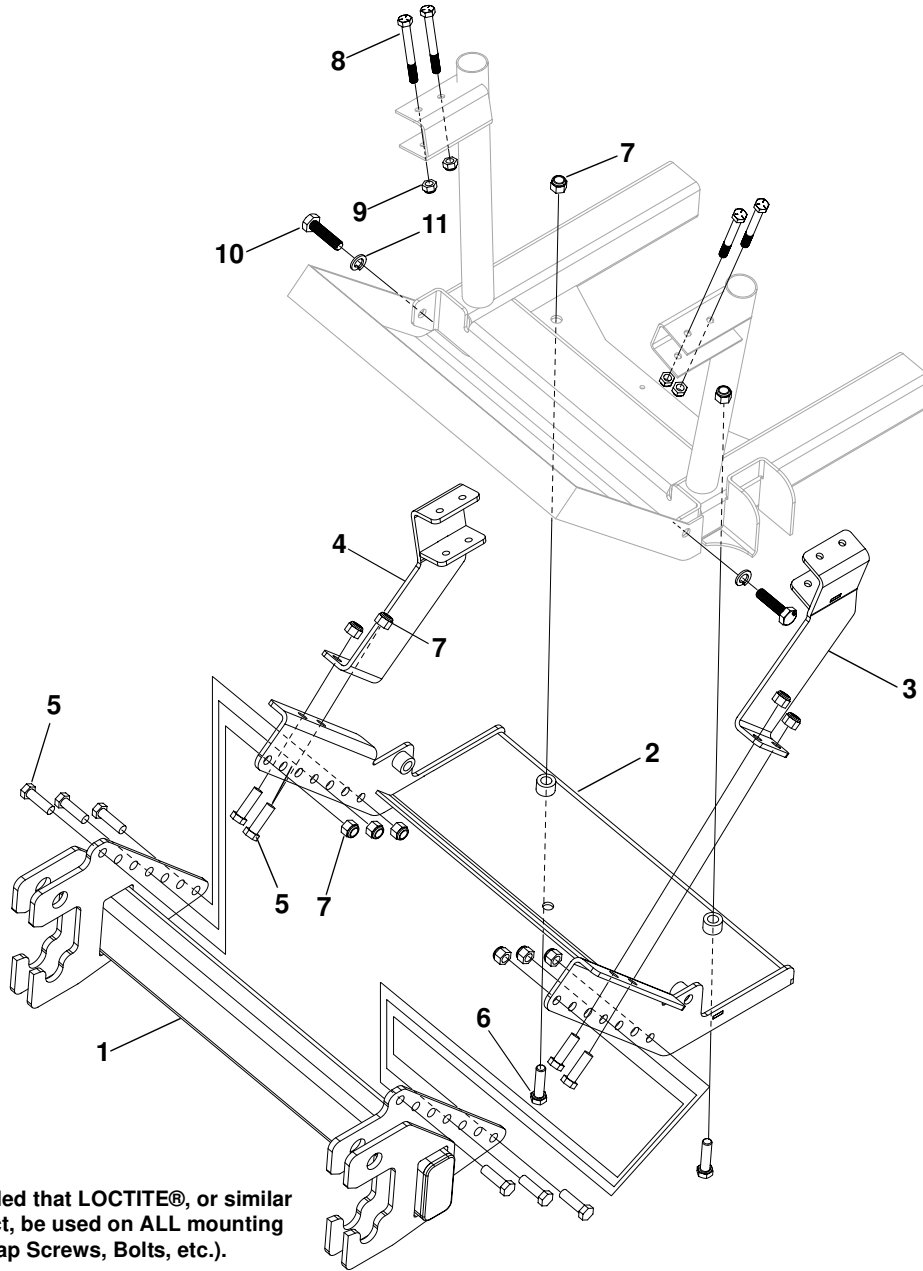

Note: It is recommended that LOCTITE®, or similar thread locking product, be used on ALL mounting hardware (i.e. Nuts, Cap Screws, Bolts, etc.).

ITEM	PART NO.	DESCRIPTION	QTY.
1		UTV Mount	1
2		Weldment, Lower.....	1
3		Weldment, Front, Driver's Side.....	1
4		Weldment, Front, Passenger's Side.....	1
5		HHCS, 3/8"-16 x 1-1/4".....	10
6		HHCS, 3/8"-16 x 1-1/2".....	2
7		LN, 3/8"-16	12
8		HHCS, 5/16"-18 x 2-3/4".....	4
9		LN, 5/16"-18	4
10		HHCS, M10-1.25 x 40 mm	2
11		LW, M10.....	2
12	96116716	Kit, HDWE (1312) (Includes items 5-11) (Not Shown).....	1

NOTES

NOTES

SNO-WAY® INTERNATIONAL, INC.



Hartford, WI 53027 USA
Website: www.snoway.com
©2017 Sno-Way® International