

SNO-WAY®

SNOW & ICE CONTROL EQUIPMENT

ASSEMBLY & INSTALLATION INSTRUCTIONS

VEHICLE MOUNT KIT 99101304

TO FIT
2015 - LATER BOBCAT 3400

Sno-Way®; Down Pressure® and EIS® are registered trademarks of Sno-Way International, Inc.
ProControl™, MegaBlade™, V-Wing™, E-Z Switch™, Revolution™, MaxAdjust™, SpeedLock™, and
QuickJack™ are trademarks of Sno-Way International, Inc.

©2017 Sno-Way® International

97102103A



1. THINK SAFETY, ALWAYS WEAR SAFETY GLASSES WHEN PERFORMING THE OPERATIONS PRESCRIBED IN THESE INSTRUCTIONS
2. READ ALL INSTRUCTIONS CAREFULLY BEFORE ATTEMPTING INSTALLATION
3. BEFORE BEGINNING WORK MAKE SURE TO SET PARKING BRAKE AND CHOCK WHEELS



ASSEMBLY TOOLS NEEDED

Impact Sockets	7/16" - 3/4"
Impact Sockets	5 mm - 16 mm
Wrenches	5 mm - 16 mm
Wrenches	7/16" - 3/4"
Torque Wrench	
Cutting Wheel	
Tape Measure	

INSTALLATION NOTES

1. Vehicle should be parked on a level surface with a normal vehicle load on the FRONT suspension.
2. On some vehicles it may be necessary to raise or stiffen the suspension to decrease the vehicles front suspension sag with the snow plow in place.
3. Unless otherwise specified, mount all Vehicle Mount Kit Components to vehicle before tightening any hardware.
4. It is recommended that LOCTITE®, or similar thread locking product, be used on ALL mounting hardware (i.e. Nuts, Cap Screws, Bolts, etc.).
5. Items in parentheses () refer to quantity required for this step. Items in parentheses with a pound sign (#) indicate the part number as found in the parts list on the last page of this document.
Example: (2) 1/2" Lock Washers (#9).

MOUNTING INSTRUCTIONS

1. Remove brush guard, if installed.
Brush guard is held in place by (4) Cap Screws:
 - (2) located in the inside lower area (See Figure 1), and
 - (2) in the middle outside. (See Figure 2.)

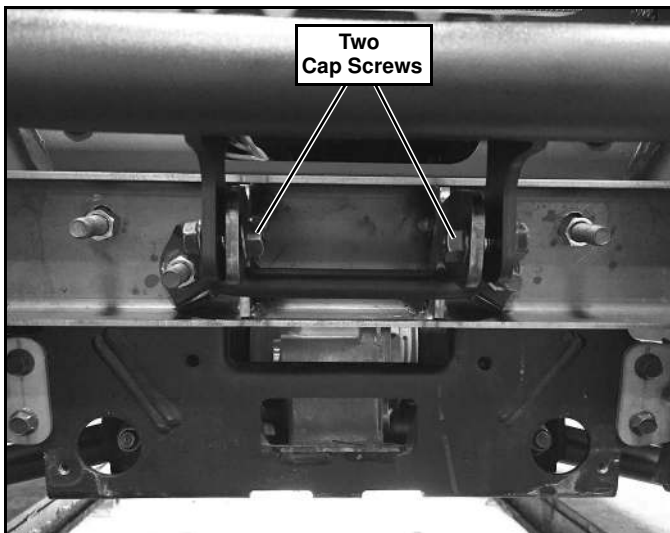

Figure 1



Figure 2

- Remove lower grill by removing (2) lower cap screws and snapping grill out. (See Figure 3.)



Figure 3

- Remove tow hook and brush guard brackets, if equipped (brush guard brackets not shown in images). (See Figure 4.)

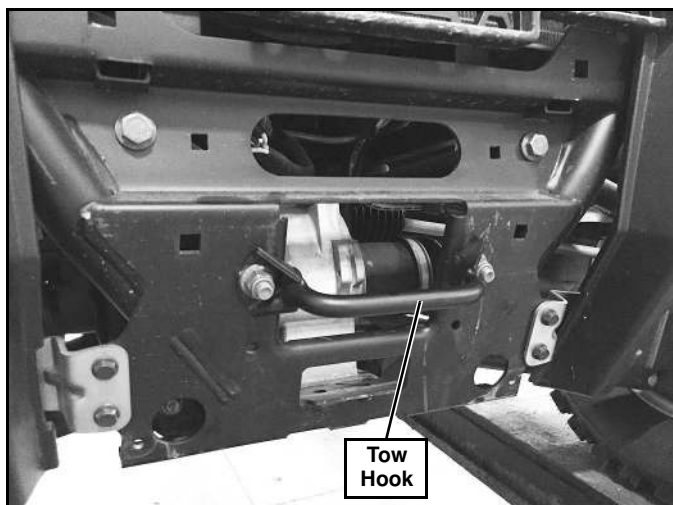

Figure 4

- Align the slots in the Top Weldment (#3) with the (4) square holes in the vehicle frame. The lower slots in the Top Weldment (#3) align with the holes that the tow hook was attached too. Place the tow hook over top of the Top Weldment (#3) aligned with the lower slots. (See Figure 5.)

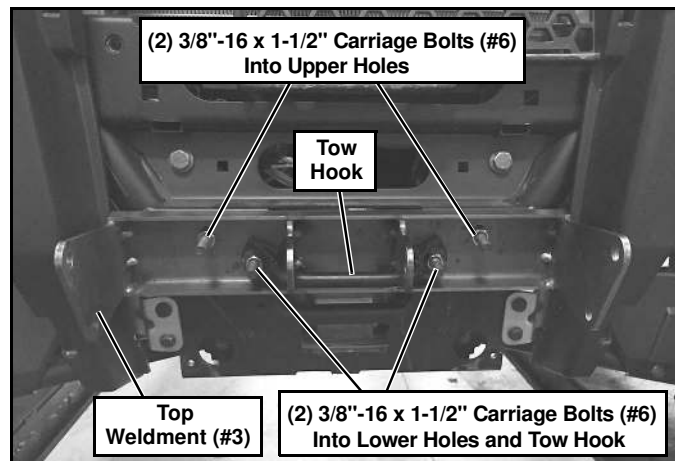

Figure 5

- Insert (2) 3/8"-16 x 1-1/2" Carriage Bolts (#6) into the upper square holes in the vehicle frame and through the Top Weldment (#3). Secure with (2) 3/8" Flat Washers (#10) and (2) 3/8"-16 Lock Nuts (#9). Insert (2) 3/8"-16 x 1-1/2" Carriage Bolts (#6) into the lower square holes in the vehicle frame, through the Top Weldment (#3), and through the tow hook. Secure with (2) 3/8" Flat Washers (#10) and (2) 3/8"-16 Lock Nuts (#9). (See Figure 5.)
- Tighten Hardware installed in step 5.
- Trim lower grill to fit around Top Weldment (#3) and reinstall.
- Align the 4 holes in the Bottom Weldment (#2) with the 4 holes in the bottom of the frame. Align (2) Spacers (#11) with the rear holes and insert between the Bottom Weldment (#2) and frame. (See Figure 6.)

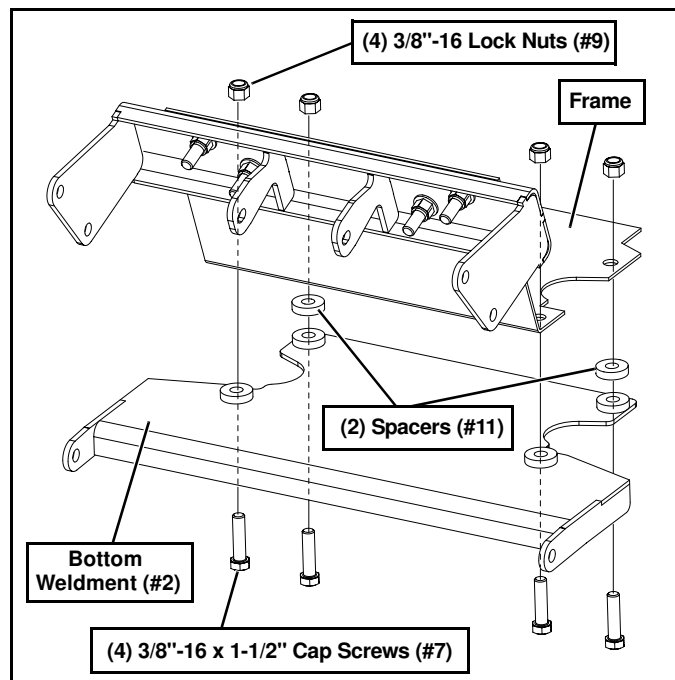

Figure 6

- Insert (4) 3/8"-16 x 1-1/2" Cap Screws (#7) into the Bottom Weldment (#2) and through the frame. Secure with (4) 3/8"-16 Lock Nuts (#9). (See Figure 6.)

10. Attach the brush guard using original hardware, if installed.

NOTE: The (2) cap screws located in the inside lower area of the brush guard will now be attached to the Top Weldment (#3).

11. On the driver's side, align the Driver's Side Front Bracket (#4) to the outside of the Top Weldment (#3) and Bottom Weldment (#2). The rearward (2) holes align with the Top Weldment (#3), and the forward bottom hole aligns with the hole in the Bottom Weldment (#2). (See Figure 7.)

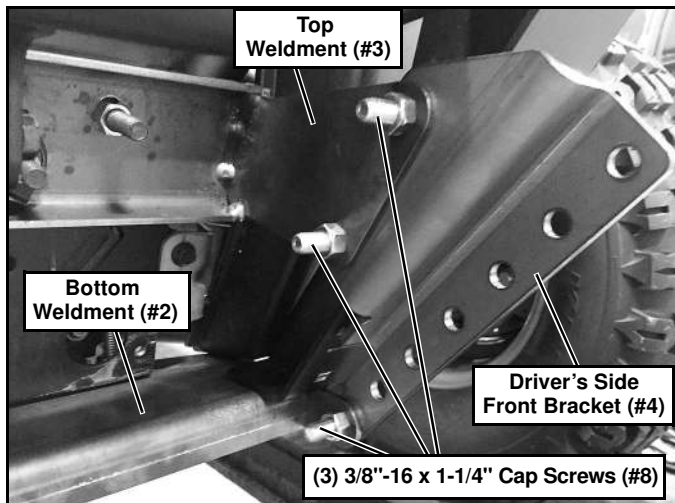

Figure 7

12. Insert (3) 3/8"-16 x 1-1/4" Cap Screws (#8) into the Driver's Side Front Bracket (#4), and through the Top and Bottom Weldments (#3 and #2). Secure with (3) 3/8"-16 Lock Nuts (#9). (See Figure 7.)

13. Repeat Steps 11 and 12 on the passenger's side using the Passenger's Side Front Bracket (#5).

14. Position the UTV Mount (#1) on the machine. The UTV Mount (#1) goes to the outside of the Driver and Passenger Side Top Brackets (#4 and #5). (See Figure 8.)

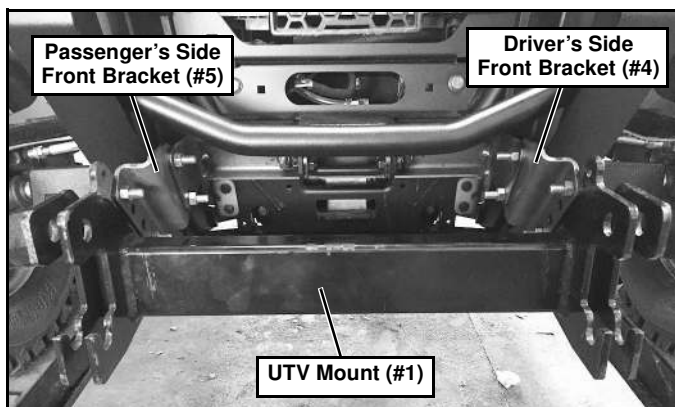

Figure 8

15. Adjust the UTV Mount (#1) on the machine to provide an 11" to 12" height between the lower pin slots and the ground. (See Figure 9.)

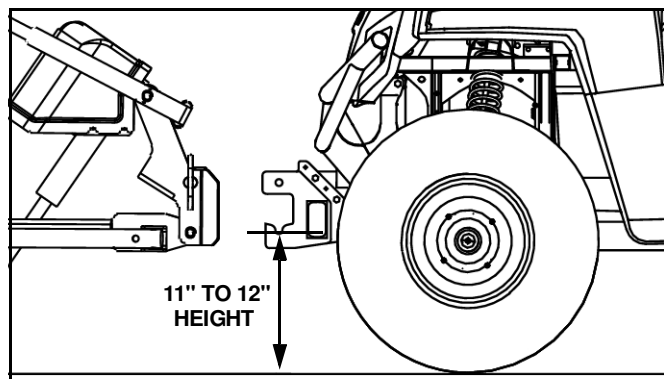

Figure 9

IMPORTANT: Height from the bottom of the lower pin slots on the UTV Mount to the ground should be between 11" and 12" to ensure proper operation.

16. Secure UTV Mount (#1) with (6) 3/8"-16 x 1-1/4" Cap Screws (#8) and (6) 3/8"-16 Lock Nuts (#9). (See Figure 10.)

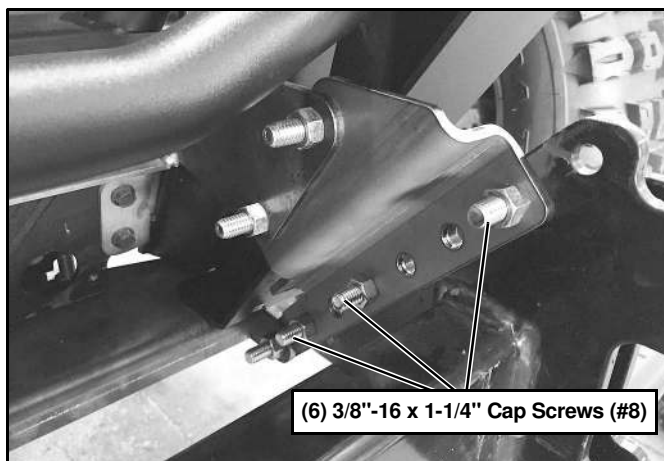

Figure 10

17. Tighten all hardware using the Torque Specification Chart provided.

TORQUE SPECIFICATIONS FOR STANDARD MACHINE HARDWARE

Bolt Size	GR.2 Dry	GR.5 Dry	GR.8 Dry	Metric Size	GR.8.8 Dry
1/4"	66*	9	12	M8	17
5/16"	11	17	25	M10	35
3/8"	20	30	45	M12	60
7/16"	32	50	70	M14	95
1/2"	50	75	110	M16	155
9/16"	70	110	150		
5/8"	100	150	220		
3/4"	175	260	380		
7/8"	170	430	600		
1"	250	640	900		

Note: These torque values are to be used for all hardware. Unless otherwise specified, all torque values must meet this specification.
Note: All torque values are in Ft.-Lbs unless otherwise stated
Note: *In-Lbs

NOTE: After 5 to 10 hours of snowplow usage, re-torque all Cap Screws!

PARTS LIST

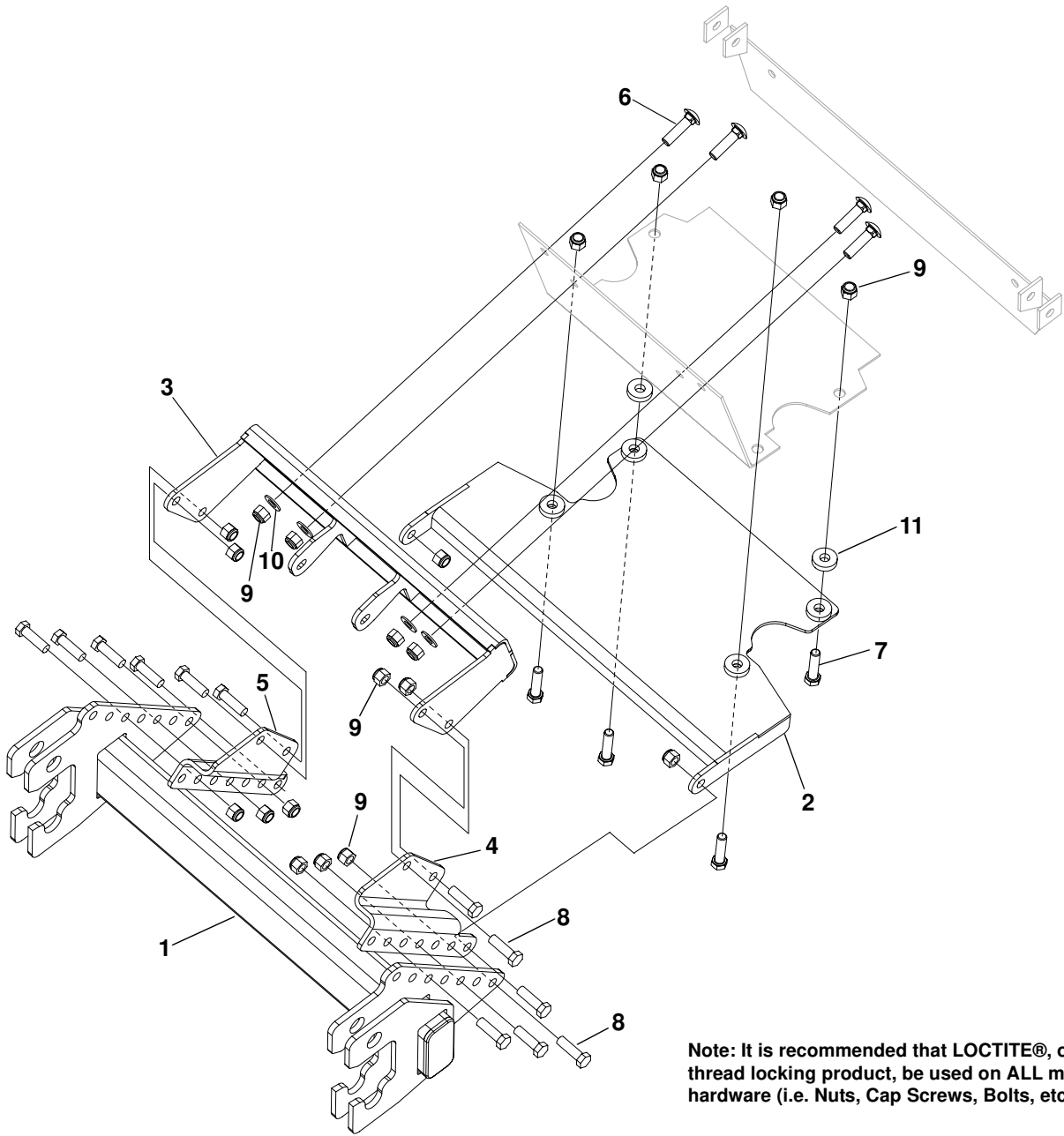

Note: It is recommended that LOCTITE®, or similar thread locking product, be used on ALL mounting hardware (i.e. Nuts, Cap Screws, Bolts, etc.).

ITEM	PART NO.	DESCRIPTION	QTY.
1		UTV Mount	1
2		Weldment, Bottom	1
3		Weldment, Top.....	1
4		Bracket, Front, Driver's Side	1
5		Bracket, Front, Passenger's Side.....	1
6		CB, 3/8"-16 x 1-1/2"	4
7		HHCS, 3/8"-16 x 1-1/2".....	4
8		HHCS, 3/8"-16 x 1-1/4".....	12
9		LN, 3/8"-16	20
10		PW, 3/8".....	4
11		Spacer, Polaris Ranger.....	2
12	96116667	Kit, HDWE (1304) (Includes items 6-11) (Not Shown).....	1

NOTES

NOTES

SNO-WAY® INTERNATIONAL, INC.



Hartford, WI 53027 USA
Website: www.snoway.com
©2017 Sno-Way® International