

# **SNO-WAY**®

**SNOW & ICE CONTROL EQUIPMENT**

## **ASSEMBLY & INSTALLATION INSTRUCTIONS**

**VEHICLE MOUNT KIT 99101168  
FOR UTV SERIES PLOW**

TO FIT  
2011 & Later - Can-Am Commander



©2013 Sno-Way® International

97101849A



1. THINK SAFETY, ALWAYS WEAR SAFETY GLASSES WHEN PERFORMING THE OPERATIONS PRESCRIBED IN THESE INSTRUCTIONS
2. READ ALL INSTRUCTIONS CAREFULLY BEFORE ATTEMPTING INSTALLATION
3. BEFORE BEGINNING WORK MAKE SURE TO SET PARKING BRAKE AND CHOCK WHEELS



## ASSEMBLY TOOLS NEEDED

Drill Bits	1/4" - 17/32"
Impact Sockets	7/16" - 1-3/8"
Wrenches	7/16" - 1-3/8"
Torque Wrench	
Rat Tail Pry Bar	
Center Punch and Hammer	
C-Clamp	
Screwdrivers	

## INSTALLATION NOTES

1. Vehicle should be parked on a level surface with a normal vehicle load on the FRONT suspension.
2. On some vehicles it may be necessary to raise or stiffen the suspension to decrease the vehicles front suspension sag with the snow plow in place.
3. Unless otherwise specified, mount all Vehicle Mount Kit Components to vehicle before tightening any hardware.
4. It is recommended that LOCTITE®, or similar thread locking product, be used on ALL mounting hardware (i.e. Nuts, Cap Screws, Bolts, etc.).
5. Items in parentheses ( ) refer to quantity required for this step. Items in parentheses with a pound sign (#) indicate the part number as found in the parts list on the last page of this document.  
Example: (2) 1/2" Lock Washers (#9).

## MOUNTING INSTRUCTIONS

1. Remove the side fascia located just ahead of the front tires from the passengers and driver's side of the vehicle.
2. Remove the front bumper if equipped from the vehicle by removing the (4) front mounting cap screws.

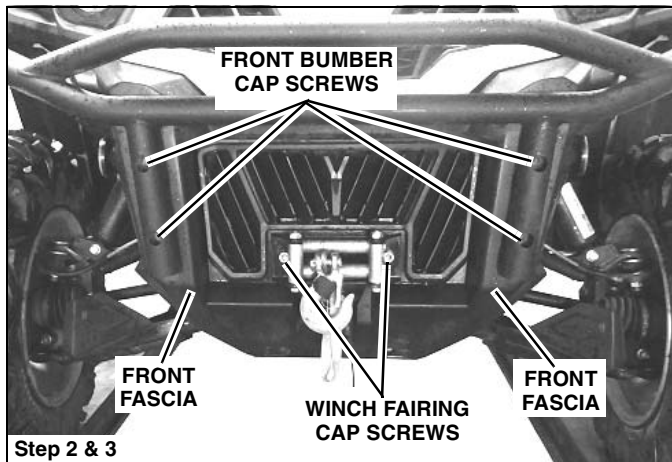

3. Remove the front fascia below the grill by removing (6) screws holding it in place. If the vehicle is equipped with a winch, it will be necessary to remove the winch fairing. To remove the winch fairing remove the four bolts underneath the winch holding it in place. Slide the winch back to gain access to the nuts on the cap screws holding the winch fairing in place. Save all hardware for re-installation.
4. If vehicle is equipped with a winch remove the winch and winch bracket.

5. Under the front fascia is a sub-frame that attaches to the front of the frame. The bumper and the front of the winch bracket bolt to it. At the bottom of the sub-frame remove the (2) cap screws that attach the sub-frame to the frame. At the top of the sub-frame loosen the (2) cap screws that hold the sub-frame to the frame.

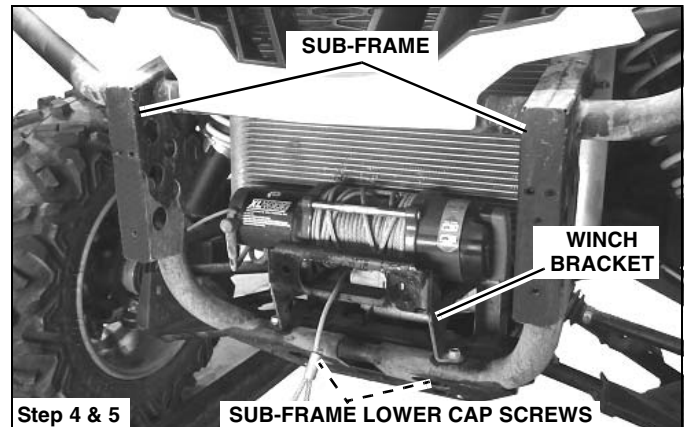

6. Pull the bottom of the commander sub-frame forward. Insert the tabs of bottom bracket (#2) between the commander sub-frame and frame. Insert the bottom (2) commander sub-frame cap screws to hold the bottom bracket (#2) in place. Mark the location of the rear holes in the bottom bracket (#2) on the frame of the commander.
7. Remove the bottom bracket (#2) and drill 13/32" holes in the commander frame thru both the bottom and top of the tube. If a 13/32" drill bit is not available use 7/16".

- Pull the bottom of the commander sub-frame forward. Insert the tabs of bottom bracket (#2) between the commander sub-frame and frame. Insert the bottom (2) commander sub-frame bolts thru the commander sub-frame and bottom bracket (#2) and into the frame. Insert (2) 3/8" x 4" cap screws (#11) thru the bottom bracket (#2) and frame. Secure with (2) 3/8" washers (#12) and (2) 3/8" locknuts (#13). Do not tighten hardware at this time.

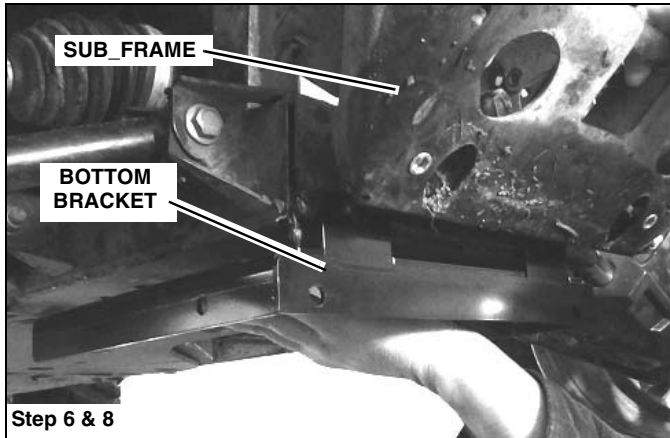

- Insert the top bracket (#3) and winch bracket (if equipped) behind the commander sub-frame. The holes in the top bracket (#3) align with holes in the U-shaped vertical frame member on the commander. The top holes of the winch bracket also mount to these holes. The plate of the top bracket (#3) should straddle the vertical frame member with the winch bracket fitting to the inside of the frame between the vertical frame member and the top bracket (#3). If no winch is installed add (3) 5/16" flat washers (#7) on each side between the top bracket (#3) and vertical frame member. Secure with (2) 5/16" x 2-1/2" cap screws (#6) and (2) 5/16" lock nuts (#8).

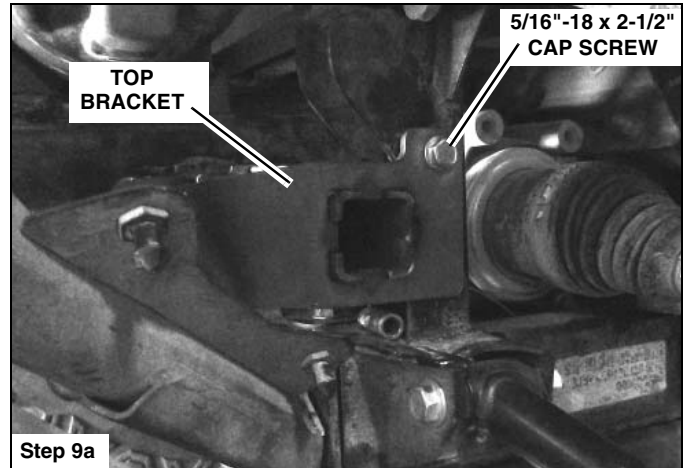
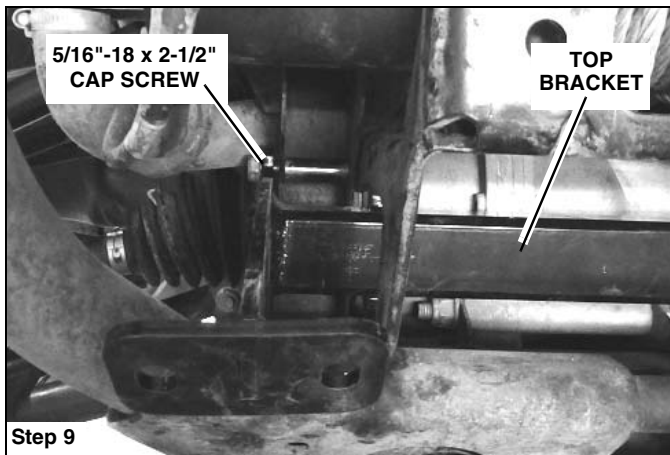

- Insert bottom bolts for winch bracket. Tighten all hardware for the sub-frame, winch bracket, top bracket (#3) and bottom bracket (#2). Before tightening top bracket (#3) push down on the front of the bracket to make sure the tube on the bracket is tight against the Commander frame.
- Re-install the front fascia after trimming it to fit around the bottom bracket (#2).
- Re-install the winch fairing and winch.
- Align the bottom holes in the driver's side front bracket (#4) with the holes in the bottom bracket (#2). Insert (1) 3/8"-16 X 1" cap screw (#9), (1) 3/8" flat washer (#12), and (1) 3/8" lock nut (#13) in the front hole. Insert (1) 3/8"-16 X 1 cap screw (#9) and (1) 3/8" lock nut (#13) in the side hole. Mark the location of the upper slots. Remove the bracket.
- Drill or cut a 3/4" dia. hole thru the front fascia that lines up with both the slots in the DS front bracket (#4) and the slots in the top bracket (#3) behind the fascia.
- Insert a spacer (#14) into each hole. Insert (1) 3/8"-16 X 1-1/2" cap screw (#10), (2) 3/8" flat washers (#12), and (1) 3/8" lock nut (#13) thru each slot. Insert (1) 3/8"-16 X 1 cap screw (#9), (1) 3/8" flat washer (#12) and (1) 3/8" lock nut (#13) in the bottom front hole. Insert (1) 3/8"-16 X 1 cap screw (#9), and (1) 3/8" lock nut (#13) in the bottom side hole. Do not tighten.
- Repeat steps 13-15 for the passenger's side front bracket (#5).

17. Position the UTV Mount (#1) on the machine. Align the mount holes with the Front Brackets (#4 and #5) to provide an 11" to 12" height between the lower pin slots and the ground.

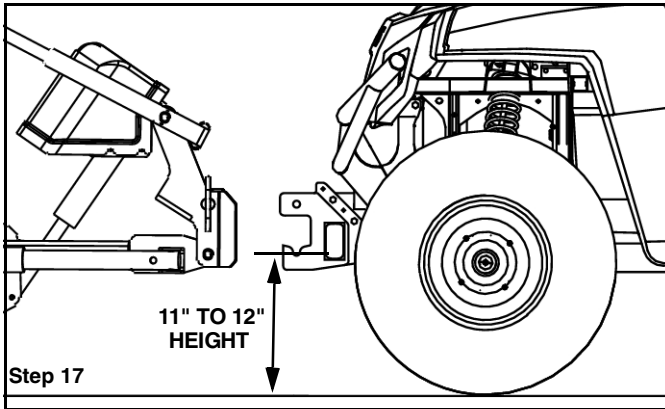

**IMPORTANT:** Height from the bottom of the lower pin slots on the UTV Mount to the ground should be between 11" and 12" to ensure proper operation.

18. Secure the UTV Mount (#1) to the Front Brackets (#4, #5) using (6) 3/8"-16 x 1-1/4" Cap Screws (#15) and (6) 3/8" Locknuts (#13) evenly spaced on each side.

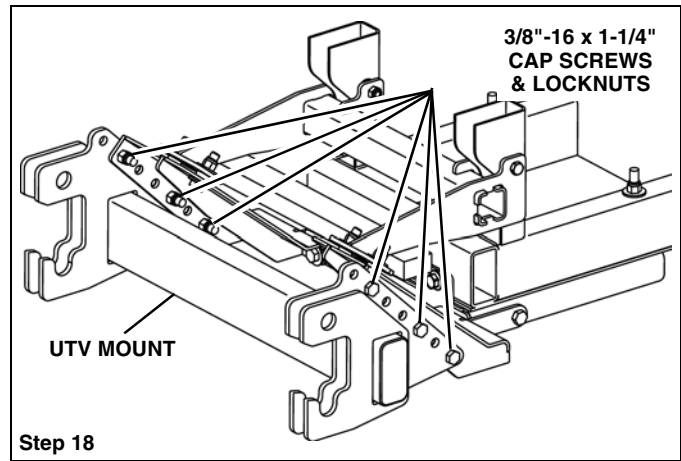

19. Torque all hardware using the Torque Specification Chart below:

TORQUE SPECIFICATIONS FOR STANDARD MACHINE HARDWARE					
Bolt Size	GR.2 Dry	GR.5 Dry	GR.8 Dry	Metric Size	GR.8.8 Dry
1/4"	66*	9	12	M8	17
5/16"	11	17	25	M10	35
3/8"	20	30	45	M12	60
7/16"	32	50	70	M14	95
1/2"	50	75	110	M16	155
9/16"	70	110	150		
5/8"	100	150	220		
3/4"	175	260	380		
7/8"	170	430	600		
1"	250	640	900		

These torque values are to be used for all hardware. Unless otherwise specified, all torque values must meet this specification.  
All torque values are in Ft.-Lbs unless otherwise stated  
\*In-Lbs

**REMEMBER** After 5 to 10 hours of snowplow usage, re-torque all hardware!

# PARTS LIST

Note: It is recommended that LOCTITE®, or similar thread locking product, be used on ALL mounting hardware (i.e. Nuts, Cap Screws, Bolts, etc.).

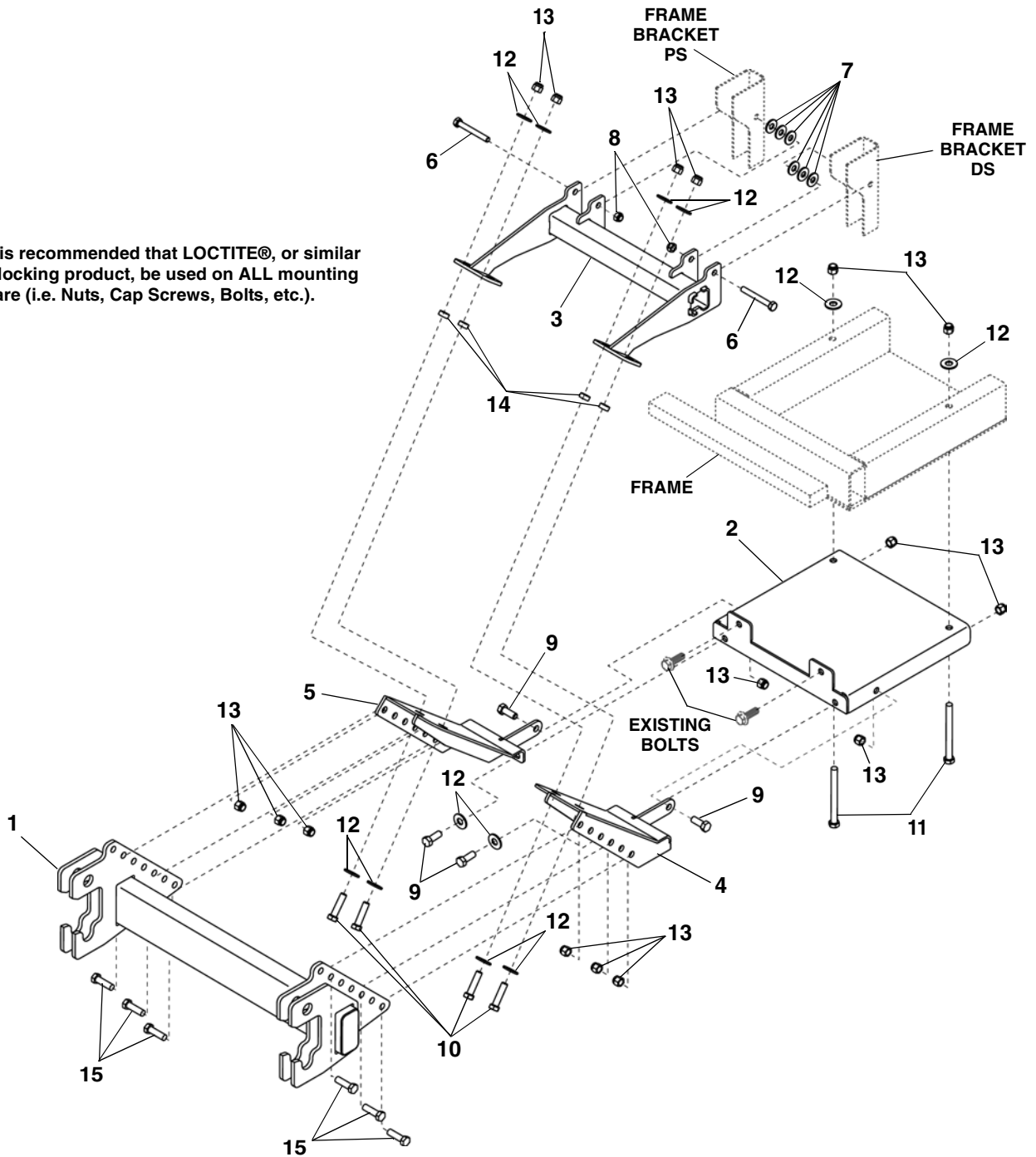

# PARTS LIST

ITEM	PART NO.	DESCRIPTION	QTY.
1		UTV Mount .....	1
2		Weldment, Bottom, Can-Am.....	1
3		Weldment, Top, Can-Am .....	1
4		Weldment, Front, DS, Can-Am.....	1
5		Weldment, Front, PS, Can-Am.....	1
6		HHCS, 5/16"-18 x 2-1/2" .....	2
7		PW, 5/16" .....	6
8		LN, 5/16"-18 .....	2
9		HHCS, 3/8"-16 x 1" .....	4
10		HHCS, 3/8"-16 x 1-1/2" .....	4
11		HHCS, 3/8"-16 x 4" .....	2
12		PW, 3/8" .....	12
13		LN, 3/8"-16 .....	14
14		Spacer, Can-Am .....	4
15		HHCS, 3/8"-16 x 1-1/4" .....	6
16	96115132	Kit, HDWE (Not Shown) (Includes Items 6-14) .....	1

SNO-WAY® INTERNATIONAL, INC.



Hartford, WI 53027 USA  
Website: [www.snoway.com](http://www.snoway.com)  
©2013 Sno-Way® International