

SNO-WAY®

SNOW & ICE CONTROL EQUIPMENT

INSTALLATION & OWNER'S MANUAL

UTV SERIES SNOW PLOWS

FOR GRAVITY HYDRAULICS
WITH SERIAL NUMBER AFTER UTVG100000



Sno-Way®, Down Pressure® and EIS® are registered trademarks of Sno-Way International, Inc.
ProControl™, MegaBlade™, V-Wing™, E-Z Switch™, Revolution™, MaxAdjust™, SpeedLock™, and QuickJack™
are trademarks of Sno-Way International, Inc.

©2015 Sno-Way® International

97101810C

TABLE OF CONTENTS

	Page
INTRODUCTION	2
SAFETY	3
INSTALLATION INSTRUCTIONS	4
General	4
Electrical Installation	4
Mechanical Installation	5
Mounting Snow Plow To Vehicle	6
Removing Snow Plow From Vehicle	8
MAINTENANCE	9
General	9
Break In Period	9
To Remove Excessive Free Play	9
Periodic Inspection	9
Plow Storage	9
Fluid Requirements	10
Changing Oil and Cleaning Filter Screen	10
Cutting Edge	11
Trip Spring Adjustment	11
PLOWING OPERATION	12
Operating Class	12
Before the Season Begins	12
Transporting Vehicle With Plow Attached	12
Plowing Like A Pro	12
Clearing Driveways	13
Clearing Parking Lots	13
TROUBLESHOOTING	14
Introduction	14
Troubleshooting Guide	14
THEORY OF OPERATION	19
Hydraulic Power Unit	19
Hydraulic Controls	19
Electro-Hydraulic Operation	19
Raise Mode Of Operation	19
Lower Mode Of Operation - Gravity Down and Float	19
Angle Left or Right Mode of Operation	19
HYDRAULIC SCHEMATIC	20
WIRING SCHEMATIC	21
TORQUE SPECIFICATIONS	22

INTRODUCTION

This manual was written for the assembly, installation and maintenance of your new Sno-Way plow. Most importantly, this manual provides an operating plan for safe use. Refer to the Table of Contents for an outline of this manual.

Please keep this manual with your machine at all times as reference material and so it can be passed on to the next owner if the machine is sold.

We require that you read and understand the contents of this manual COMPLETELY, especially the chapter on SAFETY, before attempting any procedure contained in this manual.



The Society of Automotive Engineers has adopted this SAFETY ALERT SYMBOL to pinpoint characteristics that, if NOT carefully followed, can create a safety hazard. When you see this symbol in this manual or on the machine itself, BE ALERT!, your personal safety and the safety of others, is involved.

• Defined in the next column, are the SAFETY ALERT messages and how they will appear in this manual.

	WARNING
FAILURE TO FOLLOW CAN RESULT IN INJURY OR DEATH.	

	CAUTION
Information, that if not carefully followed, can cause injury or damage to equipment!	

NOTE: Additional information concerning the equipment or the procedure that may or may not be contained elsewhere in this manual.

BE AWARE! It is illegal to remove, deface or otherwise alter the safety decals mounted on this equipment.

Record the Power Pack Model Number, Power Pack Serial Number, Controller Serial Numbers, Blade Model Number, Blade Serial Number and the Pump Serial Number in the space provided below as a handy record for quick reference. The Power Pack Serial Number is located on the A-Frame (driver's side near the front), the Blade Serial Number is located on one of the middle ribs of the blade. This plate contains information that your

Dealer needs to answer questions or to order replacement parts, if needed, for your unit.

NAME PLATE DATA	
POWER PACK MODEL NUMBER	_____
POWER PACK SERIAL NUMBER <small>(Located on A-Frame)</small>	_____
CONTROLLER SERIAL NUMBERS:	
TRANSMITTER S.N.	_____
RECEIVER S.N.	_____
BLADE MODEL NUMBER	_____
BLADE SERIAL NUMBER <small>(Located on Blade Frame)</small>	_____
PUMP SERIAL NUMBER	_____
(FILL IN)	

DEALER	
NAME	_____
ADDRESS	_____
CITY	STATE ZIP
PHONE ()-	_____
(FILL IN)	

ORIGINAL PURCHASER	
NAME	_____
ADDRESS	_____
CITY	STATE ZIP
PHONE ()-	_____
(FILL IN)	

We reserve the right to make changes or improve the design or construction of any part(s) without incurring the obligation to install such parts or make any changes on any unit previously delivered.

Graphics and illustrations may be used which may show equipment and/or options not included in every installation without incurring the obligation to install such parts or make changes on units previously delivered.

Sno-Way Service Parts Manuals are available on-line or at your authorized Sno-Way dealer. Request part number 97101870 & 97101915 for the UTV Series Snow Plow. Factory contact information is available at www.snoway.com.

SAFETY

BEFORE ATTEMPTING ANY PROCEDURE IN THIS BOOK, READ AND UNDERSTAND ALL THE SAFETY INFORMATION CONTAINED IN THIS SECTION. IN ADDITION, ENSURE ALL INDIVIDUALS WORKING WITH YOU ARE ALSO FAMILIAR WITH THESE SAFETY PRECAUTIONS.

For your safety Warning and Information Decals have been placed on this product to remind the operator to take safety precautions. It is important that these decals are in place and are legible before operation begins. New decals can be obtained from Sno-Way or your local dealer.

REMEMBER The careful operator is the best operator. Most accidents are caused by human error. Certain precautions must be observed to prevent the possibility of injury to operator or bystanders and/or damage to equipment.

NEVER operate plow when under the influence of alcohol, drugs or other medications that could hamper your judgement and reactions. An accident may result in serious injury or death to other persons or yourself.

ALWAYS operate vehicle in a well-ventilated area. The carbon monoxide in exhaust gas is highly toxic and can cause serious injury or death.

NEVER allow hands, hair or clothing to get near any moving parts such as fan blades, belts and pulleys. Never wear neckties or loose clothing when working on the vehicle.

NEVER wear wrist watches, rings or other jewelry when working on the vehicle or individual equipment. These things can catch on moving parts or cause an electrical short circuit that could result in personal injury.

ALWAYS wear safety goggles when working on the vehicle to protect your eyes from battery acid, gasoline, and dust or dirt from flying off of moving engine parts.

ALWAYS be aware of and avoid contact with hot surfaces such as engine, radiator, and hoses.

ALWAYS wear safety glasses with side shields when striking metal against metal! In addition, it is recommended that a softer (non-chipable) metal material be used to cushion the blow. Failure to heed could result in injury to the eye(s) or other parts of the body.

NEVER allow children or unauthorized person to operate this unit.

NEVER exceed 25 m.p.h. when snow plow is attached to vehicle. Braking distances may be increased and handling characteristics may be impaired at speeds above 25 m.p.h.

ALWAYS lock the vehicle when unattended to prevent unauthorized operation of the plow.

ALWAYS check the job site for terrain hazards, obstructions and people.

NEVER exceed 10 m.p.h. when plowing. Excessive speed may cause serious injury and damage of equipment and property if an unseen obstacle is

encountered while plowing.

ALWAYS position blade so it does not block path of headlamps beam. Do not change blade positions while traveling. An incorrect plow position blocking headlamp beam may result in an accident.

ALWAYS check surrounding area for hazardous obstacles before operating this unit.

ALWAYS inspect the unit periodically for defects. Parts that are broken, missing or plainly worn must be replaced immediately. The unit, or any part of it should not be altered without prior written approval of the manufacturer.

ALWAYS shut off the vehicle engine, place the transmission in Neutral or Park, turn the ignition switch to the "OFF" position, firmly apply the parking brake of the vehicle and turn "OFF" the plow controller before attaching or detaching the blade from the vehicle or when making adjustments to the blade.

ALWAYS inspect lift system bolts and pins whenever attaching or detaching the plow, and before traveling. Worn or damaged components could result in the plow dropping to the pavement while driving, causing an accident.

ALWAYS keep hands and feet clear of blade and A-Frame when attaching or detaching plow.

NEVER place fingers in A-frame or mount lug holes to check alignment when attaching snow plow. Sudden motion of the plow could severely injure a finger.

NEVER stand between the vehicle and blade or directly in front of blade when it is being raised, lowered or angled. Clearance between vehicle and blade decreases as blade is operated and injury or death can result from blade striking a body or dropping on hands or feet.

NEVER work on the vehicle without having a fully serviced fire extinguisher available. A 5 lb or larger CO² or dry chemical unit specified for gasoline, chemical or electrical fires, is recommended.

NEVER smoke while working on the vehicle. Gasoline and battery acid vapors are extremely flammable and explosive.

NEVER use your hands to search for hydraulic fluid leaks; escaping fluid under pressure can be invisible and can penetrate the skin and cause injury! If any fluid is injected into the skin, see a doctor at once! Injected fluid MUST be surgically removed by a doctor familiar with this type of injury or gangrene may result.

REMEMBER it is the owner's responsibility for communicating information on the safe use and proper maintenance of this machine.

INSTALLATION INSTRUCTIONS

General

Install the subframe on the vehicle using the instructions supplied with the subframe package. The pin height should be 11" - 12" off the ground. (See Figure 1-1).

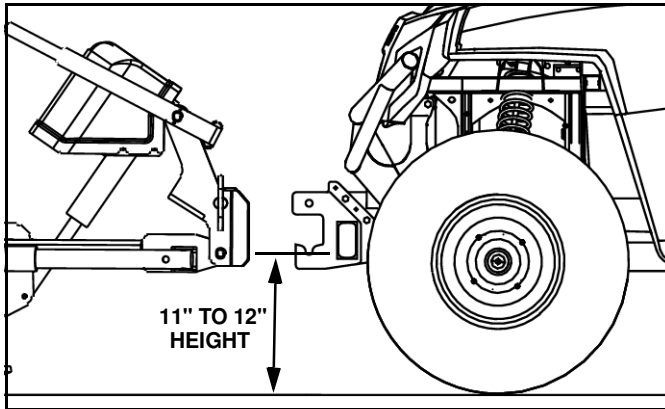



Figure 1-1

Electrical Installation

1. Remove the battery power harness and power harness parts bag from the power pack box.

NOTE: Take extra time needed to plan the routing of wiring harnesses. Make sure harnesses do not interfere with, or contact, any moving parts and route wires away from excessive heat areas. Read all the instructions carefully to ensure a safe and professional installation.

**WARNING**

Disconnect the vehicle NEG. (-) battery cable while performing steps 2 - 7 to avoid serious bodily injury from electrical shock, fire, or explosion. Do not re-connect battery cable until indicated in step 8.

FAILURE TO FOLLOW CAN RESULT IN INJURY OR DEATH

2. Mount the fuse holder near the battery using (2) #10 x 1" self tapping screws.

3. Take the cover off of the fuse holder. Place the end of the 6" long power wire with the small ring terminal over one of the studs. (See Figure 1-2).

4. Attach the other end of the 6" long power wire to the positive terminal of the battery. (See Figure 1-3).

5. Attach the power harness red wire to the other stud on the fuse holder.

6. Place the fuse between the studs and secure with supplied nuts. Replace fuse holder cover.

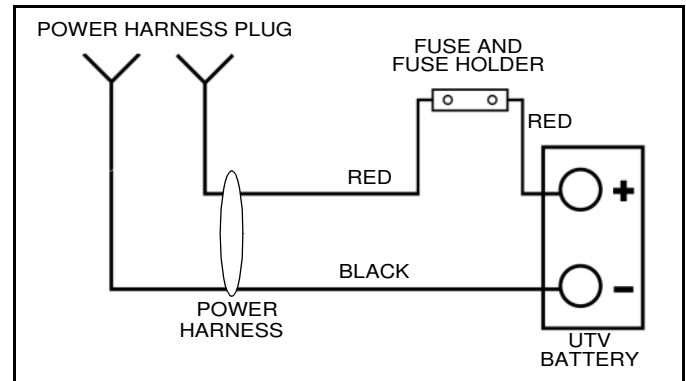

Figure 1-2

7. Route power harness to convenient point on front of vehicle for connection to plug.

8. Attach the power harness black wire to the NEG. (-) terminal of the battery and re-connect the negative battery terminal.

9. Spray all terminal connections with a battery terminal protective coating.

10. Secure harness with plastic tie straps.

11. Install UTV control harness if needed, using instructions included with controls.

12. Apply included dielectric grease to all connectors.

NOTE: An adapter is recommended for vehicles with a side post battery. (See Figure 1-3). (Adapters can be purchased from your Sno-Way dealer, Part #96100773.

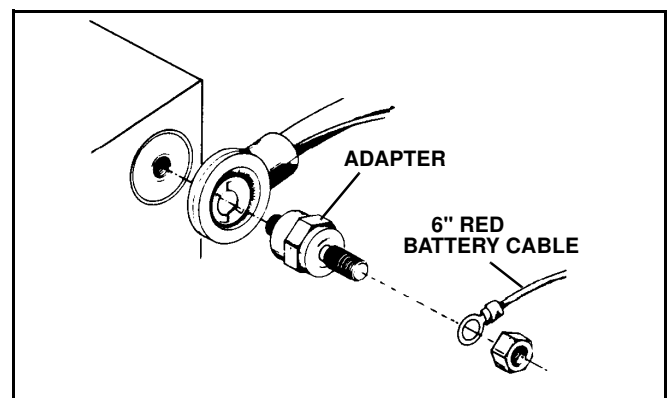

Figure 1-3

Mechanical Installation

IMPORTANT: Graphics and illustrations may be used which may show equipment and/or options not included in every installation.

1. Remove the blade parts box (part number 96114989) from the power pack carton. Inside will be the trip springs, spring mounts, spring mount plates, and blade hardware bag (part number 96114901).

2. Lay blade face down on floor. Remove four shipping brackets. (See Figure 1-4)

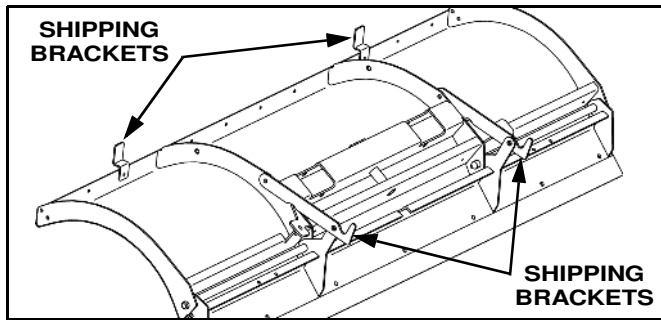

Figure 1-4

3. Place blocking under the upper blade so that the lower blade swings forward and the stop areas on the upper and lower blade touch. (See Figure 1-5)

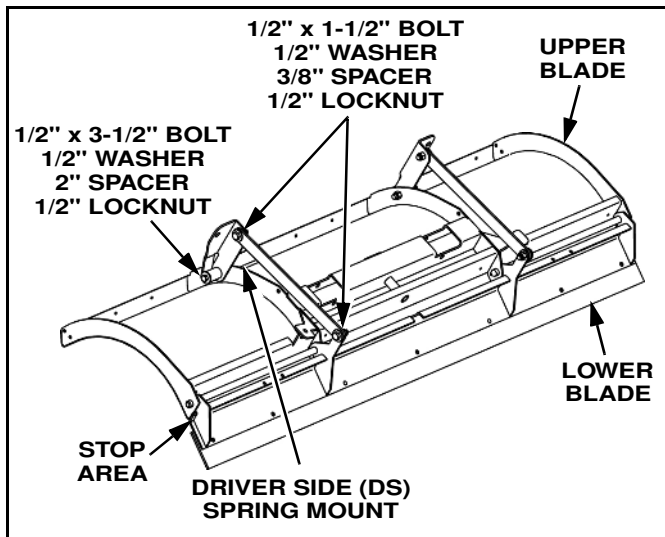

Figure 1-5

4. Take out the Drivers Side Spring Mount. Place a 2" spacer in the tube on the mount. (See Figure 1-5)

5. Bolt the Drivers Side Spring Mount to the Drivers Side inner rib on the upper blade using a 1/2" hardened washer on the spacer side, 1/2" x 3 1/2" bolt, and 1/2" lock nut. (See Figure 1-5)

6. Take a Spring Mount Plate and two 3/8" spacers and bolt it to the Spring Mount and the tab on the lower blade. Use two 1/2" hardened washers on the spacer side, two 1/2" X 1 1/2" bolts, and two 1/2" lock nuts. (See Figure 1-5)

7. Install the Passengers Side Spring Mount and repeat steps 4-6 on the passenger side of the blade.

8. Hook one spring on lower blade bracket. (See Figure 1-6)

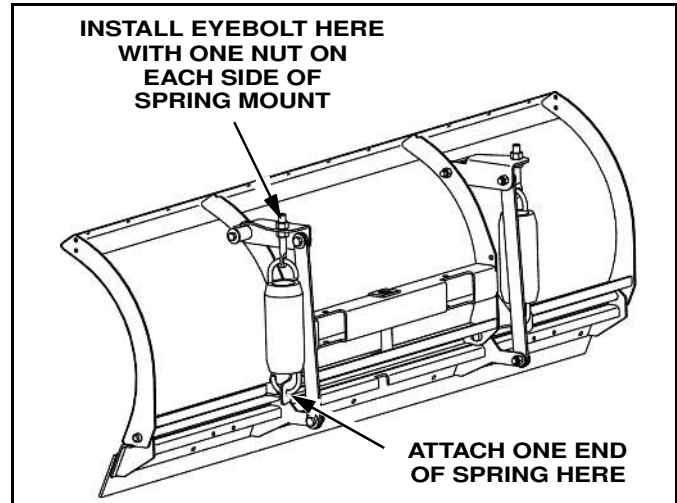

Figure 1-6

9. Thread a nut fully on one eyebolt. Hook free end of spring on eyebolt and insert eyebolt into Spring Mount. Loosely install a nut. (See Figure 1-6)

10. Repeat step 8 to install second spring.

11. Tighten top nut on both spring eyebolts until a .015" feeler gauge can pass between two or more coils. (A 3X5 postcard is approximately .015" thick.)

12. Remove power unit and the UTV hardware bag (part number 96114897) from the carton.

13. With the blade still face down pick up the power unit and slide the A-frame over the blade. Insert the 3/4" x 8 1/2" bolt from the bottom up and secure with a 3/4" lock nut. (See Figure 1-7)

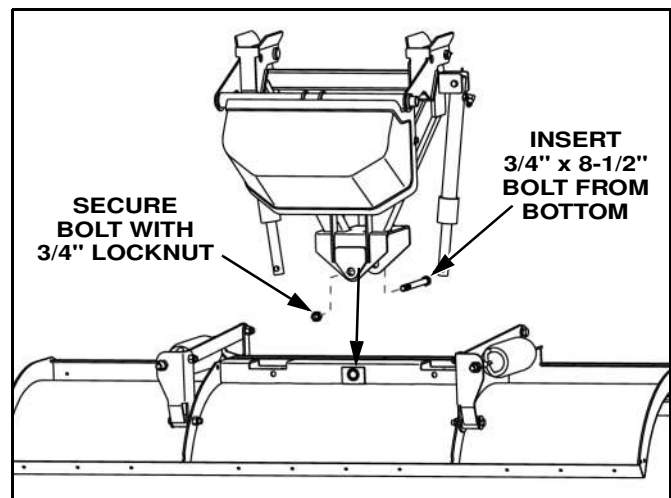

Figure 1-7

14. Install the receiver using instructions included with the controls package. The 1/4" X 6" bolt and 1/4" lock nut used to secure the receiver are located in the parts bag.

15. Set the lower hitch pins into the slot on the UTV subframe. Fill the reservoir with hydraulic fluid. Plug in power and control harness and put the plow into float mode. Using the mounting lever rotate the lift bar into position. Secure the plow to the mount with red handled hitch pins and the lynch pins. See "Mounting Snow Plow To Vehicle" that follows for more information.

16. Extend the swing cylinders using plow control to align holes in cylinder rod with holes in the upper blade frame. Secure cylinders to the upper blade frame using 1/2" x 4" bolts, spacers, and 1/2" lock nut. (See Figure 1-8)

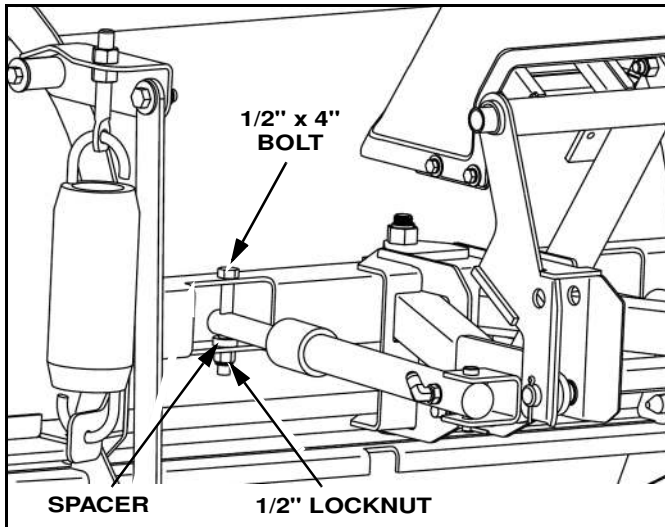

Figure 1-8

17. Cycle all plow functions and refill reservoir. Repeat until all air is removed from hydraulic system.

IMPORTANT: Review the "Break In Period" section on page 9 of the Maintenance section to determine if the 3/4" bolt installed in step 12 is tightened appropriately.

18. Place pump cover over pump and tighten four bolts.

Mounting Snow Plow To Vehicle

1. Drive UTV up to plow. Align lift bar frame outside of subframe lugs. Grab the tube at the top of the lift bar, pick up rear of plow and set lower hitch pins into slot of subframe. (See Figure 1-9).

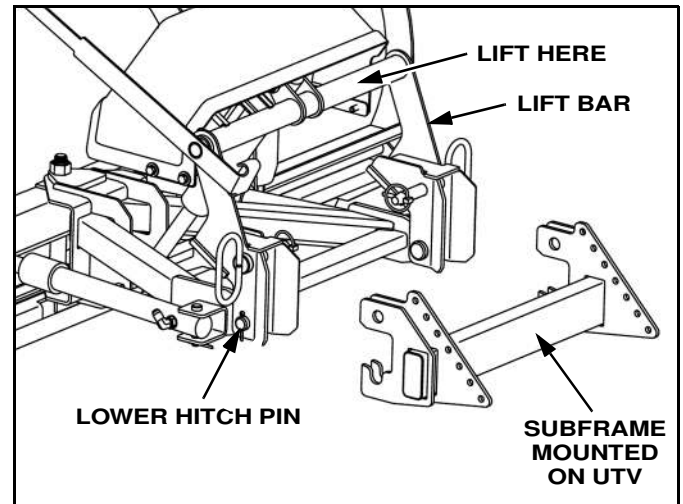

Figure 1-9



WARNING

Pressing the blade angle functions will result in the A-frame swinging if it is not secured to the UTV. Do not press the angle function during plow installation.

FAILURE TO FOLLOW CAN RESULT IN INJURY OR DEATH

2. Plug in power harness and plug controller into plow.



WARNING

The power cable in front of the UTV is wired directly to the battery. The power cable is always energized, even if the UTV is turned off. Always replace the protective cap after disconnecting the plow power cable. Allowing an unprotected plug to contact metal parts of the UTV may cause electrical component damage. Never use a metal object to clean the plug contacts.

FAILURE TO FOLLOW CAN RESULT IN INJURY OR DEATH

3. Turn on control and place plow in float mode by moving pushing joystick to lower position.

4. Insert handle into the lift bar tube and push or pull the handle toward the UTV to rotate lift bar into position. (See Figure 1-10).

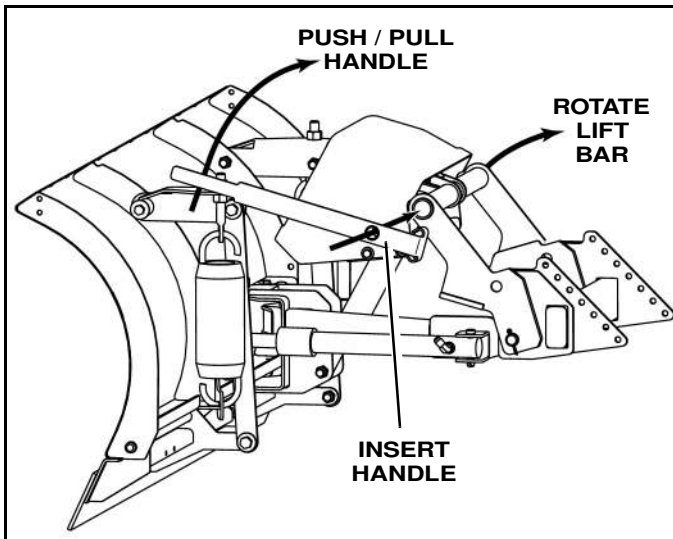

Figure 1-10

5. With plow still in float mode insert upper hitch pins and secure with lynch pins. Use handle to help align holes if needed. (See Figure 1-11)

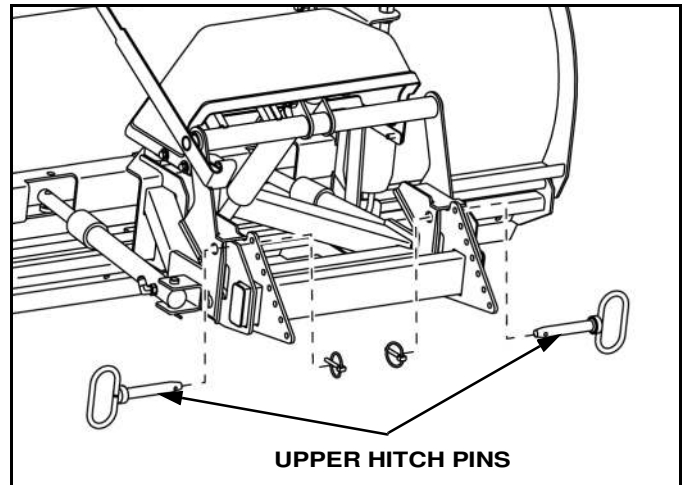

Figure 1-11

6. Remove handle and unplug plow from control.
7. Plug control harness on plow into UTV. Plug plow control into UTV harness.
8. Raise, lower and angle plow to make sure no hoses or wires pinch in the plow mechanism.



WARNING

Make sure that upper hitch pins are inserted before moving UTV. Hitch pins not fully secured could result in the plow separating from the UTV.

FAILURE TO FOLLOW CAN RESULT IN INJURY OR DEATH

Removing Snow Plow From Vehicle

Choose a location for the plow storage, which will allow the plow to be removed from the vehicle and not be moved after removal. A dry, protected area is recommended.

1. Lower plow to the ground, put vehicle in park or neutral, turn off the engine and set the parking brake.

2. Disconnect the plow control harness and replace the protective cap. (See Figure 1-12)

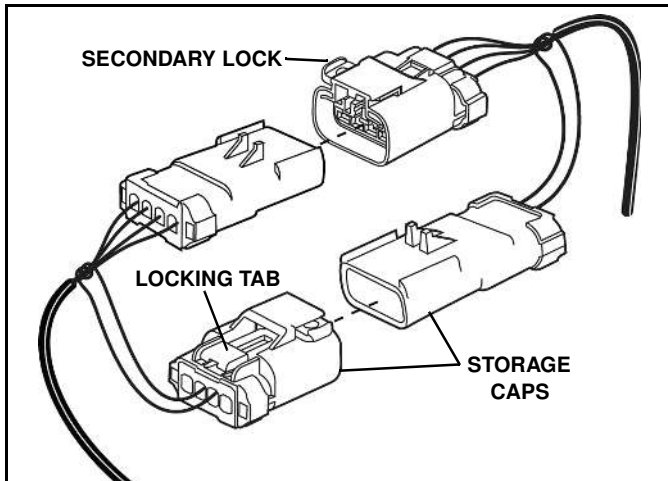

Figure 1-12

3. Remove upper hitch pins. (See Figure 1-13).

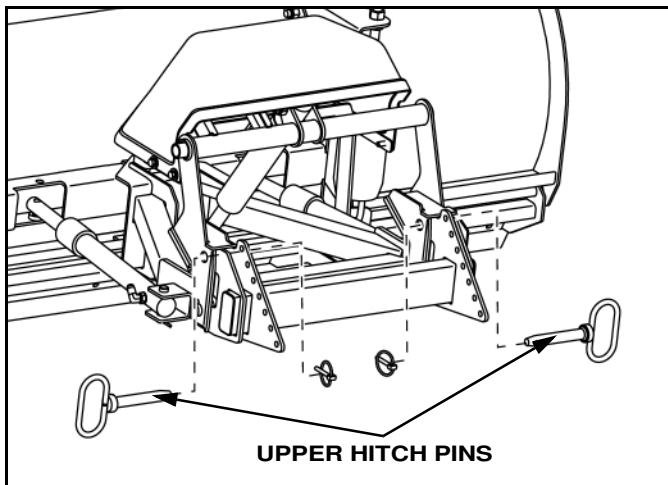

Figure 1-13

4. Remove controller from UTV and plug into plow control harness.

5. Rotate lift bar forward by pressing up function on controller. (See Figure 1-14).

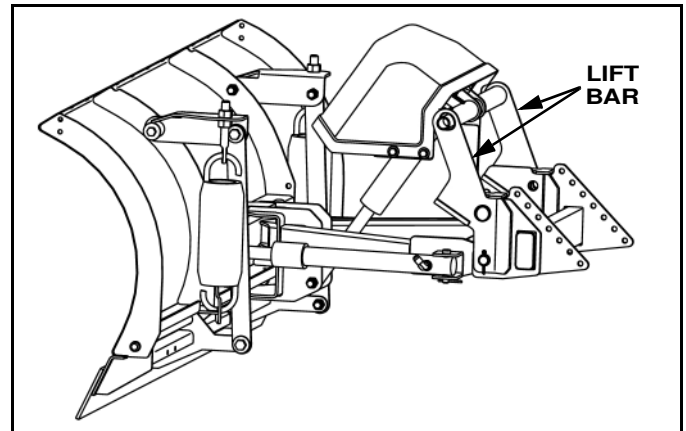

Figure 1-14

6. Disconnect power harness and replace protective caps. Grab tube on lift bar. Lift rear of plow and pull away from UTV. (See Figure 1-15).

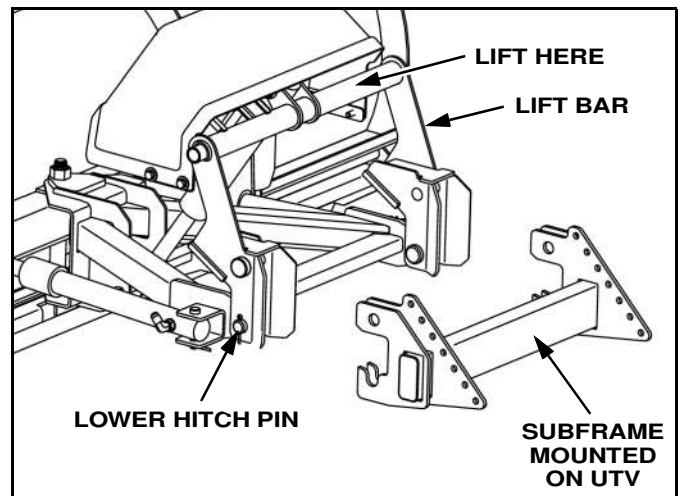

Figure 1-15

7. Check and replace any worn or damaged components, such as cutting edges, deflectors, and bushings.

MAINTENANCE

General



WARNING

Before servicing plow, lower plow to the ground and disconnect main power harness.

FAILURE TO FOLLOW CAN RESULT IN INJURY OR DEATH

- Before operating, perform a through visual inspection of the equipment. Look for fluid leaks, cracked, bent or broken components, loose nuts, bolts or attachments and proper fluid levels.
- A clean system is essential to long pump life and proper performance.

IMPORTANT: Hydraulic fluid packaged with power unit is Type 5606. If additional oil is added it must be compatible with Type 5606. If another type of oil has been used in the system the same type of oil must be used for topping off the system

- Do **NOT** use synthetic oil.
- Oil must contain an anti-foam additive.
- Ensure all electrical connections are clean and tight.
- To prevent rust from forming, clean and repaint exposed metal surfaces.
- **NEVER** operate the equipment with the protective covers or guards removed.

Break In Period

The plow will go through a break in period during which the A-frame and upper blade frame will settle in. After 15-20 hours of operation check for free play of the A-frame and upper blade frame pivot.

1. Raise the plow and support with jackstands or blocking.
2. Push down on end of blade as far as it will go on the right or left side. Measure and record the distance from the ground to the bottom edge of the wear strip.
3. Pull upwards on the same end of the plow as far as it will go. Measure and record the distance from the ground to the bottom edge of the wear strip.
4. Subtract the two measurements. If the number is greater than 1-1/2" then the free play needs to be adjusted.

To Remove Excessive Free Play

1. Tighten the pivot bolt nut (typically 1/6 to 1/3 turn, one or two flats).

Periodic Inspection

After every 20 hours of operation perform the following inspections:

1. Inspect plow assembly including sub frame for any damage or excessive wear. Replace parts as necessary.
2. Inspect all fasteners (Plow & Vehicle Mount) to insure they are properly tightened. Re-tighten loose fasteners to the proper torque. Loose fasteners on the Power Unit to the Lift Cylinder and Vehicle Mount must have the nylock nuts replaced and tightened while using Sno-Way thread locker 96115529. (Refer to torque specification chart in this manual).
3. Apply a small amount of light oil to: Lower hitch pins, pivot pins between the upper and lower blade frame and pivot pins at lift and swing cylinders. Also lubricate trip spring pivot points. (See Figure 2-1).

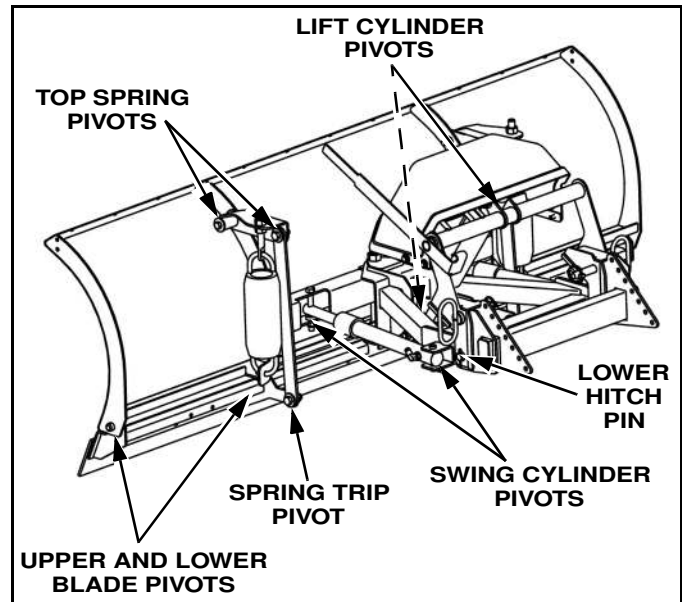

Figure 2-1

4. If wear is noticed between the A-frame and the upper blade frame, apply a good quality anti-seize lubricant to this area.

Plow Storage

When storing the plow for long periods of time use the following guidelines.

1. To prevent corrosion, coat the exposed portion of the cylinders with light grease.
2. Grease all pivot points.
3. Fill hydraulic reservoir to the fill line to minimize trapped air.
4. Place dielectric grease on the terminals of all electrical plugs, including those under pump cover. Make sure protective caps are in place or connectors are plugged together.

5. Check and replace any worn or damaged components, such as cutting edges, deflectors, and bushings.

Fluid Requirements

IMPORTANT: Hydraulic unit comes from factory shipped with type 5606 hydraulic oil. If additional oil is added it must be compatible with Type 5606.

It is recommended that the fluid in the hydraulic system be changed once a season.

NOTE: Type 5606 oil is rated to -60 deg. F, when Type 5606 is not available Exxon UNIVIS J13 or equivalent may be used.

Do NOT use synthetic oil.
Oil must contain an anti-foam additive.



CAUTION

- Using the proper oil increases the life expectancy of the most critical part of your plow; the hydraulic power unit.
- Failure to use the proper oil can cause extensive damage to the power unit, seals and hydraulic cylinders.

Changing Oil and Cleaning Filter Screen

NOTE: Oil should be changed at the beginning of every season. We recommend cleaning the filter screen at every oil change; this will help ensure maximum life and maximum performance from the pump assembly.



WARNING

- Allow the system to cool down before draining oil or handling system components. Burns can result from contact with hot oil.
- Never disconnect any hydraulic line or fitting with the plow in the raised position. Always lower the plow and relieve pressure before removing any lines or caps.

FAILURE TO FOLLOW CAN RESULT IN INJURY OR DEATH

1. Move plow to a clean, dry area with a solid surface. Lower the plow to the ground, put vehicle in park or neutral, turn off the engine and vehicle ignition, set the park brake, and turn off the plow controller.

2. To prevent inadvertent short circuit or electrical shock, disconnect the power harness and control harness at the vehicle bumper.

3. Loosen the four screws holding on the pump cover and remove the pump cover.

4. Using a suction gun, drain the oil (most of it) from the power unit reservoir.

5. Remove the breather hose from the tank by pushing on the end of the fitting and then pulling the hose out at the same time.

6. Loosen the band clamp, which holds the reservoir on the center section. Twist the reservoir so that it is parallel with the pump cover mounting plate located behind it. Pull the reservoir out while moving it up and down until it separates from the center section. Place a container under the power unit to catch spilled oil. Note the position of the reservoir oil pick-up tube and be sure the tube is in the same position when the filter is removed and installed.

7. Clean the inside and outside of the reservoir with a suitable solvent.

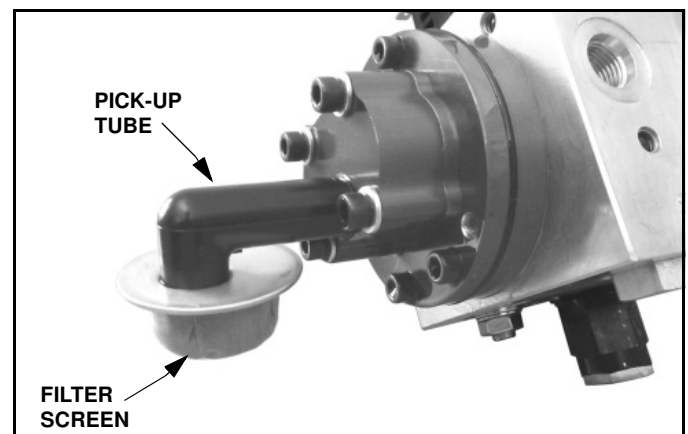

Figure 2-2

8. Pull the filter screen from the oil pick up tube and clean with a suitable solvent. Blow-dry the filter from the inside with low-pressure air. (See Figure 2-2).

9. Carefully re-install the filter screen. Use care when handling the screens to avoid damage.

10. Inspect the O-ring between the reservoir and the power unit center section and replace it if damaged. Wipe the surface of the O-ring with fresh oil and then push the reservoir onto the center section of the power unit. Be sure to reposition the reservoir so that the oil filler cap is in the same location as before removal.

11. Tighten the band holding the reservoir to 80-120 lb-in. torque.

12. Remove the lift cylinder hose(s) from the valve block. Remove the swing cylinder hoses from the fitting in the valve block. Mark hoses before removal to be certain they are reinstalled in the correct location.

13. Place the hoses in a container to catch oil expelled from cylinders. Cycle the lift cylinder by disconnecting hitch pins and pushing and pulling on lift bar. Cycle swing cylinders by disconnecting from swing frame and pushing and pulling on cylinder rod.

14. Reconnect swing cylinders and install hitch pins.

15. Reconnect hoses. Lift cylinder hoses are torqued to 20-25 lb-ft and swing cylinder hoses are torqued to 12-15 lb-ft.



CAUTION

Do Not use Teflon tape or pipe dope on hydraulic fittings. These can dislodge and jam valves in the hydraulic system.

16. Fill the hydraulic reservoir with type 5606 hydraulic fluid until the fluid registers full on the sight line.

NOTE: Vehicle must be parked on level ground and plow must be in lowered position in order to properly check the reservoir level.

17. Refer to controls manual and cycle plow to remove air from hydraulic system. Refill reservoir as needed.

18. Operate system and check for leaks. Repair and replace components as necessary.

Cutting Edge

NOTE: Note: Cutting edge must be replaced when it is worn to the bottom edge of the frame.

1. Raise the plow to full up position.
2. Place blocking or a jackstand under front of A-frame.
3. Lower plow onto blocking or jackstand.
4. Remove mounting bolts holding old cutting edge to blade. Discard old cutting edge and hardware.
5. Consult parts manual for proper replacement cutting edge.
6. Install new cutting edge using new hardware.

Trip Spring Adjustment

See "Mechanical Installation" on page 5.

PLOWING OPERATION

Operating Class

The UTV series Sno-Way plow is specifically designed for applications on mid and full sized UTVs.

Before the Season Begins

1. Inspect plow vehicles brakes, headlights, electrical system, and cooling system for proper operation.
2. Inspect plow assembly including sub frame for any damage or excessive wear. Replace parts as necessary.
3. Inspect all fasteners to insure they are properly tightened. Re-tighten loose fasteners to the proper torque (Refer to torque specification chart in this manual).
4. Apply a small amount of light oil to: lower hitch pins, pivot pins between the upper and lower blade frame and pivot pins at lift and swing cylinders. Also lubricate trip spring mount pivots. (See Figure 2-1).
5. If wear is noticed between the A-frame and the swing frame apply a good quality anti-seize lubricant to this area.
6. Clean and repaint any exposed metal parts with corrosion resistant enamel.
7. Check free play between the a-frame and swing frame pivot. Adjust if necessary. (See "Break In Period" on page 9).
8. Check the oil level and repair any oil leaks. (See "THEORY OF OPERATION" on page 19).
9. Inspect electrical connectors. Make sure the contacts are clean, and apply a small amount of dielectric grease.
10. Install auxiliary and flashing lights (if not equipped). Ensure auxiliary lights are aimed properly (with the plow raised).
11. If ballast is required, position and secure ballast behind rear wheels, for optimum performance.

Transporting Vehicle With Plow Attached



CAUTION

Remove the plow when driving extended distances at temperatures above 40 deg. F, the plow blocks enough airflow to cause it to overheat at temperatures above 40 deg. F.

1. Position the blade out of the beam path of the headlights before driving.

2. Do not exceed 25 M.P.H. when driving with the snowplow attached. Braking distance is increased and handling impaired at speeds above 25 M.P.H.

3. Reduce speed when crossing railroad tracks or when conditions deteriorate.

4. Never change blade angle or height while driving.

5. Inspect plow and attaching hardware for damage before transporting or plowing.

Plowing Like A Pro



WARNING

Wear your seat belt! Contact with a hidden obstruction can cause serious personal injury from bodily contact within the vehicle cab or whiplash from sudden stops.

FAILURE TO FOLLOW CAN RESULT IN INJURY OR DEATH

NOTE: For better clean up of hard packed snow; raise the disc shoes if equipped so that the cutting edge of the blade comes into direct contact with pavement. Use the lowest possible gear to place maximum power behind the cutting edge.

For instructions on using the plow controller to manipulate the plow see the manual included with your plow control package.

1. Become familiar with the area to be plowed and mark potential hazards before the snow falls. Many immovable objects cannot be seen when covered with snow. Developing a plan early can save valuable time and equipment damage. Allow sufficient room to pile snow, out of the traffic area, with enough space for when the next storm comes.

2. Plow with the storm. The "Pros" are out early removing only several inches at a time. Allowing snow to accumulate to unmanageable levels can cause removal problems and wear and tear on equipment. The plow is not a "Ram" or a "Bulldozer". If used properly, it will give many years of safe and reliable service.

3. Research municipal ordinances for restrictions on the disposal of snow. Many municipalities do not allow snow to be placed in or moved across roads or highways.

Clearing Driveways

1. Head into driveway with the blade angled to move snow away from buildings. Continue to widen the drive path by rolling snow away from buildings on successive passes.

2. If there is a garage at the end of the driveway, plow to within several vehicle lengths of the garage and push the snow off the driveway.

3. Raise the blade and drive through the snow up to the garage. Drop the blade and "Back Drag" the snow 1-1/2 vehicle lengths back. Repeat as necessary.

4. Back the vehicle to garage door and plow forward toward street, removing the remaining snow.

Clearing Parking Lots



CAUTION

Excessive stacking of snow causes undue stress to the snowplow and vehicle. Repeated loading of this nature may result in the failure of plow components designed to protect the snowplow and vehicle from major damage.

1. "Back Drag" areas in front of buildings and near walls then work away from buildings towards the outer edges of the lot.

2. Plow a single path down the center in the longest direction.

3. Angle plow toward the outside and make successive passes until the area is cleared and the snow is "Stacked" around the outer edges. If snow is too deep to clear in the above manner, clear main traffic lanes and stack snow at intermediate positions.

TROUBLESHOOTING

Introduction

Whenever service is necessary, your local dealer knows your plow best and is interested in your complete satisfaction. Return your snowplow to your local dealer for maintenance service or any other assistance you may require. If you are unable to do so, this troubleshooting guide should help you determine the problem. However, before attempting the servicing of your plow, you should possess good mechanical abilities and a total understanding of the mechanism.

PLEASE: Before calling parts and service personnel be certain that:

1. You have read this guide carefully and are certain that all of the suggestions pertaining to your problem have been attempted.

2. You have the following available:

- A. Date snowplow was originally installed
- B. Power Pack Serial Number
- C. Controller Serial Number
- D. Blade Serial Number
- E. Pump Serial Number

This information should be recorded on page 2 of this Owners Manual.

Troubleshooting Quick Reference

- General

1. Check vehicle electrical system for proper operation.
2. Check all wiring to be sure that battery terminals are clean and connections to battery, solenoid, and all connectors on plow harness are clean and tight.
3. Check for external leakage at cylinders, hoses, and power unit.
4. Check the voltage at the coils which operate solenoid valves. For proper operation, ProControl system solenoid coils require a minimum of 10.5 volts DC.
5. Check oil level in hydraulic system reservoir.

TROUBLESHOOTING GUIDE

PROBLEM	PROBABLE CAUSE	CORRECTIVE ACTION
Motor will not run/ motor runs slow	Fuse Blown	Check the 10A fuse on the pump harness. If the fuse has blown check over all electrical wiring to determine why the fuse blew and replace fuse.
	Motor solenoid failed	Replace Motor solenoid.
	Motor seized	Remove and replace motor, torque motor bolts between 50 to 60 inch pounds.
	Motor brushes worn	Replace motor.
	Seal between motor and pump damaged allowing oil to enter motor housing	Remove the motor. Drain oil from the reservoir. Loosen the clamp and remove the reservoir. Remove the 4 Allen screws and remove the pump from the base block. Remove pump seal and replace. If the motor can be salvaged, clean out motor and reassemble. If the motor can not be salvaged replace motor.
Motor continues to run and will not shut off	Wires shorted out	Check all wires starting at solenoid working your way back to the vehicle.
	Solenoid shorted internally	Replace solenoid.
	Receiver shorted internally	Test the brown wire on the small post of the solenoid so see If the wire has a continuous ground without function. Replace receiver.

TROUBLESHOOTING GUIDE

PROBLEM	PROBABLE CAUSE	CORRECTIVE ACTION
Blade will not lift (motor Runs)	Hydraulic fluid level low	Fill hydraulic fluid up to the fill line on the reservoir using Sno-Way hydraulic fluid.
	Improper main system pressure relief valve setting	Using a 3000 psi gauge plumbed into the gauge port (GP), run plow over relief. Adjust main pressure relief screw to the proper main system pressure for the series of plow. This can be found in the back of your owners manual or online at SNOWAY.com.
	Breather cap plugged	Remove and replace breather cap.
	Coil on valve (A)	Check if there is magnetism on coil (A). If there is not, swap coil with the coil (B). If the problem moves to the Float function, the coil is bad and needs to be replaced.
	Raise valve (A) stuck	Remove and inspect (A) valve. If the valve is stuck closed, replace the valve.
	Raise cylinder binding	Inspect the cylinder, a-frame & lift bar. Replace any damaged components.
	Pick-up tube filter plugged	Remove hydraulic fluid from the tank. Remove the tank and observe the pick-up tube screen. Clean or replace if necessary.
	Worn/failed pump	Using a 3000 psi gauge plumbed into the gauge port (GP), run plow over relief. Adjust main pressure relief screw. If the pressure will not raise and the angle functions work, remove hydraulic fluid and tank. Replace pump.
	Pick-up tube is not submerged in fluid	Remove hydraulic fluid and tank. Turn pick-up tube so it is angled down to the bottom of the tank.
Blade angles when raise function is activated	Ground available at coil (C) during raise function	Test the control receiver to see if there is a ground signal sent to coil (C) during raise function. Remove the green wire from the coil (C). If problem goes away, the receiver (black/yellow box on snow plow) will need to be replaced. To confirm that the receiver needs to be replaced, use a Sno-Way control test box (99101028).
	Valve (C) not functioning correctly	Remove the "C" valve and inspect. Make sure the lower part of the valve moves free and there is no debris causing the valve to stick. If stuck and can't be freed up, replace valve.
Blade lifts slowly	Hydraulic fluid level low	Fill hydraulic fluid up to the fill line on the reservoir using Sno-Way hydraulic fluid.
	Breather cap plugged	Remove and replace breather cap.
	Improper main system pressure relief valve setting	Using a 3000 psi gauge plumbed into the gauge port (GP), run plow over relief. Adjust main pressure relief screw to the proper main system pressure for the series of plow. This can be found in the back of your owners manual or online at SNOWAY.com.
	Pick up tube filter plugged	Remove hydraulic fluid from the tank. Remove the tank and observe the pick up tube screen. Clean or replace if necessary.
	Improper oil viscosity for outside air temperature/ Ice in hydraulic tank	Change oil with Sno-Way hydraulic fluid.
	Weak system pump	Using a 3000 psi gauge plumbed into the gauge port (GP), run plow over relief. Adjust main pressure relief screw. If the pressure will not raise and the angle functions work, remove hydraulic fluid and tank. Replace pump.
	(continued)	

TROUBLESHOOTING GUIDE

PROBLEM	PROBABLE CAUSE	CORRECTIVE ACTION
Blade lifts slowly (continuation)	Low vehicle battery voltage	Check voltage at both the battery and at the solenoid during function. The battery may show 12V when the plow is not under load. If the voltage drops below 9V when operating the plow, trouble shoot power system on your vehicle.
Plow lifts but does not hold - New plow first action	Dirt in lower valve (B)	Cycle raise and lower system to unstick valve.
Plow lifts but does not hold - second action	Lower valve (B) stuck	Check valve to make sure there is not magnetism on the "B" coil. Remove the "B" valve and swap it with the "F" valve. If the blade lifts your valve was stuck open. Replace the valve.
	Seals, O-ring(s) on lower valve (B) damaged	Remove the lower valve (B) and inspect the O-rings to see if they are damaged. If damaged replace the O-ring if there is one available. If not replace the valve.
	Ground available at lower coil (B) without activation	Test the control receiver to see if there is a ground signal sent to the lower coil (B) without activation. This can be done using a Sno-Way control test box (99101028). If you do not have a test box, remove the two wires off of the (B) coil and check to see if the blue with the white trace wire has a ground signal coming from it. The control will need to be turned on. Tap the raise function to make sure the control is not in the float or down pressure mode as this would send the ground signal to the wire. If the ground is present the receiver (black/yellow box on snow plow) will need to be replaced. You should also check the OHM reading on the (B) coil as well as the other coils on the valve block. If the OHM reading on the (B) coil does not read the same as the other coils replace the coil as well.
	Piston seals leaking on raise cylinder	Raise the plow up in the air and support the blade with a hydraulic floor jack. Remove the hose off of the base side of the lift cylinder. Slowly lower the floor jack and watch to see what direction the fluid flows from the lift cylinder. If the fluid sucks into the lift cylinder the seals are good. If the fluid flows out of the lift cylinder fluid is leaking past the seals and the cylinder needs to be replaced.
Unit will not lower	Plugged breather cap	Remove and replace breather cap.
	Low or no current available at lower coil (B)	Check wiring harness to make sure the connection had not been severed. If a ground is present when operated from the blue with the white trace wire the coil may be weak. Swap coil with another coil on the valve block. If the problem moves to a different function, replace coil.
	Lower valve (B) sticking or stuck	Remove and inspect valve (B). If it does not actuate, replace the valve.
	Lower coil (B) inoperative	Check to see if the blue with the white trace wire has a ground signal. If it does and the coil is not magnetized, the coil needs to be replaced.
	Raise cylinder damaged allowing movement in one direction only	Visually inspect lift cylinder. If it is damaged replace lift cylinder.
Blade will not angle either direction (motor runs)	Hydraulic fluid level low	Fill hydraulic fluid up to the line on the reservoir using Sno-Way hydraulic fluid.
	(continued)	

TROUBLESHOOTING GUIDE

PROBLEM	PROBABLE CAUSE	CORRECTIVE ACTION
Blade will not angle either direction (motor runs) (continuation)	Angle cylinder binding or bent	Visually inspect cylinder, If it is damaged, replace cylinder.
	Pick-up tube not submerged in fluid	Add fluid to the fill line. See Maintenance section of owners manual.
	Crossover relief valve sticking or stuck	Remove crossover relief valve and inspect. Clean if possible or replace crossover relief valve.
Unit angles very slowly	Hydraulic fluid level low	Fill hydraulic fluid up to the line on the reservoir using Sno-Way hydraulic fluid.
	Pivot bolt too tight clamping a-frame to blade frame	Loosen pivot bolt slightly to free up blade frame movement
	Improper oil viscosity for outside air temperature/ Ice in hydraulic tank	This will effect all functions. Replace hydraulic fluid with Sno-Way hydraulic fluid.
	Damaged cylinder	Visually inspect cylinder. If it is damaged, replace cylinder.
	Crossover relief valve pressure setting too low	All other problems should be addressed before moving to the cross over relief valve. If the cross over relief valve is not set properly, you will also notice the plow not holding angle when plowing. If this is the case, replace crossover relief valve.
Unit does not hold angle. Note: This problem is usually noted when pushing snow.	Crossover relief valve pressure setting too low, sticking or stuck	Replace crossover relief valve.
	Pilot check valve has debris or damaged piston	Remove pilot check valve and inspect cartridges. If the valve has external springs make sure they both are not damaged and installed properly. Clean valves and reinstall.
Fluid leaking at power unit	Hydraulic fittings not torqued properly (too tight, too loose)	Inspect fitting and tighten if too loose. If too tight, inspect hose fitting for cracks. Check O-rings on fittings on valve block to see if they are damaged. Replace hoses or O-ring if they are available.
	O-rings between base and the reservoir worn or not seating properly	Drain the oil out of the reservoir. Remove the tank. Inspect the O-ring on the base block. If it is damaged or not seated properly, reseal or replace the O-ring.
	Reservoir over-full	Oil will leak out of the breather cap if this is the problem. Remove hydraulic fluid down to the fill line on the reservoir.
	Pump shaft seal leaking	This can be determined if there is oil leaking from the motor housing. Remove the motor. Drain the oil out of the reservoir and remove. Remove the pump from the base. Remove the pump seal. Install new seal. Reinstall all components removed.
	Reservoir fasteners loose	Tighten reservoir fastener or replace if damaged.
Blade angles right during left function	Coil (A) inoperative	Check for magnetism. If there is no magnetism, switch coil (A) with coil (B). If left angle works, replace coil.
	Valve (A) stuck closed	Remove and inspect valve (A). If it can not be cleaned and actuated, replace valve.

TROUBLESHOOTING GUIDE

PROBLEM	PROBABLE CAUSE	CORRECTIVE ACTION
Blade raise during left function	Coil (C) inoperative	Check for magnetism. If there is no magnetism, switch coil (C) with coil (B). If left angle works, replace coil.
	Valve (C) stuck closed	Remove and inspect valve (C). If it can not be cleaned and actuated, replace valve.
Nothing happens during left function (motor runs)	Pilot Check Cartridge failure	Replace pilot check cartridge.
Blade angles left during right function	Valve (A) stuck open	Remove and inspect valve (A). If it can not be cleaned and actuated, replace valve.
Nothing happens during right function (motor runs)	Coil (C) inoperative	Check for magnetism. If there is no magnetism, switch coil (C) with coil (B). If left angle works, replace coil.
	Valve (C) stuck closed	Remove and inspect valve (C). If it can not be cleaned and actuated, replace valve.

THEORY OF OPERATION

Hydraulic Power Unit

The hydraulic power unit consists of:

- 12V DC Motor
- Hydraulic pump rated at 0.89 GPM @ 1250 PSI
- 0.6 quart capacity reservoir
- Fine mesh intake filter

The fluid supply line for the pump is submerged in the hydraulic fluid reservoir and is equipped with a fine mesh intake filter screen.

The hydraulic pump is protected by a 1250 PSI system relief valve.

IMPORTANT: For proper operation, ProControl system solenoid coils require a minimum of 10.5 volts DC. Lower voltage will cause erratic operation, or failure to operate.

Hydraulic Controls

The hydraulic controls consist of:

- System pressure relief valve set to 1250 PSI.
- One crossover relief valve set to 1800 PSI.
- One four way two position hydraulic valve for angle and lift functions.
- Two single acting hydraulic cylinders for angle left and right functions.
- One three-way two position hydraulic valve for angle functions.
- One two way two position valve for lower and float functions.

Electro-Hydraulic Operation

All hydraulic functions are controlled by the 12V DC electrical system which energize coils on the hydraulic valve and the power unit motor start solenoid.

ProControl and ProControl II systems (Figure 3-2) directly apply +12V DC power to all valve coils as soon as power is connected to the plow.

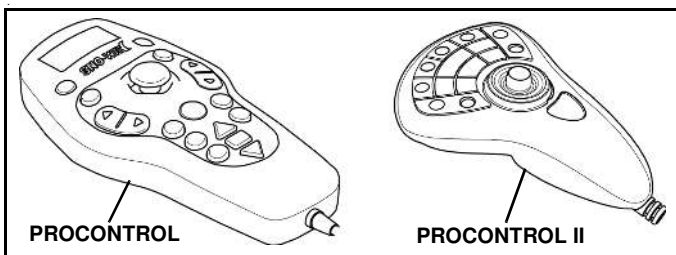

Figure 3-2

The system employs ground switching to energize the hydraulic valve coils. The individual coils are energized as required when the control circuit board or receiver module completes the coil circuit path to ground by means of a signal from the wired or wireless hand-held controller in the vehicle.

Raise Mode Of Operation

Actuating the 'Raise' switch on the hand-held controller sends a signal to the control circuit board on the plow, which then actuates the motor start solenoid and the coil for the 'A' valve.

Actuating the start solenoid sends current to the power unit motor to cause the power unit to pump hydraulic fluid. Hydraulic fluid under pressure is directed through the 'A', 'C' and 'B' valves (only valve 'A' is actuated) to the lift cylinder causing it to retract and raise the plow. The base end of the lift cylinder is vented back to the reservoir to allow air/oil to escape as the cylinder retracts.

When the 'Raise' switch on the hand-held controller is released, the start solenoid circuit is broken, the motor stops, the circuit to the coil for the 'A' valve is broken and the valve goes to its normal position.

Lower Mode Of Operation - Gravity Down and Float

Actuating the 'Lower' switch on the hand-held controller sends a signal to the control circuit board on the plow. This actuates the coil for the 'B' valve allowing hydraulic fluid to flow from the lift cylinder to the reservoir.

Once the 'Lower' switch has been actuated, the system will stay in this mode until the 'Raise' function is actuated or control is shut off, allowing hydraulic fluid to flow between the reservoir and the lift cylinder. This allows the lift cylinder to extend and retract as necessary to follow ground contours while plowing.

Angle Left or Right Mode of Operation

Actuating the 'Angle Right' switch on the hand-held controller sends a signal to the control circuit board on the plow. This actuates the start solenoid which pumps oil thru the 'A' valve (not shifted) to the swing cylinder. The 'C' valve is also actuated to allow oil from the opposite cylinder to return to the reservoir.

Actuating the 'Angle Left' switch on the hand-held controller sends a signal to the control circuit board on the plow. This actuates the start solenoid and the coil for the 'A' and 'C' valves, allowing hydraulic fluid under pressure to flow to the swing cylinder. This fluid also unseats a check valve allowing fluid to flow from the opposite swing cylinder through the 'A' valve and back to the reservoir.

The angle circuits are protected by a crossover relief valve set to relieve pressure on the circuit at 1800 PSI. If the blade of the plow contacts an obstacle during plowing operations, the crossover relief valves will allow fluid to flow out of the swing cylinder on the side encountering the obstacle, allowing the cylinder to retract and allowing the blade to adjust its angle to relieve the force from the outside.

HYDRAULIC SCHEMATIC

Gravity Down System

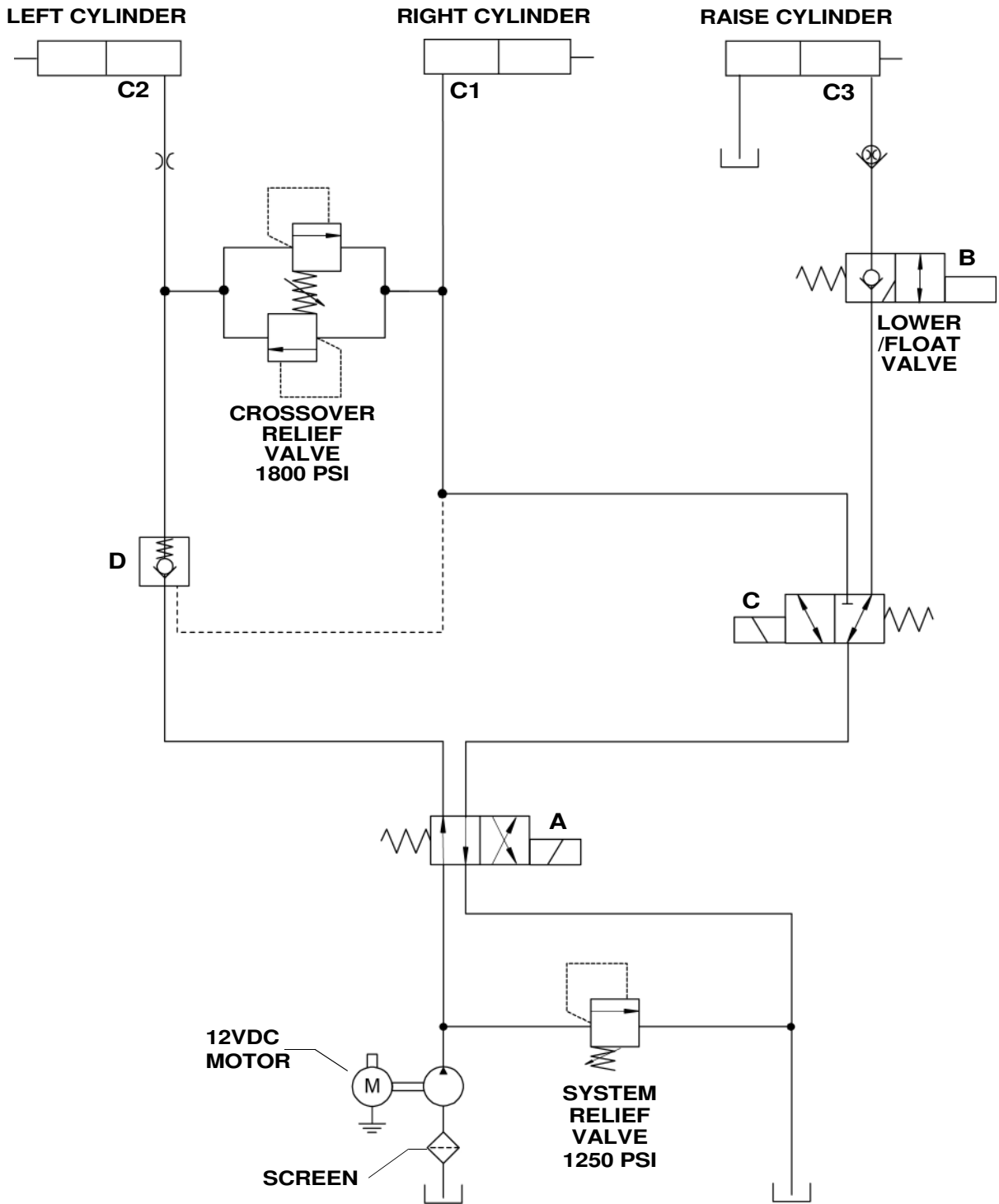

WIRING SCHEMATIC



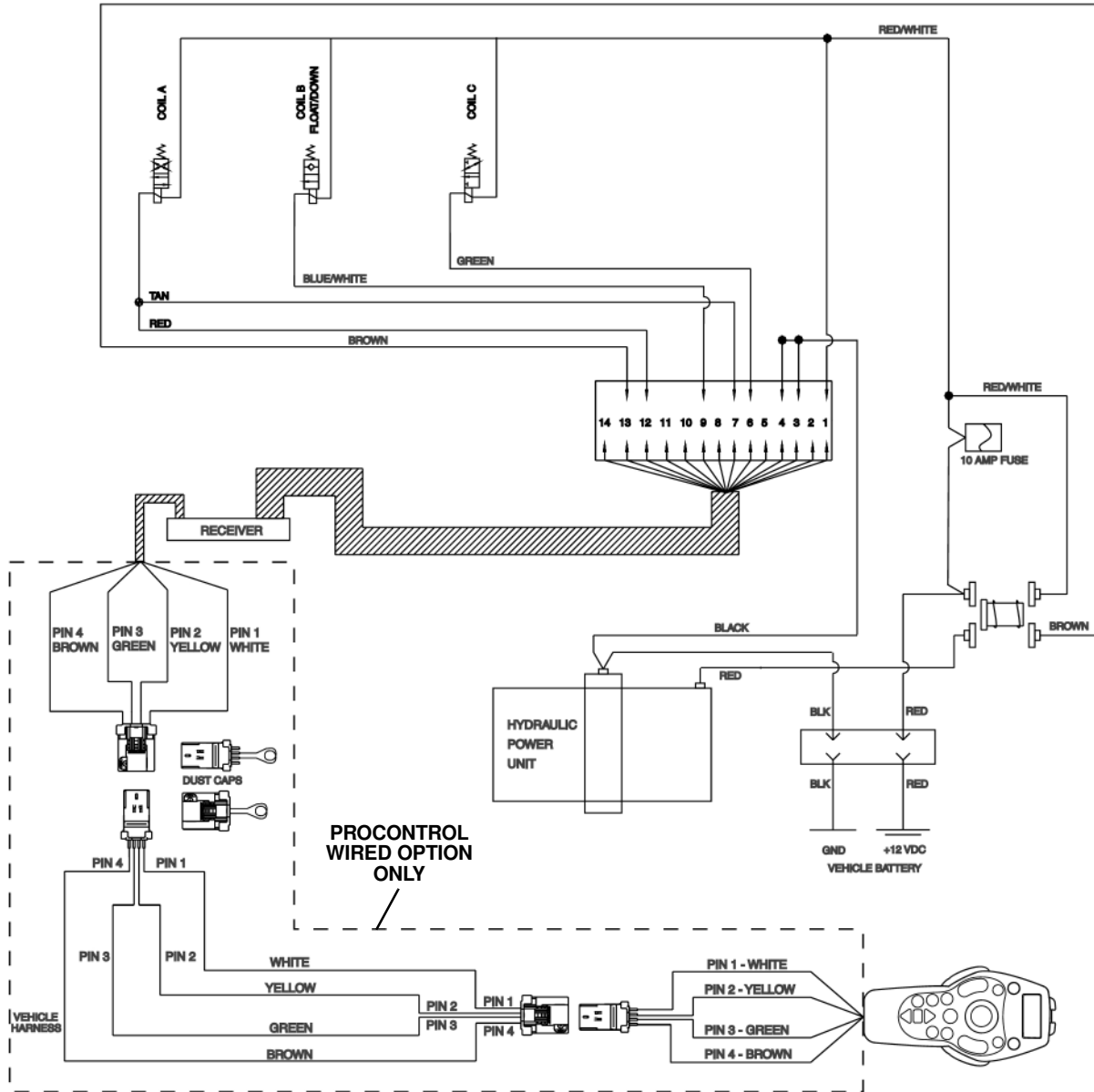

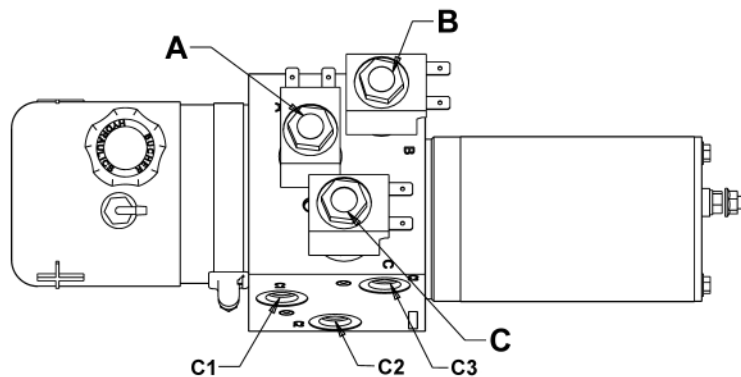

Gravity Down System



PLOW FUNCTION	MOTOR SOLENOID	A	B	C
WIRE COLOR	BROWN	RED/TAN	BLUE/WHITE	GREEN
RAISE	X	X		
DOWN (FLOAT)			X	
ANGLE LEFT	X	X		X
ANGLE RIGHT	X			X

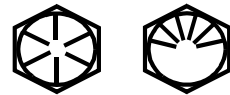

TORQUE SPECIFICATIONS

SAE Grade and Head Markings	1 or 2 No Marks 	5 5.1 5.2 	8 8.2 
SAE Grade and Nut Markings	2 No Marks 	5 	8 

	Grade 1		Grade 2		Grade 5, 5.1 or 5.2		Grade 8 or 8.2	
	Lubricated ^a	Dry ^b	Lubricated ^a	Dry ^b	Lubricated ^a	Dry ^b	Lubricated ^a	Dry ^b
SIZE	lb-ft	lb-ft	lb-ft	lb-ft	lb-ft	lb-ft	lb-ft	lb-ft
8-32			14*	19*	22*	30*	31*	42*
10-24			21*	27*	32*	43*	45*	60*
1/4	2.8	3.5	4.5	5.5	7	9	10	12.5
5/16	5.5	7	9	11	15	18	21	26
3/8	10	13	16	20	26	33	36	46
7/16	16	20	26	32	41	52	58	75
1/2	25	31	39	50	63	80	90	115
9/16	36	45	56	70	90	115	130	160
5/8	50	62	78	100	125	160	160	225
3/4	87	110	140	175	225	280	310	400
7/8	140	175	140	175	360	450	500	650
1	210	270	210	270	540	675	750	975
METRIC COARSE THREAD			Grade 8.8		Grade 10.9		Grade 12.9	
Grade 8.8			Dry	Lubed	Dry	Lubed	Dry	Lubed
M6-1			8	6	11	8	13.5	10
M8-1.25			19	14	27	20	32.5	24
M10-1.5			37.5	28	53	39	64	47
M12-1.75			65	48	91.5	67.5	111.5	82
M14-2			103.5	76.5	145.5	108	176.5	131
M16-2			158.5	117.5	223.5	165.5	271	200

DO NOT use these values if a different torque value or tightening procedure is given for a specific application.

Fasteners should be replaced with the same or higher grade. If higher grade fasteners are used, these should only be tightened to the strength of the original.

^a "Lubricated" means coated with a lubricant such as engine oil, or fasteners with phosphate and oil coatings.

^b "Dry" means plain or zinc plated without any lubrication

* Values with asterisk are in lb-in.

NOTES

NOTES

SNO-WAY[®] INTERNATIONAL, INC.

SNO-WAY[®]
SNOW & ICE CONTROL EQUIPMENT

Hartford, WI 53027 USA
Website: www.snoway.com
©2015 Sno-Way[®] International

DEALER PRE DELIVERY CHECKLIST

The following inspections **MUST** be accomplished prior to delivering the snowplow to the customer. Place an X in the box after accomplishing each item on the checklist.

CHECK THAT

- Parts have not been damaged in shipment. Repair or replace items that are loose, dented or missing.
- All covers, guards and decals are in place and attached securely.
- All pivot pins and cotters are installed and secure.
- Trip springs are adjusted.
- Shoe assemblies are installed and adjusted.

Start the vehicle engine and place an X in the box after accomplishing each item on the checklist.

CHECK THAT

- ALL** blade functions work properly.
- Cylinders, hoses and fittings **DO NOT** leak.
- Listen for abnormal noises or vibrations; Repair or replace as necessary.
- The Power Unit is properly filled.

DELIVERY CHECKLIST

The following checklist is to be accomplished with the customer present, Place an X in the box after accomplishing each item on the checklist.

- After giving the Customer his Owner's Manual, instruct him to read it **PRIOR** to operating the Snow Plow. If he has any questions or does not understand part(s) of the Manual, ask him to contact the Dealer for answers or explanations **BEFORE** operating the unit.
- Record the Serial Numbers, Date of Purchase, Purchaser's Name and Address, and the Dealers Name, Address and Phone Number in the space provided on Page 1 of the Owner's Manual.
- Explain mounting and removal procedures.
- Demonstrate power plow controller operation.
- Fill out Warranty Registration Card and mail COPY 1 to the factory to validate Warranty. NO Warranty claims can be honored if the Warranty Card is not on file at the factory.**

SNO-WAY® INTERNATIONAL, INC.

SNO-WAY
SNOW & ICE CONTROL EQUIPMENT

Hartford, WI 53027 USA
Website: www.snoway.com
©2015 Sno-Way® International