

SNO-WAY[®]

SNOW & ICE CONTROL EQUIPMENT

Assembly & Installation Instructions

**FOR
VEHICLE MOUNT KIT 99100877
(Includes Vehicle Center Member)**

**TO FIT
1997 & LATER JEEP WRANGLER 4x4
2003-2006 JEEP RUBICON AND UNLIMITED 4x4**

22 SERIES PLOW ONLY



1. **THINK SAFETY, ALWAYS WEAR SAFETY GLASSES WHEN PERFORMING THE OPERATIONS PRESCRIBED IN THESE INSTRUCTIONS**
2. **READ ALL INSTRUCTIONS CAREFULLY BEFORE ATTEMPTING INSTALLATION**
3. **BEFORE BEGINNING WORK MAKE SURE TO SET PARKING BRAKE AND CHOCK WHEELS**



MINIMUM VEHICLE RECOMMENDATIONS

Heavy Duty Alternator
 Heavy Duty Battery
 Heavy Duty Suspension

NOTE: On some vehicles it may be necessary to use a form of load booster to decrease the vehicle's front suspension sag with the snow plow in place. This can be accomplished with the use of supplementary air bags, booster springs, or similar load boosting devices. Since there are different load boosting devices available, it will up to the customer/end user to decide and purchase the product to suit the application, and not the responsibility of Sno-Way International, Inc.

ASSEMBLY TOOLS NEEDED

Sockets	7/16" – 1-1/8"
Wrenches	7/16" – 1-1/8"
Torque Wrench	
Clamps	
Drill Bit	17/32"

INSTALLATION NOTES

1. **Unless otherwise specified, mount all Vehicle Mount Kit Components to vehicle before tightening any hardware.**
2. **It is recommended that LOCTITE®, or similar thread locking product, be used on ALL mounting hardware (i.e. Nuts, Cap Screws, Bolts, etc.).**
3. Vehicle should be parked on a level surface with a normal vehicle load on the FRONT suspension.
4. Items in parentheses () refer to quantity required for this step. Items in parentheses with a pound sign (#) indicate the part number as found in the parts list on the last page of this document.
 Example: (10) 1/2"-13 Nylock Nut (#7).
5. It maybe necessary to relocate license plate holder. Check state and local laws for placement, if needed.

- and (1) 1/2" Flat Washer (#11), through the slots of the frame rail into the just-drilled rear side hole. Insert (1) Handle Bolt Weldment (#4), and (1) 1/2" Flat Washer (#11), through the slots of the frame rail into the just drilled front side hole.
- It may be necessary to bend the handles welded to the bolts to reach the drilled holes. Secure Handle Bolt Weldments with (2) 1/2" Nylock Nuts (9).
5. Repeat steps 2-4 to install the Mounting Weldment, RH (#3). (No spacer (#5) is needed to install the Mounting Weldment, RH.)
 6. Assemble the Vehicle Center Member (#1), to the Mounting Weldments, LH (#2) and RH (#3). Secure using (8) 1/2"-13 x 1-1/2" Cap Screws (#7), (2) 1/2" Lock Washers (#8) in the threaded holes, and (6) 1/2" Nylock Nuts (#9).
 7. Keeping the Vehicle Center Member parallel to ground, tighten all fasteners using the Torque Specification Chart provided.

MOUNTING INSTRUCTIONS

1. Remove bumper bolts securing the bottom edge of the bumper to the vehicle frame.
2. Position Mounting Weldment, LH (#2), so that the bottom front mounting hole aligns with the mounting holes where the left side bumper bolt was removed. Secure loosely using (1) 1/2"-13 x 1-3/4" Cap Screw (#10), (1) 1/2" Lock Washer (#8), and (1) 1/2" Flat Washer (#11), inserted through the Mounting Weldment, LH, and bumper, into the vehicle frame.
3. Insert Spacer (#5) between the Mounting Weldment, LH (#2), and the vehicle frame, aligned with the front side mounting hole. Clamp rear portion of the Mounting Weldment to the frame rails.
 Using the two side mounting holes in the rear portion of the Mounting Weldment as a template, drill (2) 17/32" holes through the outer frame rail.
4. Loosely secure the rear portion of the Mounting Weldment by inserting (1) Handle Bolt Weldment (#6),

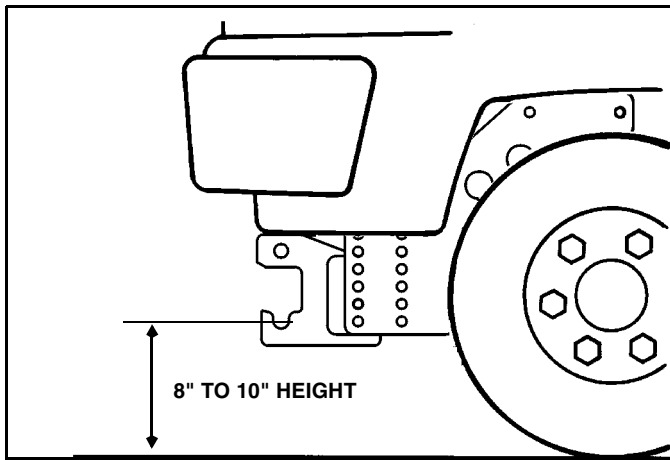

IMPORTANT: Height from the center of the lower pin slots on the Vehicle Mount Kit to the ground should be between 8" and 10" to insure proper operation. On some vehicles, it may be necessary to use a form of load booster (See NOTE on page 1, Minimum Vehicle Recommendations).

TORQUE SPECIFICATIONS FOR STANDARD MACHINE HARDWARE					
Bolt Size	GR.2 Dry	GR.5 Dry	GR.8 Dry	Metric Size	GR.8.8 Dry
1/4"	66*	9	12	M8	17
5/16"	11	17	25	M10	35
3/8"	20	30	45	M12	60
7/16"	32	50	70	M14	95
1/2"	50	75	110	M16	155
9/16"	70	110	150		
5/8"	100	150	220		
3/4"	175	260	380		
7/8"	170	430	600		
1"	250	640	900		

Note: These torque values are to be used for all hardware. Unless otherwise specified, all torque values must meet this specification.
 Note: All torque values are in Ft.-Lbs unless otherwise stated
 Note: *In-Lbs

REMEMBER After 5 to 10 hours of snowplow usage, re-torque all Cap Screws!

PARTS LIST

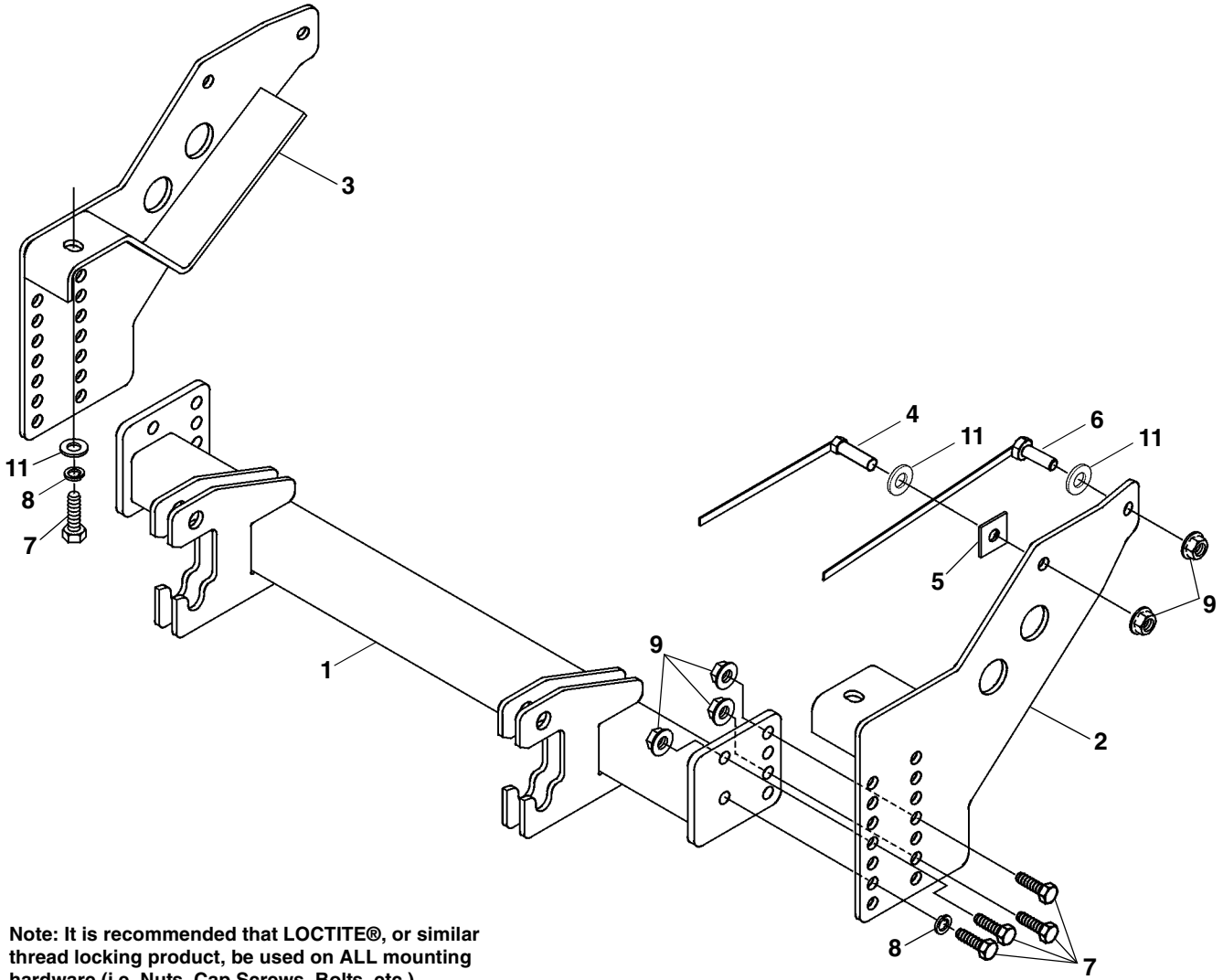

Note: It is recommended that LOCTITE®, or similar thread locking product, be used on ALL mounting hardware (i.e. Nuts, Cap Screws, Bolts, etc.).

ITEM	PART NO.	DESCRIPTION	QTY.
1		Vehicle Center Member.....	1
2		Mounting Weldment, LH.....	1
3		Mounting Weldment, RH.....	1
4		Handle Bolt Weldment (1/2"-13 x 1-1/2" bolt).....	2
5		Spacer.....	1
6		Handle Bolt Weldment (1/2"-13 x 1-1/4" bolt).....	2
7		Cap Screw, Hex Head, 1/2"-13 x 1-1/2".....	8
8		Washer, Lock, 1/2".....	4
9		Nut, Nylock, 1/2"-13.....	10
10		Cap Screw, Hex Head, 1/2"-13 x 1-3/4".....	2
11		Washer, Flat, 1/2".....	6
12	96108071	Kit, HDWE (Includes Items 7-11) (Not Shown).....	1

SNO-WAY® INTERNATIONAL, INC.



Hartford, WI 53027 USA
 Website: www.snoway.com
 ©2012 Sno-Way® International