



# **Assembly & Installation Instructions**

**FOR  
SUBFRAME COMPONENTS PACKAGE 99100527  
AND  
SUBFRAME NOSE PIECE PACKAGE 96105841  
TO FIT**

**1973-1987 Chevrolet & GMC 4x4 1500, 2500, and 3500 Pickup  
1973-1991 Chevrolet 4x4 1500 Blazer, 1500 Suburban, and 2500 Suburban  
1973-1991 GMC 4x4 1500 Jimmy, 1500 Suburban, and 2500 Suburban**



1. **THINK SAFETY, ALWAYS WEAR SAFETY GLASSES WHEN PERFORMING THE OPERATIONS PRESCRIBED IN THESE INSTRUCTIONS**
2. **READ ALL INSTRUCTIONS CAREFULLY BEFORE ATTEMPTING INSTALLATION**
3. **BEFORE BEGINNING WORK MAKE SURE TO SET PARKING BRAKE AND CHOCK WHEELS**



### MINIMUM VEHICLE RECOMMENDATIONS

Heavy Duty Alternator                      Heavy Duty Battery  
 Heavy Duty Front Springs

### ASSEMBLY TOOLS NEEDED

Drill Bits    1/4", 17/32"  
 Impact Sockets                                    7/16" – 1-3/8"  
 Wrenches    7/16" – 1-3/8"  
 Torque Wrench  
 Hammer & Center Punch  
 C-Clamps

*NOTE: On some vehicles it may be necessary to use a form of load booster to decrease the vehicle's front suspension sag with the snow plow in place. This can be accomplished with the use of supplementary air bags, booster springs, or similar load boosting devices. Since there are different load boosting devices available, it will up to the customer/end user to decide and purchase the product to suit the application, and not the responsibility of Sno-Way International, Inc.*

### INSTALLATION NOTES

1. **Unless otherwise specified, mount all Sub-Frame Components to vehicle before tightening any hardware.**
2. **It is recommended that LOCTITE®, or similar thread locking product, be used on ALL mounting hardware (i.e. Nuts, Cap Screws, Bolts, etc.).**
3. Vehicle should be parked on a level surface with a normal vehicle load on the FRONT suspension.
4. Items in parentheses ( ) refer to quantity required for this step. Items in parentheses with a pound sign (#) indicate the part number as found in the parts list on the last page of this document.  
 Example: (2) 5/8" x 1-1/2" Cap Screws (#10).
5. It maybe necessary to relocate license plate holder. Relocate under the driver's side headlight by drilling new holes in the bumper. Check state and local laws for placement, if needed.

3. Bolt (1) Mounting Assembly (#1) to the Right and Left Bracket Assemblies, using (4) 5/8" x 1-1/2" Cap Screws (#7) and (4) 5/8" Lock Washers (#8).
4. Install the Right and Left Support Assemblies (#2 & #3). Loosely attach to the Mounting Assembly using on each side (2) 1/2" x 1-1/2" Cap Screws (#9) and (2) 1/2" Nylock Nuts (#10).
5. Using the holes in the Right and Left Support Assemblies (#2 & #3) as a template, drill a 1/4" hole, then 17/32" hole through the vehicle frame. Secure on each side by using (2) 1/2" x 2" Cap Screws (#12), (2) 1/2" Flat Washers (#11), and (2) 1/2" Nylock Nuts (#10).
6. Using the torque specification chart, torque all cap screws.

### MOUNTING INSTRUCTIONS

1. Remove air dam from vehicle, retain with mounting hardware for future use if plow is removed.
2. Remove the tow hooks, if present. Remove the bolts securing the diagonal bumper brace to the frame. Position the Bracket Assemblies RH & LH (#4 & #5) to the front frame rails of the truck. With the assemblies insert (2) Spacer Plates (#6) on each side, between the frame and the Bracket Assemblies. For each side use (3) 1/2" x 3 Cap Screws (#13), (3) 1/2" Flat Washers (#11), and (3) 1/2" Nylock Nuts (#10) to secure the Bracket Assemblies and the tow hooks in place in front. The existing top bolt in each tow hook is reused. The tow hooks must be swapped left to right and right to left on the truck.

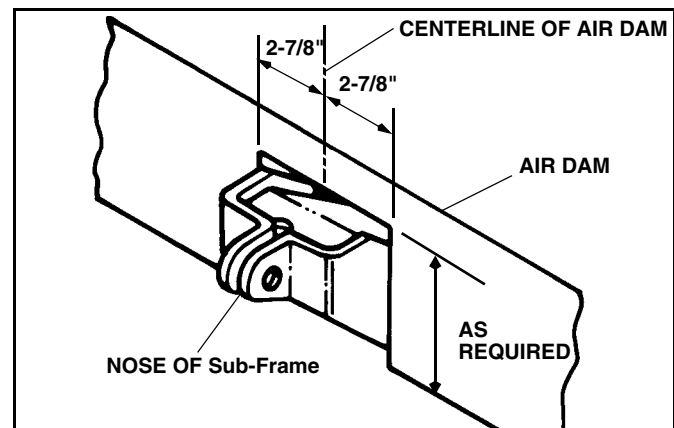

*NOTE: Air Dam may be used with Plow by cutting Dam to allow clearance for nose of Sub-Frame. To modify air dam, measure 2 7/8" from each side of center and remove a 5-3/4" deep section from between the marked areas.*



# CAUTION

**Beware of brake and fuel lines secured to inside wall of frame rails when performing Step 5.**

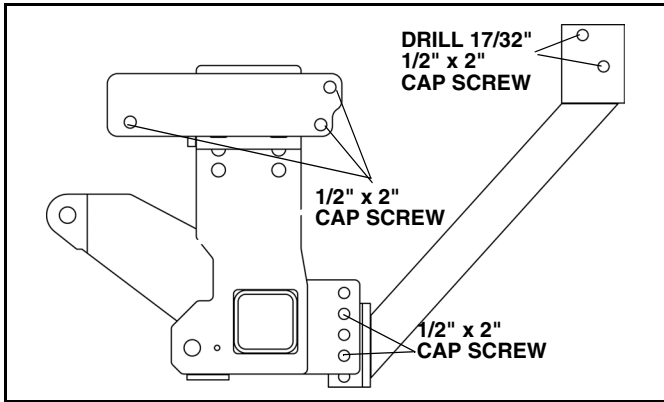

**NOTE:** When mounted in place the Sub-Frame must be level with the ground.

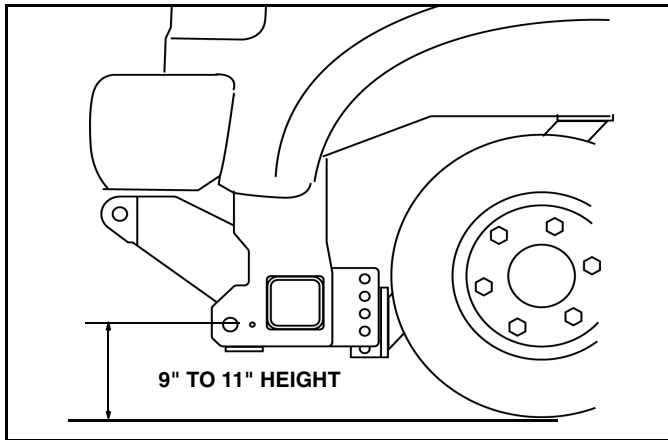

**IMPORTANT:** Height from the center of the lower Plow Mounting holes on the Sub-Frame to the ground should be between 9" and 11" to insure proper operation.

## TORQUE SPECIFICATIONS FOR STANDARD MACHINE HARDWARE

Bolt Size	GR.2 Dry	GR.5 Dry	GR.8 Dry	Metric Size	GR.8.8 Dry
1/4"	66*	9	12	M8	17
5/16"	11	17	25	M10	35
3/8"	20	30	45	M12	60
7/16"	32	50	70	M14	95
1/2"	50	75	110	M16	155
9/16"	70	110	150		
5/8"	100	150	220		
3/4"	175	260	380		
7/8"	170	430	600		
1"	250	640	900		

Note: These torque values are to be used for all hardware. Unless otherwise specified, all torque values must meet this specification.  
Note: All torque values are in Ft.-Lbs unless otherwise stated  
Note: \*In-Lbs

**REMEMBER** After 5 to 10 hours of snowplow usage, re-torque all Cap Screws!

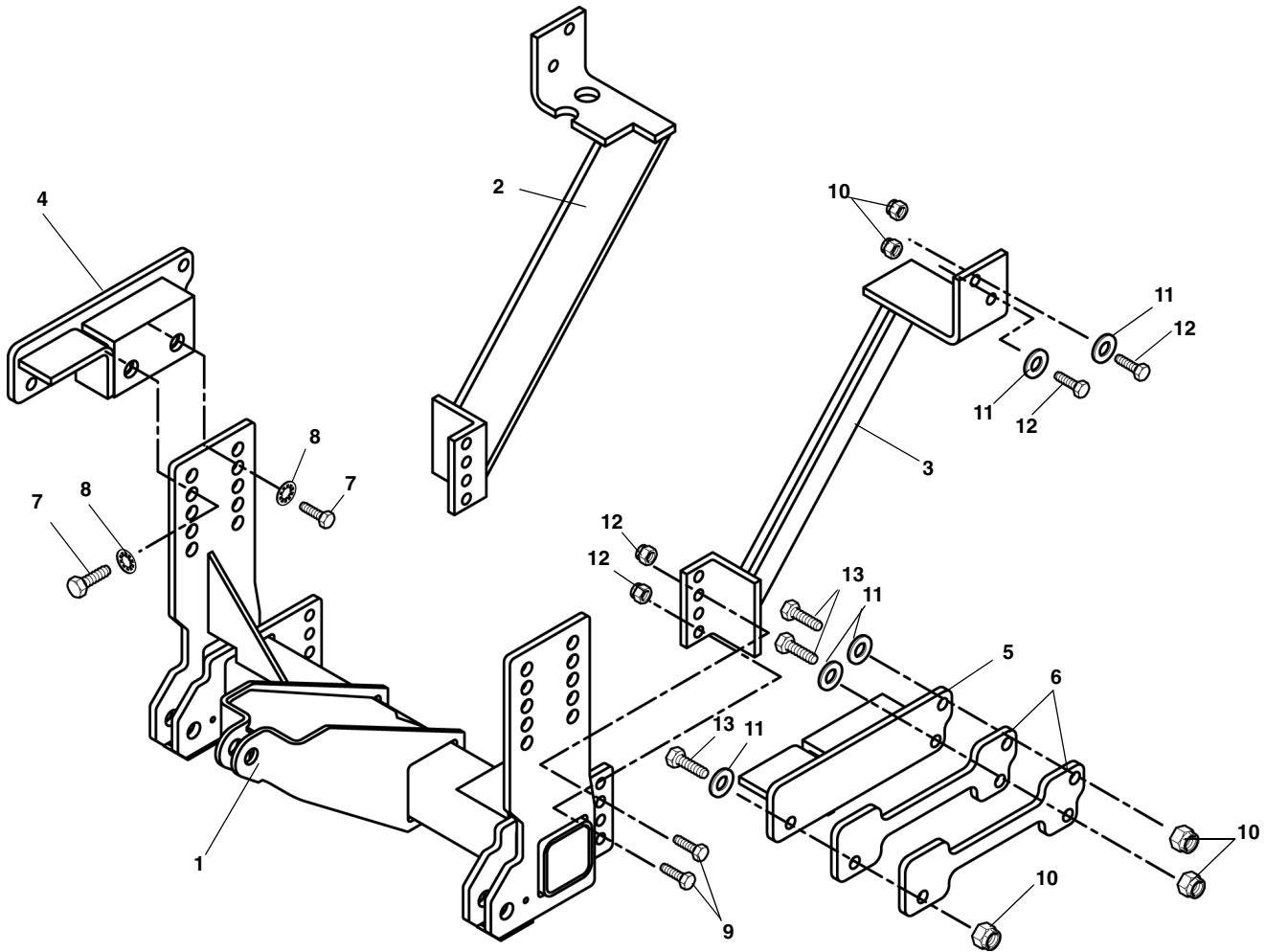

ITEM	PART NO.	DESCRIPTION	QTY.
1	96105841	Mounting Assembly .....	1
2	96105975	Right Support Assembly .....	1
3	96105972	Left Support Assembly .....	1
4	96105949	Right Bracket Assembly .....	1
5	96105950	Left Bracket Assembly .....	1
6	96106030	Spacer Plate .....	4
7	98009115	Hex Head Cap Screw, 5/8" - 11 x 1-1/2" .....	4
8	98009062	Lock Washer, 5/8" .....	4
9	98009010	Hex Head Cap Screw, 1/2" - 13 x 1-1/2" .....	4
10	98009013	Nylock Hex Nut, 1/2" - 13 .....	14
11	98009011	Flat Washer, 1/2" .....	10
12	98100094	Hex Head Cap Screw, 1/2" - 13 x 2" .....	4
13	98009017	Hex Head Cap Screw, 1/2" - 13 x 3" .....	6

SNO-WAY® INTERNATIONAL, INC.



844 West State Street  
 Hartford, WI 53027 USA  
 Phone (262) 673-7200  
 Fax (262) 673-7409  
 ©1999 Sno-Way® International