



**Assembly  
&  
Installation Instructions**  
**FOR**  
**SUBFRAME COMPONENTS PACKAGE 99100761**

**TO FIT**  
**2000- LATER TOYOTA TUNDRA PICKUP**



1. THINK SAFETY, ALWAYS WEAR SAFETY GLASSES WHEN PERFORMING THE OPERATIONS PRESCRIBED IN THESE INSTRUCTIONS
2. READ ALL INSTRUCTIONS CAREFULLY BEFORE ATTEMPTING INSTALLATION
3. BEFORE BEGINNING WORK MAKE SURE TO SET PARKING BRAKE AND CHOCK WHEELS



### MINIMUM VEHICLE RECOMMENDATIONS

Heavy Duty Alternator                      Heavy Duty Battery  
 Manufacturers Snow Plow Package

*NOTE: On some vehicles it may be necessary to use a form of load booster to decrease the vehicle's front suspension sag with the snow plow in place. This can be accomplished with the use of supplementary air bags, booster springs, or similar load boosting devices. Since there are different load boosting devices available, it will up to the customer/end user to decide and purchase the product to suit the application, and not the responsibility of Sno-Way International, Inc.*

### ASSEMBLY TOOLS NEEDED

Drill Bits    1/4", 17/32"  
 Impact Sockets                                    7/16" – 1-3/8"  
 Impact Sockets Metric                        10mm – 19mm  
 Wrenches    7/16" – 1-3/8"  
 Wrenches Metric                                10mm – 19mm  
 Torque Wrench  
 Center Punch and Hammer

### INSTALLATION NOTES

1. Unless otherwise specified, mount all Subframe Components to vehicle before tightening any hardware.
2. It is recommended that **LOCTITE®**, or similar thread locking product, be used on **ALL** mounting hardware (i.e. Nuts, Cap Screws, Bolts, etc.).
3. Vehicle should be parked on a level surface with a normal vehicle load on the FRONT suspension.
4. Items in parentheses ( ) refer to quantity required for this step. Items in parentheses with a pound sign (#) indicate the part number as found in the parts list on the last page of this document. Example: (2) 5/8" x 1-1/2" Cap Screws (#7).
5. It maybe necessary to relocate license plate holder. Relocate under the driver's side headlight by drilling new holes in the bumper.

### MOUNTING INSTRUCTIONS

1. Remove splash guard and tow hook(s) if equipped. Retain, with mounting hardware, for future use if plow Subframe is removed.

*NOTE: It may be necessary to remove front bumper to install Subframe.*

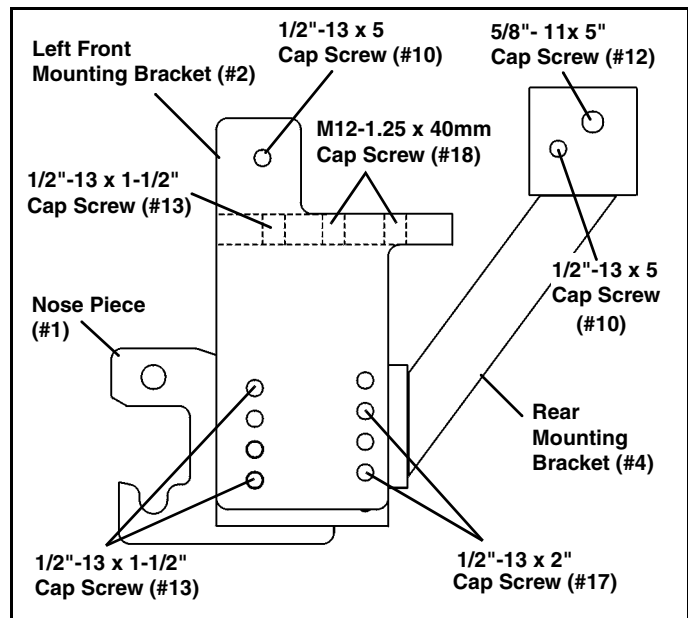

2. Install the Left and Right Front Mounting Brackets (#2 & #3) by aligning the two rear holes in the horizontal plate of the brackets with the existing vehicle frame tow hook holes, securing with (4) M12 - 1.25 x 40mm Cap Screws (#18).

*NOTE: In Step #3 a Nut Plate will be inserted through the front of the each frame rail as a part of the procedure to secure the Front Mounting Brackets. Some grinding to the plate that covers the front opening of each frame rail may be necessary to insert the Nut Plates.*



## WARNING

**Beware of brake and fuel lines secured to inside wall of frame rails when drilling holes in vehicle frame!**

**FAILURE TO HEED CAN RESULT IN INJURY OR DEATH!**

- Using the front hole in the horizontal plate and uppermost hole in the vertical plate of the Front Mounting Brackets as templates, drill 1/4" pilot holes, then 17/32" holes through the bottom of the vehicle frame and through the frame on the side of the vehicle. Secure through the bottom of the frame using (2) 1/2" x 1-1/2" Cap Screws (#13), (2) Lock Washers (#15) and Nut Plates (#6). Secure through the side of the frame with (2) 1/2" x 5 Cap Screws (#10), (2) 1/2" Flat Washers (#14), and (2) 1/2" Nylock Nuts (#16).
- Install the Mounting Assembly (#1). Secure first to the Front Mounting Brackets using (4) 1/2" x 1-1/2" Cap Screws (#13) in the upper and lower front mounting holes. In the threaded holes use (2) 1/2" Lock Washers (#15), in the other holes, use (2) 1/2" Nylock Nuts (#16).

*NOTE: Transmission hoses are located inside the truck frame. Prior to drilling the holes for the Rear Mounting Brackets, loosen hoses with 12mm socket and push up for clearance.*

- Install the Left Rear Mounting Bracket (#4). Align the upper rear hole with the existing hole located in the side of the vehicle frame, install (1) 1/2" x 5 Cap Screw (#10), (1) 1/2" Flat Washer (#14), and secure using (1) Nylock Nut (#16). Using the other hole upper hole in the bracket as a template, drill a 1/4" pilot hole then a 17/32" hole all the way through the vehicle frame. Insert the Tube Spacer (#8) through the frame, place Backing Plate (#7) against the inside of the frame, insert (1) 5/8" x 5 Cap Screw (#9) from the engine side through all and secure with (1) 5/8" Flat Washer (#11) and (1) 5/8" Nylock Nut (#12).
- Install the Right Rear Mounting Bracket (#5) using the same procedure as Step 5.
- Secure the Left and Right Rear Mounting Brackets (#4 & #5) to the Mounting Assembly using, per side, (2) 1/2" x 2" Cap Screws (#17) and (2) 1/2" Nylock Nuts (#16).
- Using the torque specification chart provided, torque all bolts.

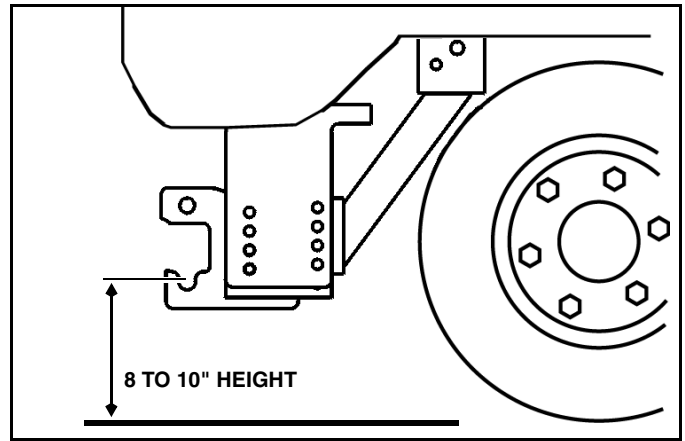

**IMPORTANT:** Height from the center of the lower Plow Mounting holes on the Subframe to the ground should be between 8" and 10" to insure proper operation.



## WARNING

**Beware of brake and fuel lines secured to inside wall of frame rails when drilling holes in vehicle frame!**

**FAILURE TO HEED CAN RESULT IN INJURY OR DEATH!**

### TORQUE SPECIFICATIONS FOR STANDARD MACHINE HARDWARE

Bolt Size	GR.2 Dry	GR.5 Dry	GR.8 Dry	Metric Size	GR.8.8 Dry
1/4"	66*	9	12	M8	17
5/16"	11	17	25	M10	35
3/8"	20	30	45	M12	60
7/16"	32	50	70	M14	95
1/2"	50	75	110	M16	155
9/16"	70	110	150		
5/8"	100	150	220		
3/4"	175	260	380		
7/8"	170	430	600		
1"	250	640	900		

Note: These torque values are to be used for all hardware. Unless otherwise specified, all torque values must meet this specification.

Note: All torque values are in Ft.-Lbs unless otherwise stated

Note: \*In-Lbs

**REMEMBER** After 5 to 10 hours of snowplow usage, re-torque all Cap Screws!

# PARTS LIST

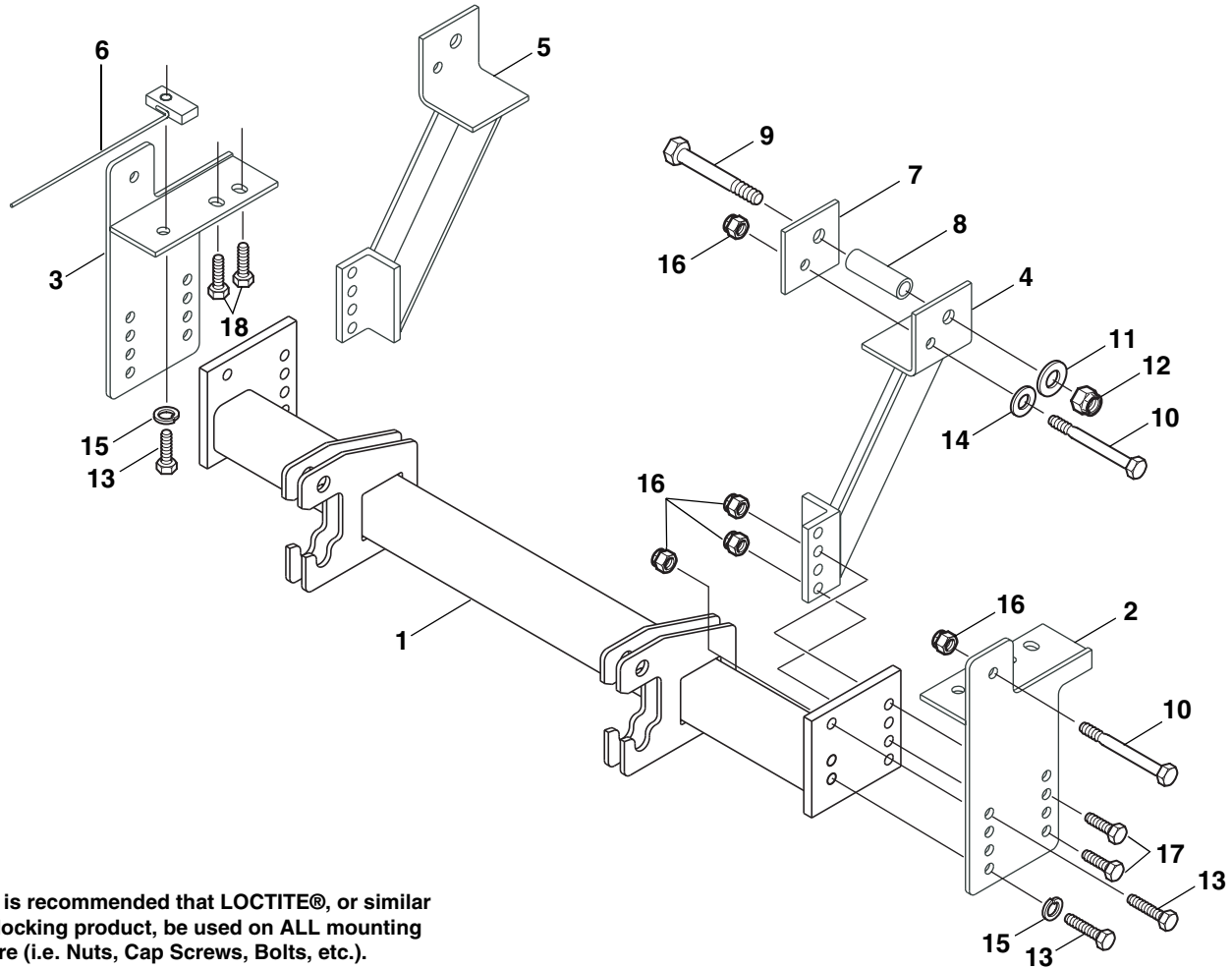

Note: It is recommended that LOCTITE®, or similar thread locking product, be used on ALL mounting hardware (i.e. Nuts, Cap Screws, Bolts, etc.).

ITEM	PART NO.	DESCRIPTION	QTY.
1	96107104	Mounting Assembly .....	1
2	96106013	Front Mounting Bracket, LH .....	1
3	96106014	Front Mounting Bracket, RH .....	1
4	96106015	Rear Mounting Bracket, LH .....	1
5	96106016	Rear Mounting Bracket, RH .....	1
6	96104171	Nut Plate Assembly .....	2
7	96104107	Backing Plate .....	2
8	96104099	Tube Spacer .....	2
9	98009196	Hex Head Cap Screw, 5/8" - 11 x 5 .....	2
10	98009043	Hex Head Cap Screw, 1/2" - 13 x 5 .....	4
11	98009039	Flat Washer, 5/8" .....	2
12	98009038	Nylock Hex Nut, 5/8" - 11 .....	2
13	98009010	Hex Head Cap Screw, 1/2" - 13 x 1-1/2" .....	6
14	98009011	Flat Washer, 1/2" .....	2
15	98009012	Lock Washer, 1/2" .....	4
16	98009013	Nylock Hex Nut, 1/2" - 13 .....	10
17	98100094	Hex Head Cap Screw, 1/2" - 13 x 2 .....	4
18	98009054	Hex Head Cap Screw, M12 - 1.25 mm x 40 mm .....	4

SNO-WAY® INTERNATIONAL, INC.



Hartford, WI 53027 USA  
 Website: [www.snoway.com](http://www.snoway.com)  
 ©2005 Sno-Way® International