

Assembly & Installation Instructions

**FOR
SUBFRAME COMPONENTS PACKAGE 99100384
AND
SUBFRAME NOSE PIECE PACKAGE 96103001**

**TO FIT
1997 - LATER DODGE DAKOTA PICKUP 4X4
1997 - LATER DODGE DURANGO 4X4**



1. **THINK SAFETY, ALWAYS WEAR SAFETY GLASSES WHEN PERFORMING THE OPERATIONS PRESCRIBED IN THESE INSTRUCTIONS**
2. **READ ALL INSTRUCTIONS CAREFULLY BEFORE ATTEMPTING INSTALLATION**
3. **BEFORE BEGINNING WORK MAKE SURE TO SET PARKING BRAKE AND CHOCK WHEELS**



MINIMUM VEHICLE RECOMMENDATIONS

Heavy Duty Alternator Heavy Duty Battery

NOTE: On some vehicles it may be necessary to use a form of load booster to decrease the vehicle's front suspension sag with the snow plow in place. This can be accomplished with the use of supplementary air bags, booster springs, or similar load boosting devices. Since there are different load boosting devices available, it will up to the customer/end user to decide and purchase the product to suit the application, and not the responsibility of Sno-Way International, Inc.

ASSEMBLY TOOLS NEEDED

Impact Sockets	7/16" – 1-3/8"
Metric Sockets	10 – 19 mm
Wrenches	7/16" – 1-3/8"
Metric Wrenches	10 – 19 mm
Torque Wrench	

INSTALLATION NOTES

1. **Unless otherwise specified, mount all Sub-Frame Components to vehicle before tightening any hardware.**
2. **It is recommended that LOCTITE®, or similar thread locking product, be used on ALL mounting hardware (i.e. Nuts, Cap Screws, Bolts, etc.).**
3. Vehicle should be parked on a level surface with a normal vehicle load on the FRONT suspension.
4. Items in parentheses () refer to quantity required for this step. Items in parentheses with a pound sign (#) indicate the part number as found in the parts list on the last page of this document.
Example: (2) 5/8" x 1-1/2" Cap Screws (#7).
5. It may be necessary to relocate license plate holder. Check state and local laws for placement, if needed.

5. Clamp the bumper brackets to the frame and drive out the front four metric bolts from both sides. Remove the clamp and retain the bolts in the event the subframe is removed from the vehicle.
6. Raise the Front Crossmember (#2) and slide the brackets inside the box frame horns. The slots on the brackets slide over the existing serrated button head bolts at the rear of the box frame horns.

MOUNTING INSTRUCTIONS

1. If vehicle is equipped with bumper lamps, disconnect light harness so that bumper can be removed.
2. Remove four bumper bolts from the top of bumper brackets located under the vehicle hood. Remove remaining bumper bracket bolts on side of vehicle frame. Remove bumper and retain hardware for reinstallation in later step.
3. Remove snap fasteners and air deflector.
4. Remove the six metric nuts on the metric bolts located inside the box frame horn on either side of the vehicle. Retain two metric nuts for reinstallation and save the other metric nuts in the event the subframe is removed from the vehicle.

NOTE: Only the four M12 serrated button head screws at the front of the frame horns need to be driven out. The screws near the back of the radiator can remain in place.

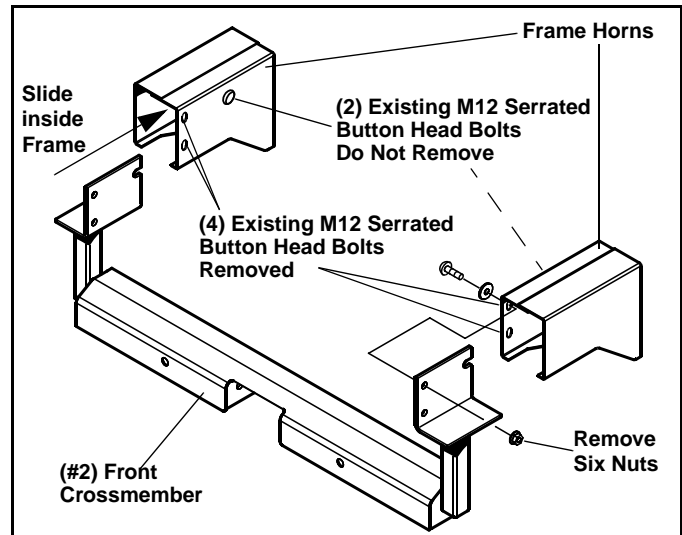

7. Align the holes in the Front Crossmember brackets with the holes of the vehicle box frame horn which the serrated button head bolts were driven out of.
8. Secure the Front Crossmember in place in the following manner. Apply a thread locking product, such as LOCTITE® to the threads of the two serrated button head bolts that were left in place and fasten with the removed nuts from Step 4. From the engine side of the vehicle box frame insert (4) 7/16" x 1-1/2" Cap Screws (#11) with Washers (#13) into the inside of the frame. Secure using (4) Nylock Nuts (#12) with Washers (#13).

9. Remove the plastic hole covers from each side of the vehicle frame crossmember to provide access for installing the Nut Plate Assemblies (#4) into the frame.
10. Place the Rear Crossmember (#3) in position against the vehicle frame crossmember. Insert (4) 5/8" x 2" Cap Screws (#9) with Lock Washers (#10) through the holes and align with the Nut Plate Assembly (#4) inside the vehicle frame.
11. Place the Nose Piece (#1) in position and secure to subframe Front Crossmember with (4) 5/8 x 1-1/2" Cap Screws (#7) and (4) Washers (#6) and (4) Nylock Nuts (#5). Secure Nosepiece to Rear Crossmember with (2) 5/8 x 1-1/2" Cap Screws (#7), (2) 5/8 x 3" Cap Screws (#8) and (4) Nylock Nuts (#5).

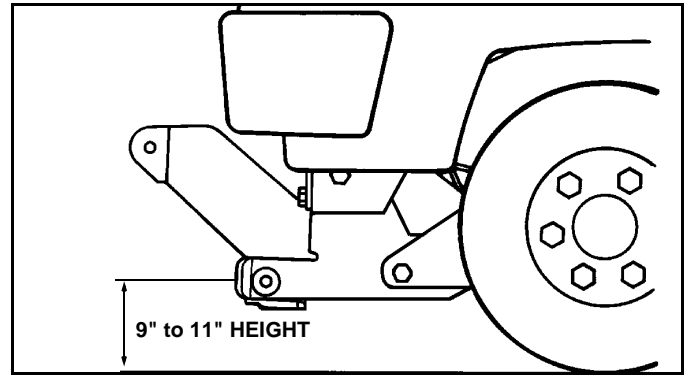

12. Using the Torque Specification Chart below, torque all bolts **starting at the rear** and working forward, torque all hardware (i.e. Nuts, Bolts, etc...).

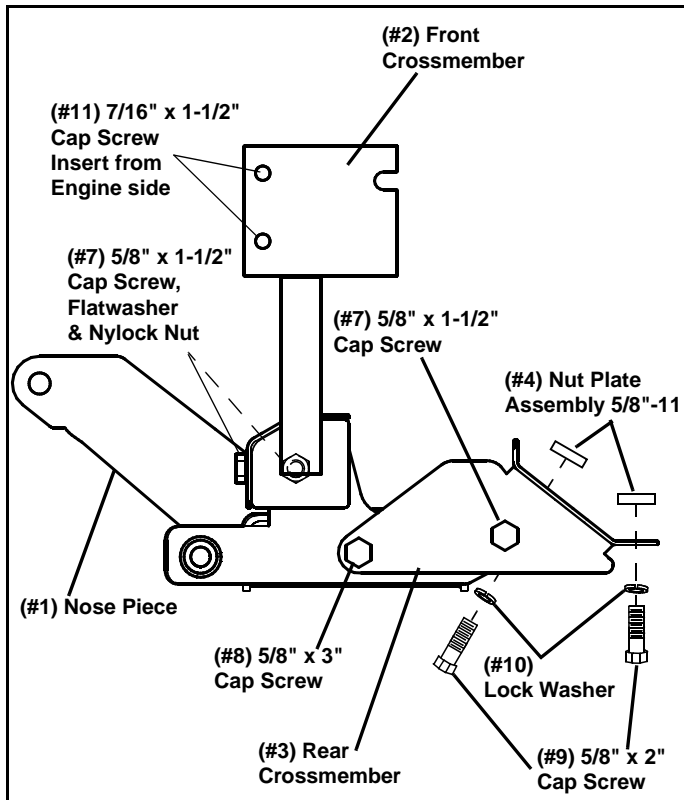

IMPORTANT: Height from the center of the lower Plow Mounting holes on the Sub-Frame to the ground should be between 9" and 11" to insure proper operation.

TORQUE SPECIFICATIONS FOR STANDARD MACHINE HARDWARE

Bolt Size	GR.2 Dry	GR.5 Dry	GR.8 Dry	Metric Size	GR.8.8 Dry
1/4"	66*	9	12	M8	17
5/16"	11	17	25	M10	35
3/8"	20	30	45	M12	60
7/16"	32	50	70	M14	95
1/2"	50	75	110	M16	155
9/16"	70	110	150		
5/8"	100	150	220		
3/4"	175	260	380		
7/8"	170	430	600		
1"	250	640	900		

Note: These torque values are to be used for all hardware. Unless otherwise specified, all torque values must meet this specification.
 Note: All torque values are in Ft.-Lbs unless otherwise stated
 Note: *In-Lbs

REMEMBER After 5 to 10 hours of snowplow usage, re-torque all Cap Screws!

13. Reinstall Front Bumper on to vehicle. Reinstall driving light harness plugs if so equipped.

NOTE: Front air dam can be modified to clear Sub-Frame by cutting dam to allow clearance for nose of Sub-Frame. Cut air dam as shown and remove cut section or fold back for when nose piece is removed.

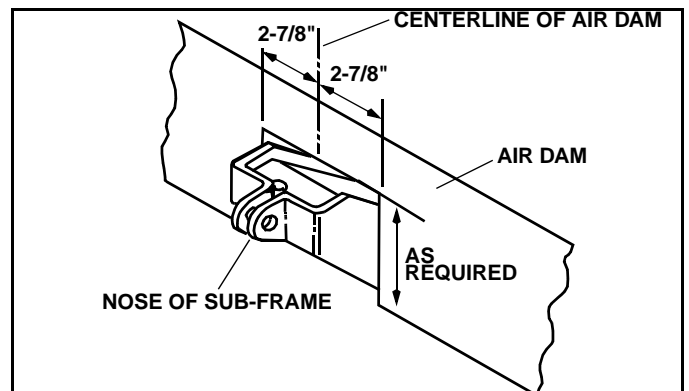

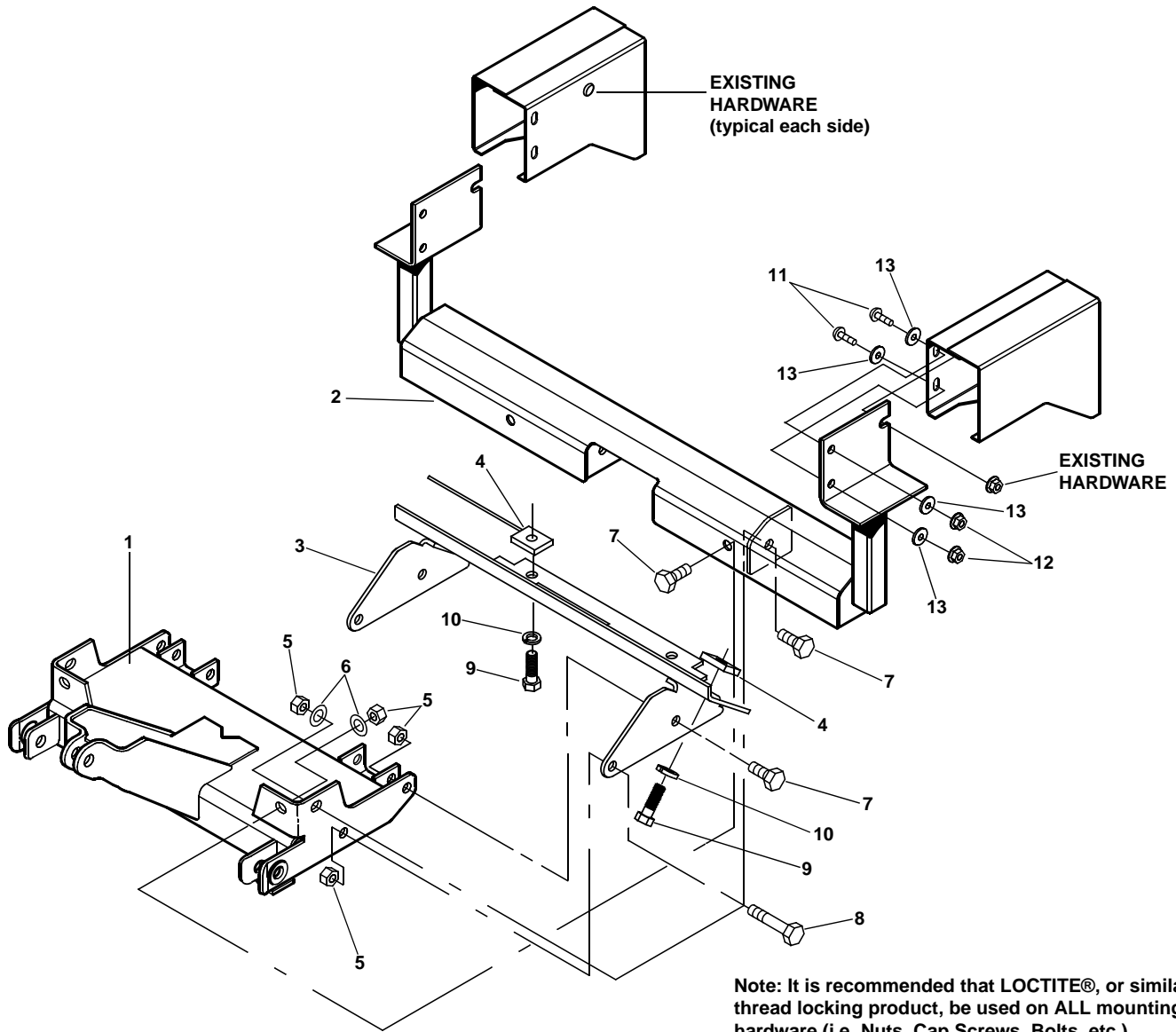

Note: It is recommended that LOCTITE®, or similar thread locking product, be used on ALL mounting hardware (i.e. Nuts, Cap Screws, Bolts, etc.).

ITEM	PART NO.	DESCRIPTION	QTY.
1	96103001	Sub-Frame, Nose Piece (96102924).....	1
2	96103124	Crossmember, Front.....	1
3	96103532	Crossmember, Rear	1
4	96103557	Assembly, Nut Plate, 5/8" - 11	4
5	98009038	Nut, Hex, Nylock, 5/8"-11	8
6	98009039	Washer, Flat, 5/8"	4
7	98009115	Cap Screw, Hex Head, 5/8"-11 x 1-1/2"	6
8	98009217	Cap Screw, Hex Head, 5/8"-11 x 3".....	2
9	98009041	Cap Screw, Hex Head, 5/8"-11 x 2".....	4
10	98009062	Washer, Lock, 5/8"	4
11	98009048	Cap Screw, Hex Head, 7/16"-14 x 1-1/2"	4
12	98009050	Nut, Hex, Nylock, 7/16"-14	4
13	98009049	Washer, Lock, 7/16"	8

SNO-WAY® INTERNATIONAL, INC.



844 West State Street
 Hartford, WI 53027 USA
 Phone (262) 673-7200
 FAX (262) 673-7409
 ©1999 Sno-Way® International