

**Assembly
&
Installation Instructions**

28 SERIES SNOW PLOW

CONTROL BOX PACKAGE 99100283

FOR

PLOW SERIAL NUMBERS AFTER

28D100000

INSTALLATION INSTRUCTIONS

Tool List

12 Volt Test Light or VOM	
Wrenches	1/4" - 15/16"
Impact Sockets	1/4" - 15/16"
Wire Crimp Tool	
Drill	
Hole Saw	1-3/8"
Drill Bit	7/32"

Electrical Installation

1. Remove the Control Box and Hardware package from the carton.

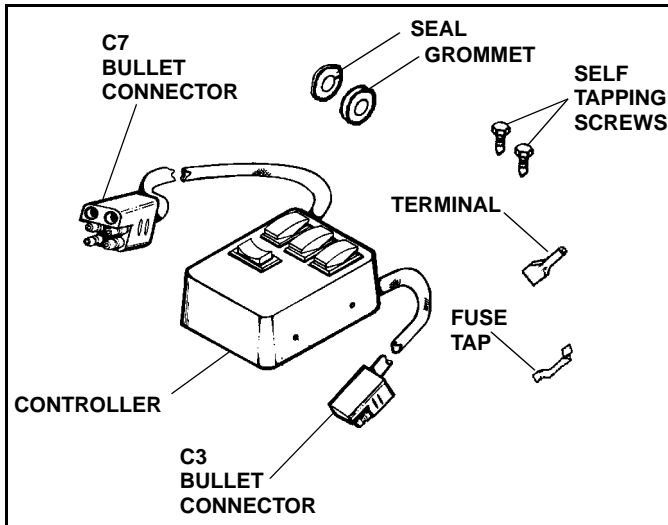

2. Locate the following parts:

- Controller (#96102329)
- Fuse Tap (#96002083), or (#96101832)
- Terminal, Female (#96002085), or (#96101845)
- Grommet (#96100298)
- Neoprene Seal (#96101846)
- Self Tapping Screw (#98009071)

NOTE: Take the extra time needed to plan the routing of the wiring harness before drilling any holes or fastening the harness or control box in place. Read all the instructions carefully to ensure all the required conditions are met for a safe and professional installation.

3. Look for an existing hole, with rubber grommet, in the vehicle firewall. The hole must be 1-3/8" or larger.



CAUTION

DO NOT drill any holes until a thorough visual inspection is performed to determine that the area around the hole to be drilled, on both sides of the firewall, is clear of any obstacles such as brake lines, linkage or vehicle wiring.

4. If an existing 1-3/8" hole is not available, look for an area to drill a 1-3/8" hole that satisfies these conditions;

- Hole should be drilled on the same side of the vehicle firewall (left or right) as the vehicle battery.
- DO NOT put a hole in such a spot that will force the wiring harness, when installed, to interfere or be routed behind accelerator pedal, brake pedal, clutch pedal, parking brake or associated linkage.
- DO NOT drill any holes until a thorough visual inspection is performed to determine that the area around the hole to be drilled, on both sides of the firewall, is clear of any obstacles such as brake lines, linkage or vehicle wiring.

NOTE: If the hole has to be drilled through carpeting or insulation, reverse the direction of the drill until the carpet has been penetrated, remove the carpet from the hole saw then use the forward direction to continue drilling through the firewall, this should prevent "running" in the carpet.

5. Using a hole saw, drill a 1-3/8" hole through the vehicle firewall.



CAUTION

Keep wiring harness away from moving parts, sharp edges and areas of extreme heat to avoid electrical failure and fire.

6. Locate the following items on W1 Wire Harness, located in engine compartment:

- C3 Bullet Connector
- C7 Bullet Connector
- OBlk Wire-with R2 Ring Terminal
- 1Red/Black wire-with bare end

Pass above items through rubber grommet and firewall, then install grommet into firewall.

7. After the Wiring Harness has been positioned install the Adhesive Backed Neoprene Seal over the Harness and against the Rubber Grommet to completely close the opening through the firewall.
8. Remove the Accessory fuse from the vehicle fuse box.

NOTE: Two Fuse Tap-ins are provided, one for standard (ATO/ATC) Automotive Blade Fuses and one for Mini-Blade Automotive Fuses. Determine which type of fuse the vehicle uses. If the standard fuse is used, the Fuse Tap-In will require the provided 1/4" Female Spade Terminal, if the Mini-Fuse is used, the Fuse Tap-in will require the provided 3/16" Female Spade Terminal.

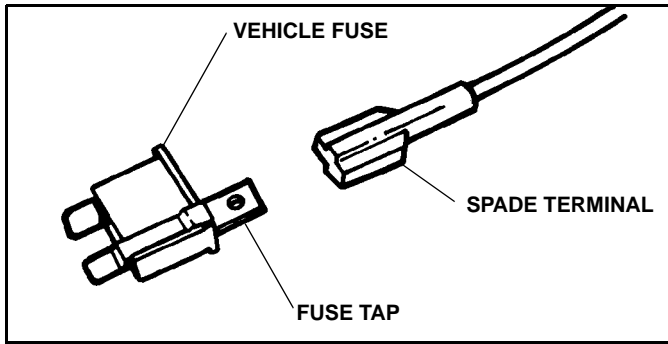

Figure 1-1

NOTE: If accessory fuse is not available in the fuse box use another fuse with a 10-15 Amp designation, i.e. radio, lighter etc.

IMPORTANT: DO NOT use fuse designated for Head-lamp, tail lamp, stop lights, panel lights, or other critical fuses.

9. Using a test probe, determine the fused "Dead/OFF" side of the fuse and attach the appropriate Fuse tap to that side of the fuse.
10. Route the #1Red/Black wire (with bared end), from W1 Wire Harness-Vehicle, to the vehicle fuse box
11. Cut end of wire to length, strip end and install the appropriate female spade terminal onto wire.
12. Attach female spade terminal to appropriate Fuse tap-in and re-install fuse.

IMPORTANT: The #1Red/Black wire must be protected by a fuse. If it is not practical to attach this wire to a fused circuit in the vehicle fuse box an in line 10 amp fuse must be added to this wire.

13. Locate the 0Blk wire, with R2 ring terminal, (from W1 Wire Harness) and attach to a grounding point inside the cab.

Control Box Mounting



WARNING

Mount the control box in an area that will not interfere with the legs during seat travel and that will not allow the knees to come in contact with it in an accident.

1. Make the following harness connections:
 - C3 Bullet Connector from Controller W2 Wire Harness to mating C3 Bullet Connector on W1 Wire Harness.
 - C7 Bullet Connector from Controller W3 Wire Harness to mating C7 Bullet Connector on W1 Wire Harness.



CAUTION

When selecting a location for mounting the Controller make sure there are no wires, brake lines, control cables etc. on the other side of the panel being used to mount the Controller on!

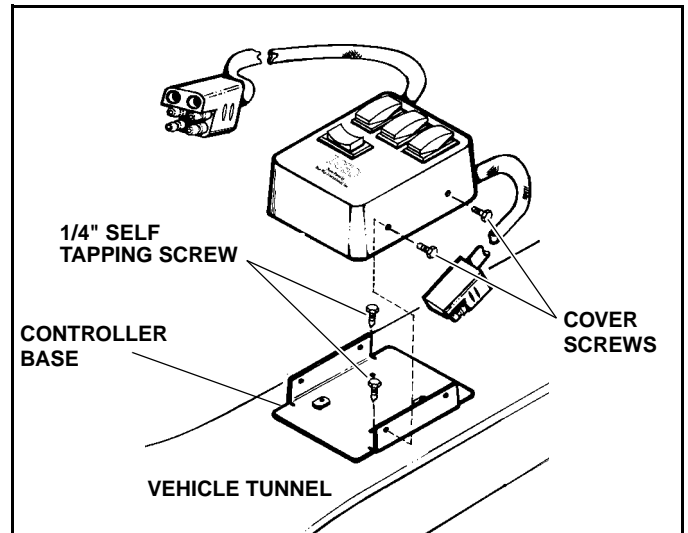

2. Locate a suitable place on the vehicle Transmission Tunnel for mounting the Controller.
3. Remove the Controller Cover from the Controller Base by removing the (4) Cover Screws from the Controller Cover and carefully separating the cover from the base.
4. Position the base in the selected site on the vehicle transmission tunnel. Using it as a template, drill (2) 7/32" pilot holes.
5. Secure Controller Base with the (2) self tapping screws (#98009071) supplied in Control Box Mounting Hardware Kit.
6. Replace the Controller Cover on the Controller Base and secure with the Cover Screws removed in step #3.

IMPORTANT: When installation is completed make sure that wire harness and/or connectors DO NOT come into contact with sharp edges, hot components and DO NOT interfere with moving parts or mechanisms such as brake pedal or linkage, gas pedal, etc.

NOTE: For parts listing refer to the Snow Plow Service Parts Manual (#97100465). For Wiring Diagram, refer to the Snow Plow Set up and Installation Instructions (#97100439) or the Owners Manual (#97100438)

SNO-WAY® INTERNATIONAL, INC.



844 West State Street
Hartford, WI 53027 USA
Phone (262) 673-7200
FAX (262) 673-7409
©1999 Sno-Way® International