



**Assembly
&
Installation Instructions**

**FOR
SUBFRAME COMPONENTS PACKAGE 99100492
AND
SUBFRAME NOSE PIECE PACKAGE 96105077**

**TO FIT
1991 & LATER CHEVROLET & GMC 4X2 C3500HD CHASSIS CAB**



1. **THINK SAFETY, ALWAYS WEAR SAFETY GLASSES WHEN PERFORMING THE OPERATIONS PRESCRIBED IN THESE INSTRUCTIONS**
2. **READ ALL INSTRUCTIONS CAREFULLY BEFORE ATTEMPTING INSTALLATION**
3. **BEFORE BEGINNING WORK MAKE SURE TO SET PARKING BRAKE AND CHOCK WHEELS**



MINIMUM VEHICLE RECOMMENDATIONS

Heavy Duty Alternator Heavy Duty Battery

NOTE: On some vehicles it may be necessary to use a form of load booster to decrease the vehicle's front suspension sag with the snow plow in place. This can be accomplished with the use of supplementary air bags, booster springs, or similar load boosting devices. Since there are different load boosting devices available, it will up to the customer/end user to decide and purchase the product to suit the application, and not the responsibility of Sno-Way International, Inc.

ASSEMBLY TOOLS NEEDED

Drill Bits	17/32"
Sockets	7/16" – 1-1/8"
Wrenches	7/16" – 1-1/8"
Torque Wrench	
Center Punch and Hammer	
Clamping Devices	

INSTALLATION NOTES

1. Unless otherwise specified, mount all Sub-Frame components to vehicle before tightening any hardware.
2. It is recommended that LOCTITE®, or similar thread locking product, be used on ALL mounting hardware (i.e. nuts, cap screws, bolts, etc.).
3. Vehicle should be parked on a level surface with a normal vehicle load on the FRONT suspension.
4. Items in parentheses () refer to quantity required for this step. Items in parentheses with a pound sign (#) indicate the part number as found in the parts list on the last page of this document.
Example: (6) 1/2" x 2" Cap Screws (#8).
5. It maybe necessary to relocate the license plate holder. Relocate under the driver's side headlight by drilling new holes in the bumper. Check state and local laws for placement, if needed.

Nuts (#9). Use (2) washers on each of the four bolts (one on the bottom of the Front Crossmember under the Bolt head and one on the top of the vehicle center channel under the Lock Nut).

3. Attach the Rear Mounting Brackets, LH (#2) and RH (#3). Using the holes in the upper part of the bracket as a template, center punch then drill (on both sides of the frame) a 17/32" hole through the frame. If there is a gap between the frame and the Rear Brackets, insert (1) Shim Plate (#11) if needed. Secure using (4) Nut Plate Assemblies (#5) inserted through the bottom of the frame, (8) 1/2" x 1-1/2" Cap Screws (#6) and (8) 1/2" Lockwashers (#7).
4. Raise (1) Mounting Assembly (#1) and attach to the Front Crossmember using (2) 1/2" x 2" Capscrews (#8) in the top front holes and (2) 1/2" Lock Nuts (#9). In the threaded holes, use (2) 1/2" x 1-1/2" Capscrews (#6) along with (2) 1/2" Lock Washers (#7).

MOUNTING INSTRUCTIONS

1. Position (1) Front Crossmember (#4) at the inside of the vehicle frame rails. Center the Front Crossmember between the frame rails and clamp into place. Now, position both of the Rear Mounting Brackets, LH (#2) and RH (#3), onto the frame. The brackets are positioned in between the vehicle frame mount. It may be necessary to adjust the Front Crossmember in order to fit the Rear Mounting Brackets. Clamp the Rear Mounting Brackets into place, insuring that the hole alignment to the back set of holes in the Front Crossmember and the Rear Mounting Brackets are flush with the bottom of the vehicle frame.
2. Once the Front Crossmember and the Rear Mounting Brackets are clamped to the vehicle properly, attach the Front Crossmember to the vehicle frame. Using the holes in the center section on the Front Crossmember as a template, center punch and drill a 17/32" hole through the center channel of the vehicle. Attach, using (4) 1/2" x 1-1/2" Capscrews (#6), (8) Special Hardened Washers (#10), and (4) 1/2" Lock

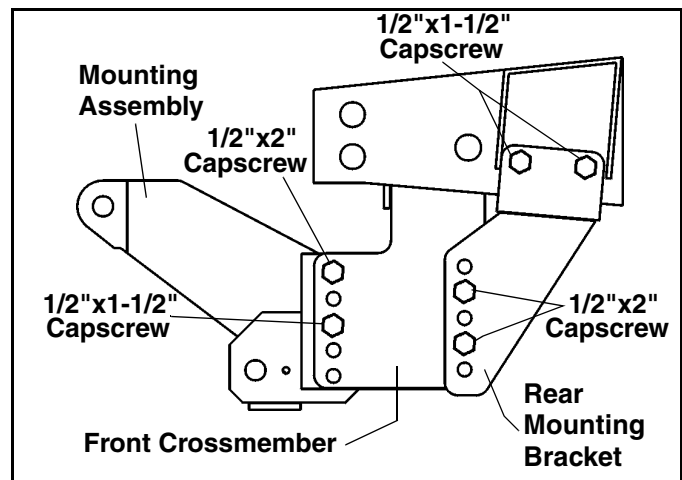

5. Secure the Mounting Assembly to the Front Crossmember and the Rear Mounting Brackets using (4) 1/2" x 2" Capscrews (#8) and (4) 1/2" Lock Nuts (#9), two on each side.
6. Using the Torque Specification Chart provided, torque all cap screws.

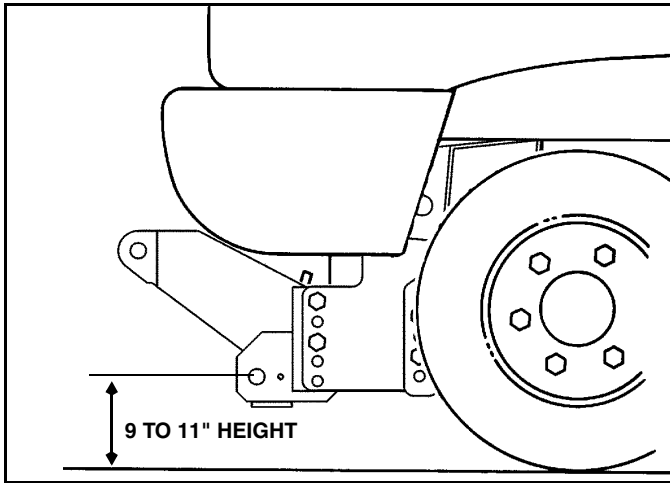

IMPORTANT: Height from the center of the lower Plow Mounting holes on the Sub-Frame to the ground should be between 9" and 11" to insure proper operation.

TORQUE SPECIFICATIONS FOR STANDARD MACHINE HARDWARE					
Bolt Size	GR.2 Dry	GR.5 Dry	GR.8 Dry	Metric Size	GR.8.8 Dry
1/4"	66*	9	12	M8	17
5/16"	11	17	25	M10	35
3/8"	20	30	45	M12	60
7/16"	32	50	70	M14	95
1/2"	50	75	110	M16	155
9/16"	70	110	150		
5/8"	100	150	220		
3/4"	175	260	380		
7/8"	170	430	600		
1"	250	640	900		

These torque values are to be used for all hardware. Unless otherwise specified, all torque values must meet this specification.
 All torque values are in Ft.-Lbs unless otherwise stated
 *In-Lbs

REMEMBER After 5 to 10 hours of snowplow usage, re-torque all Cap Screws!

PARTS LIST

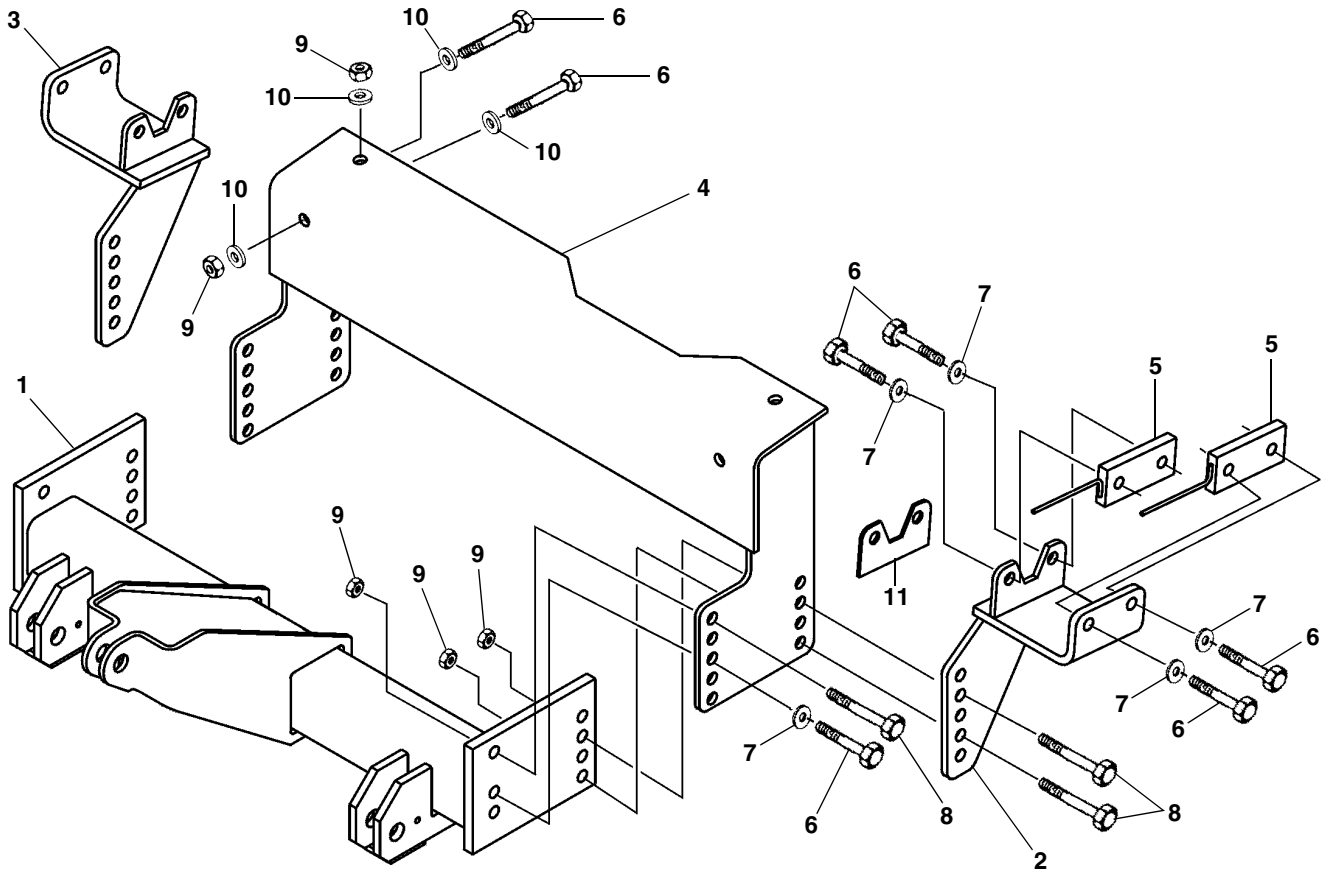

Note: It is recommended that LOCTITE®, or similar thread locking product, be used on ALL mounting hardware (i.e. Nuts, Cap Screws, Bolts, etc.).

ITEM	PART NO.	DESCRIPTION	QTY.
1	96105077	Mounting Assembly.....	1
2	96105096	Bracket, Rear Mounting, LH.....	1
3	96105097	Bracket, Rear Mounting, RH.....	1
4	96105174	Crossmember, Front.....	1
5	96105186	Assembly, Nut Plate.....	4
6	98009010	Cap screw, Hex Head, 1/2" x 1-1/2".....	14
7	98009012	Washer, Lock, 1/2".....	10
8	98100094	Cap Screw, Hex Head, 1/2" x 2".....	6
9	98009013	Nut, Hex, 1/2" Nylock.....	10
10	98100176	Washer, Special Hardened.....	8
11	96105319	Plate, Shim.....	2

SNO-WAY® INTERNATIONAL, INC.



Hartford, WI 53027 USA
 Website: www.snoway.com
 ©2001 Sno-Way® International