



# OWNER'S MANUAL

**24 SERIES SNOW PLOW**

**25 SERIES SNOW PLOW**

**WITH**

**DOWN PRESSURE SYSTEM**

**FOR PLOW SERIAL NUMBERS AFTER**

**24D100000**

**25D100000**



# TABLE OF CONTENTS

	Page
INTRODUCTION .....	2
SAFETY .....	3
THEORY OF OPERATION.....	4
PLOWING OPERATION.....	7
Operating Classes .....	7
Before The Season Begins .....	7
Transporting Vehicle With Plow Attached .....	7
Plowing Like A Pro .....	8
Using The Down Pressure (DP) Hydraulic System.....	8
Clearing Driveways.....	8
Clearing Parking Lots.....	9
Mounting Snow Plow To Vehicle .....	9
Installing The Transport Lock Clamp.....	10
Removing Snow Plow From Vehicle .....	11
TROUBLE SHOOTING GUIDE .....	13
MAINTENANCE .....	18
General .....	18
Break In Period.....	18
Periodic Inspection.....	18
Hydraulic Cylinders .....	18
Electrical Quick Disconnect Plug.....	18
Polycarbonate Blade Care .....	19
Service Intervals .....	19
Fluid Requirements .....	19
Changing Oil and Cleaning Filter Screen .....	19
Disk Shoe Adjustment.....	22
Cutting Edge .....	22
Trip Spring Adjustment .....	23
TORQUE SPECIFICATIONS.....	24
HYDRAULIC SCHEMATIC (Down Pressure System) .....	25
WIRING SCHEMATIC ROCKER SWITCH STYLE (Down Pressure System).....	26
WIRING SCHEMATIC JOY STICK STYLE (Down Pressure System).....	27
WARRANTY .....	29

# INTRODUCTION

This manual was written for the assembly, installation and maintenance of your new Sno-Way Plow. Most importantly, this manual provides an operating plan for safe use. Refer to the Table of Contents for an outline of this manual.

Please keep this manual with your machine at all times as reference material and so it can be passed on to the next owner if the machine is sold.

We require that you read and understand the contents of this manual COMPLETELY, especially the chapter on SAFETY, before attempting any procedure contained in this manual.



The Society of Automotive Engineers has adopted this SAFETY ALERT SYMBOL to pinpoint characteristics that, if NOT carefully followed, can create a safety hazard. When you see this symbol in this manual or on the machine itself, BE ALERT!, your personal safety and the safety of others, is involved.

• Defined in the next column, are the SAFETY ALERT messages and how they will appear in this manual.



**FAILURE TO HEED CAN RESULT IN SERIOUS INJURY OR DEATH.**



**Information, that if not carefully followed, can cause minor injury or damage to equipment!**

*NOTE: Additional information concerning the equipment or the procedure that may or may not be contained elsewhere in this manual.*

**BE AWARE! It is illegal to remove, deface or otherwise alter the safety decals mounted on this equipment.**

Record the Power Pack Model Number, Power Pack Serial Number, Controller Serial Number, Blade Model Number, Blade Serial Number And The Pump Serial

Number in the space provided below as a handy record for quick reference. The Power Pack Serial Number is located on the A-Frame of the Power Pack, the blade serial number is located on one of the middle ribs of the blade. This plate contains information that your Dealer needs to answer questions or to order replacement parts, if needed, for your unit.

NAME PLATE DATA	
POWER PACK MODEL NUMBER	_____
POWER PACK SERIAL NUMBER <small>(Located on A-Frame of Power Pack)</small>	_____
CONTROLLER SERIAL NUMBER	_____
BLADE MODEL NUMBER	_____
BLADE SERIAL NUMBER <small>(Located on Blade Frame)</small>	_____
PUMP SERIAL NUMBER	_____
(FILL IN)	

DEALER		
NAME	_____	
ADDRESS	_____	
CITY	STATE	ZIP
PHONE ( )-	_____	
(FILL IN)		

ORIGINAL PURCHASER		
NAME	_____	
ADDRESS	_____	
CITY	STATE	ZIP
PHONE ( )-	_____	
(FILL IN)		

We reserve the right to make changes or improve the design or construction of any part(s) without incurring the obligation to install such parts or make any changes on any unit previously delivered.

Sno-Way snow plow Service Parts Manuals are available for purchase from your authorized Sno-Way dealer. Sno-Way snow plow Service Parts Manuals may also be ordered from the address on the back of this manual by requesting part number 97100204.



## SAFETY



**BEFORE ATTEMPTING ANY PROCEDURE IN THIS BOOK, READ AND UNDERSTAND ALL THE SAFETY INFORMATION CONTAINED IN THIS SECTION. IN ADDITION, ENSURE ALL INDIVIDUALS WORKING WITH YOU ARE ALSO FAMILIAR WITH THESE SAFETY PRECAUTIONS.**

**For your safety Warning and Information Decals have been placed on this product to remind the operator to take safety precautions. It is important that these decals are in place and are legible before operation begins. New decals can be obtained from Sno-Way or your local dealer.**

**REMEMBER** The careful operator is the best operator. Most accidents are caused by human error. Certain precautions must be observed to prevent the possibility of injury to operator or bystanders and/or damage to equipment.

**NEVER** operate Plow when under the influence of alcohol, drugs or other medications that could hamper your judgement and reactions. An accident may result in serious injury or death to other persons or yourself.

**ALWAYS** operate vehicle in a well-ventilated area. The carbon monoxide in exhaust gas is highly toxic and can cause serious injury or death.

**NEVER** allow hands, hair or clothing to get near any moving parts such as fan blades, belts and pulleys. Never wear neckties or loose clothing when working on the vehicle.

**NEVER** wear wrist watches, rings or other jewelry when working on the vehicle or individual equipment. These things can catch on moving parts or cause an electrical short circuit that could result in serious personal injury.

**ALWAYS** wear safety goggles when working on the vehicle to protect your eyes from battery acid, gasoline, and dust or dirt from flying off of moving engine parts.

**ALWAYS** be aware of and avoid contact with hot surfaces such as engine, radiator, and hoses.

**ALWAYS** wear safety glasses with side shields when striking metal against metal! In addition, it is recommended that a softer (non-chipable) metal material be used to cushion the blow. Failure to heed could result in serious injury to the eye(s) or other parts of the body.

**NEVER** allow children or unauthorized person to operate this unit.

**NEVER** exceed 45 m.p.h. when snow plow is attached to vehicle. Braking distances may be reduced and handling characteristics may be impaired at speeds above 45 m.p.h.

**ALWAYS** lock the vehicle when unattended to prevent unauthorized operation of the plow.

**ALWAYS** check the job site for terrain hazards, obstructions and people.

**NEVER** exceed 10 m.p.h. when plowing. Excessive speed may cause serious injury and damage of equipment and property if an unseen obstacle is encountered while plowing.

**ALWAYS** position blade so it does not block path of headlamps beam. Do not change blade positions while traveling. An incorrect plow position blocking headlamp beam may result in an accident.

**ALWAYS** check surrounding area for hazardous obstacles before operating this unit.

**ALWAYS** inspect the unit periodically for defects. Parts that are broken, missing or plainly worn must be replaced immediately. The unit, or any part of it should not be altered without prior written approval of the manufacturer.

**ALWAYS** insert the cylinder lock when plow is not in use. If the cylinder lock is not installed, the plow blade could inadvertently drop and cause serious injury.

**ALWAYS** shut off the vehicle engine, place the transmission in Neutral or Park, turn the ignition switch to the "OFF" position and firmly apply the parking brake of the vehicle before attaching or detaching the blade from the vehicle or when making adjustments to the blade.

**ALWAYS** inspect lift system bolts and pins whenever attaching or detaching the plow, and before traveling. Worn or damaged components could result in the plow dropping to the pavement while driving, causing an accident.

**ALWAYS** keep hands and feet clear of blade and A-Frame when attaching or detaching plow.

**NEVER** place fingers in A-frame or mount lug holes to check alignment when attaching snow plow. Sudden motion of the plow could severely injure a finger.

**NEVER** stand between the vehicle and blade or directly in front of blade when it is being raised, lowered or angled. Clearance between vehicle and blade decreases as blade is operated and serious injury or death can result from blade striking a body or dropping on hands or feet.

**NEVER** work on the vehicle without having a fully serviced fire extinguisher available. A 5 lb or larger CO<sup>2</sup> or dry chemical unit specified for gasoline, chemical or electrical fires, is recommended.

**NEVER** smoke while working on the vehicle. Gasoline and battery acid vapors are extremely flammable and explosive.

**NEVER** use your hands to search for hydraulic fluid leaks; escaping fluid under pressure can be invisible and can penetrate the skin and cause a serious injury! If any fluid is injected into the skin, see a doctor at once! Injected fluid **MUST BE** surgically removed by a doctor familiar with this type of injury or gangrene may result.

**REMEMBER** it is the owner's responsibility for communicating information on the safe use and proper maintenance of this machine.

# THEORY OF OPERATION

## Hydraulic Power Unit

The hydraulic power unit consists of:

- 12VDC Motor
- Hydraulic Pump rated at 1.03 GPM @ 1400 PSI
- 1 quart capacity Reservoir
- fine mesh Intake Filter
- Magnet

The fluid supply line for the pump is submerged in the Reservoir and is equipped with a fine mesh Intake Filter. Further protection of the Hydraulic system is provided by a Magnet located in the Sump.

The 12VDC Motor is protected electrically by 150A Circuit Breaker located between the vehicle battery and the Motor Solenoid.

The Hydraulic Pump is protected by a 1750 psi System Relief Valve.

This unit is equipped with a DOWN PRESSURE OPTION that allows the operator to selectively switch the system to provide additional Hydraulic force to the lowering of the plow.

**IMPORTANT: The electric coils, which operate the solenoid valves, require a minimum of 9-1/2 volts DC for proper operation. Lower Voltage will cause erratic operation, or failure to operate.**

## Hydraulic Controls

The Hydraulic Controls consists of:

- One dual solenoid, spring centered, three position Angle Valve
- Two Crossover Relief Valves, 2000 psi
- System Pressure Relief Valve, 1750 psi
- One single solenoid, spring return, two position Lower Valve
- One system Check Valve
- Two single acting Angle Cylinders, right and left
- One double acting Raise Cylinder
- One single solenoid, two position, spring return, 4-Way Valve
- Down Pressure (DP) Relief Valve

## Raise Mode Of Operation

Electrical current is provided to the Raise/Lower Switch center terminals (common) through the 9 RED/BLK wire, any time the vehicle key switch is in the ACC or RUN position.

The Raise/Lower Switch is a three position, ON-OFF-MOMENTARY ON switch. The switch will automatically return to OFF from the Raise ON position, and will lock in the Lower/Float ON position until cancelled by the operator.

Activating the Raise Switch establishes a circuit allowing current to flow through the Raise/Lower Switch to the Motor Solenoid primary circuit, through the 10 BROWN wire, which activates the Motor Solenoid.

Activating the Motor Solenoid closes the secondary contacts allowing current to pass from the vehicle battery, through the 2B RED wire and the 150A Circuit Breaker, to the 12VDC Motor. The 12VDC Motor is direct coupled to the Hydraulic Pump.

Hydraulic fluid, under pressure, is directed to the Angle Valve. If the Angle Switch is not activated the Angle Valve will be in the Neutral, centered, position and fluid will flow through the Angle Valve, Check Valve, and to the 4-Way Valve. If the DP Switch is not energized the fluid will flow through the 4-Way valve to the base end of the Raise Cylinder. Pressurizing the base end of the Raise Cylinder will cause the cylinder rod to extend and lift the Plow.

The raise circuit is protected by the System Pressure Relief Valve set to relieve system pressure at approximately 1750 PSI.

Releasing the Raise Switch de-energizes Motor Solenoid interrupting current to the 12 VDC Motor. The Plow will remain in the raised position until the Lower Switch is activated.

*NOTE: If the Raise/Lower Switch is initially in the Lower/Float position actuating the Raise side of the switch will also break the circuit to the Lower Solenoid, which allows the Lower Valve to shift, under spring pressure, to the blocked port position.*

## Lower Mode Of Operation

Electrical current is provided to the Raise/Lower Switch center terminals (common) through the 9 RED/BLK wire, any time the vehicle key switch is in the ACC or RUN position.

Activating the Lower Switch allows current to flow through the Raise/Lower Switch to the Lower Solenoid, through the 7 BLK wire. The Lower Solenoid shifts the Lower Valve to the open port position which establishes a flow path from the base end of the Raise Cylinder to the sump. This lowers the plow and establishes a float circuit. The float circuit allows fluid to exit the Raise Cylinder allowing the plow to follow the contours of the ground.

**IMPORTANT: The lower valve is closed by spring pressure. If it does not close completely against the valve seat, the plow can slowly lower after the raise switch is released. If this occurs, cycle the plow through a raise and lower cycle a few times to flush out anything that may be between the valve and seat, this also allows the valve and valve seat to mate and seal.**

## Down Pressure (DP) System

The Down Pressure (DP) System consists of two separate but interactive electrical circuits, both controlled by the DP Toggle Switch.

- 4-Way Valve - Controls fluid flow to and from the Raise Cylinder and establishes either a float or DP condition.
- DP Pressure Switch - a pressure sensitive ON switch that controls the pressure available to the DP system by limiting the Motor run time in the DP mode.

Electrical current is provided to the DP Toggle Switch center terminals (common) through the 14 Pnk wires from the Raise/Lower Switch "lower" terminals. The Raise/Lower Switch must be in the Lower position for the DP to be activated. The Raise/Lower Switch receives power through the 9 RED/BLK wire, any time the vehicle key switch is in the ACC or RUN position.

Positioning the DP Toggle Switch to ON supplies power to the Indicator Light, and allows current to flow, through 11 Blue wire, to the Four-way Valve. Current also flows from the DP Toggle Switch, through 12 Yellow wire, and supplies power to the Pressure Switch.

- The 4-Way Valve, when energized, directs fluid flow to the rod end of the Raise Cylinder creating pressure in the Raise Cylinder and forcing the plow down. When the 4-Way Valve is de-energized (Down Pressure Toggle Switch in the OFF position) a spring returns the 4-Way valve to a open port position that opens all ports in the Raise Cylinder allowing the blade to float and follow the contour of the ground.
- The DP Pressure Switch senses hydraulic pressure in the rod end circuit of the Raise Cylinder. When pressure falls below the Pressure Switch preset, the Pressure Switch closes and current is supplied, through 14 Tan wire, to activate the Motor Solenoid allowing the 12VDC Motor and Hydraulic Pump to create hydraulic pressure which is supplied to the rod end of the Raise Cylinder. When pressure increases the pressure switch opens and stops current flow to the Motor Solenoid which disrupts power to the 12VDC Motor.

The down pressure system is protected by the DP Relief Valve. If, while in the DP mode, an obstacle is encountered forcing the blade up excess pressure will be created in the rod end of the Raise Cylinder. This excess pressure is

relieved to the sump by the DP Relief Valve. Once the obstacle is cleared the plow will lower back to the surface being plowed, lowering Raise Cylinder pressure, and the Pressure Switch will then close re-establishing correct DP system pressure.

The down pressure system will be over ridden when the toggle switch is placed in raise, but will resume when placed back into float position.

## Angle Left or Right Mode Of Operation

Electrical current is provided to the Right/Left Switch center terminals (common) through the 9 RED/BLK wire, any time the vehicle key switch is in the ACC or RUN position.

The Angle Switch is a three position, momentary contact ON-OFF-ON switch that is spring loaded to return to the OFF position.

Operating the Angle Switch simultaneously:

- establishes a circuit allowing current to flow through the Right/Left Switch to the Motor Solenoid primary circuit, through the 10 BROWN wire, which activates the Motor Solenoid. Activating the Motor Solenoid closes the secondary contacts allowing current to pass from the vehicle battery, through the 2B RED wire and the 150A Circuit Breaker, to the 12VDC Motor. The 12VDC Motor is direct coupled to the Hydraulic Pump.
- activates either the Angle Left Solenoid, 6 GREEN wire, or Angle Right Solenoid, 5 RED wire. The solenoids are located on either end of the Angle Valve Spool which is spring loaded to the center position. When one of the solenoids is activated the Angle Valve Spool shift directing hydraulic fluid, under pressure, to the base end of the respective Angle Cylinder to angle the Blade left or right.

The angle left or angle right hydraulic circuits receive priority over the raise hydraulic circuit. If the raise circuit is operated while angling the blade left or right, the blade will angle left or right but will not raise until the Angle Switch is released. Angling the blade left or right while lowering the plow will allow the blade to angle and to lower simultaneously because hydraulic pressure is not needed to lower the plow.

The angle circuits are protected by two Crossover Relief Valves set to relieve pressure at approximately 2000 PSI. If the blade comes in contact with an obstacle during plowing operations the Crossover Relief Valves will allow the blade to automatically adjust its angle to clear the obstacle.

Example: Blade is in straight position, an obstacle is hit with right side of blade creating more than 2000 psi in Right Cylinder. The Crossover Relief Valve relieves pressure from the Right Cylinder and pressurizes the Left Cylinder causing the blade to angle to the right.

*NOTE: The Cross Over Relief Valves are ineffective if the blade is at maximum angle, against Swing Frame stop, and an object is struck.*

## **Motor Solenoid**

Current to energize the DC Motor is supplied through the Motor Solenoid. Current to activate the Motor Solenoid may come through either:

- the 10 BROWN wire from the Raise/Lower Switch or Angle Left/Right Switch.
- or through the 13TAN wire from the DP Pressure Switch.

The DP Pressure Switch is a normally closed pressure sensing switch that opens at a preset pressure. The DP Pressure Switch receives current from the DP Toggle Switch through the 12 YELLOW wire. See "Down Pressure (DP) System" on page 5

## **Circuit Breaker**

A 150 Amp Circuit Breaker is located in the 2 RED wire between the vehicle battery and the Motor Solenoid. This Circuit breaker protects the 12VDC Motor. A high Amp draw condition in the 12VDC Motor will cause an element in the Circuit Breaker to interrupt current flow to the 12VDC Motor, and will automatically reset when it cools down.

## **Controls And Indicators**

### **Raise/Lower Switch:**

The Raise/Lower Switch is a three position, ON-OFF-MOMENTARY ON switch. The switch will automatically return to OFF from the Raise ON position, and will lock in the Lower/Float ON position until cancelled by the operator. This switch is used to selectively raise or lower the plow.

### **Angle Left/Right Switch:**

The Angle Switch is a three position, momentary contact ON-OFF-ON switch that is spring loaded to return to the OFF position. This switch is used to selectively angle the plow left or right.

### **Down Pressure (DP) Toggle Switch:**

The Down Pressure (DP) Switch is a two position, ON-OFF switch. The DP Switch is used to activate the DP System. Must be in off position for float system to operate.

### **Down Pressure (DP) On Indicator Light:**

Comes on when DP Switch is turned on. The light indicates switch position only, it does not indicate proper system operation.



# PLOWING OPERATION

## Operating Classes

### 24 Series

The 24 Series SnoWay Plow is specifically designed for light duty snow plowing with full size 1/2, 3/4 ton and midsize 4x4's. This Plow can also be used for some light commercial applications such as lot cleanup, drives and sidewalks.

### 25 Series

The 25 Series SnoWay Plow is specifically designed for heavy duty snow plowing with full size 1/2, 3/4 and 1 ton 4x4's.

## Before The Season Begins

1. Inspect vehicle safety equipment for proper operation; brakes, headlights, plowing lights, windshield wipers, flashers, etc.
2. Inspect the plow, plow frame and all attaching hardware for wear and corrosion. Replace worn or damaged parts and clean and repaint exposed metal parts with a high quality, corrosion resistant enamel.
3. Inspect all fasteners to insure that they are properly tightened. If any fasteners are loose, re-tighten to the proper torque (refer to the Torque Specification Chart in this manual) and carefully inspect the adjacent area for damage or wear as well as carefully inspecting all adjacent fasteners for proper torque.
4. Apply a small amount of light oil to the Hitch Pins and pivots, to Pivot Pins between the Blade Assembly and the Swing Frame, between Raise and Swing Cylinder pivot Pins and the Lift Linkage Pivots.
5. Check for excessive free play between the A-Frame and Swing Frame Pivot. If there is excessive free play adjust the Swing Frame Pivot Pin as described in the "Break In Period" section on page 18 of this manual.
6. If wear is noticed between the A-Frame and Swing Frame apply a good quality Anti-Seize lubricant to this area.
7. Check the reservoir oil level (see maintenance instructions) and repair any oil leaks and worn hoses.
8. Install auxiliary and flashing lights (if not equipped). Ensure auxiliary lights are aimed properly (with plow in full UP position).
9. If ballast is required, position and secure ballast behind rear wheels, for optimum performance.

## Transporting Vehicle With Plow Attached



### WARNING

**Ensure ignition switch is OFF before installing or removing the cylinder lock clamp. Equipment failure or inadvertent operation of the control switches could allow the plow blade to fall, resulting in serious injury.**

**FAILURE TO HEED CAN RESULT IN SERIOUS INJURY OR DEATH.**

1. Always install the cylinder lock clamp when the plow is raised and the operator is not engaged in plowing operations.

*NOTE: If Cylinder Lock Clamp is not installed during transport equipment failure or inadvertent operation of the control switches while driving could allow the plow to fall.*



### CAUTION

**Remove the plow when driving extended distances at temperatures above 40° F, the plow blocks enough airflow to the vehicle's radiator to cause it to overheat at temperatures above 40° F.**

2. DO Not exceed 45 m.p.h. when driving with the snow plow attached. Braking distance is increased and handling is impaired dramatically at speeds above 45 m.p.h.
3. Reduce speed when crossing railroad tracks or when road conditions deteriorate.
4. Never change blade angle or height while driving.
5. Position the blade out of the beam path of the headlights before driving.
6. Inspect plow and plow attaching hardware for wear or damage before transporting and beginning plow operations.

## Plowing Like A Pro



### WARNING

- **Never exceed 10 m.p.h. when plowing! Serious personal injury can result, as well as damage to equipment and property, if an unseen obstruction is encountered while plowing.**
- **Never plow with your head protruding from the vehicle side window. Serious head or neck injuries can result from sudden stops or coming into contact with tree branches, signs or other stationary objects.**

**FAILURE TO HEED CAN RESULT IN SERIOUS INJURY OR DEATH**



### WARNING

**Wear your seat belt! Contact with a hidden obstruction can cause serious personal injury from bodily contact within the vehicle cab or whiplash from sudden stops.**

**FAILURE TO HEED CAN RESULT IN SERIOUS INJURY OR DEATH**

1. Become familiar with the area to be plowed and mark potential hazards before the snow falls. Many immovable objects cannot be seen when covered with snow. Developing a plan early can save valuable time and equipment damage. Allow sufficient room to pile snow, out of the traffic area, with enough space for snow when the next storm comes.

2. Plow with the storm. The “Pros” are out early removing only several inches of snow at a time. Allowing snow to accumulate to unmanageable levels can cause difficult removal problems and can be costly in terms of “wear and tear” on equipment. The plow is not a “Ram or Bulldozer”. If used properly, it will give you many years of safe and reliable service.

3. Research municipal ordinances for restrictions on the disposal of snow. Many municipalities do not allow snow to be placed in roads or throughways.

## Using The Down Pressure (DP) Hydraulic System

The DP system was designed for removing hard packed snow from hard surfaces that have had traffic on them prior to being plowed.

The system should be turned OFF when plowing surfaces such as gravel, dirt, sand, etc., to prevent cutting into the surface being plowed.

*NOTE: For better clean up of hard-packed snow, raise the disc shoes so that the cutting edge of the blade comes into direct contact with pavement. Use the lowest possible gear to place maximum power behind the cutting edge.*

Activating the system applies down pressure to the down side of the hydraulic Raise Cylinder. This down pressure will force the blade through the hard-packed snow and down to the pavement. If down pressure decreases, (results if a valley or low spot is encountered by the blade), more down pressure is applied to lower side of the Raise Cylinder and the blade will follow the contour of the valley. When a hill or a high spot is encountered by the blade, the down pressure will be relieved on the down side of the Raise Cylinder, this will allow the blade to follow the contour of the hill without lifting the front of the vehicle off the ground.

## Clearing Driveways

*NOTE: For better clean up of hard-packed snow, raise the disc shoes so that the cutting edge of the blade comes into direct contact with pavement. Use the lowest possible gear to place maximum power behind the cutting edge.*

1. Head into driveway with the blade angled to plow snow away from buildings. Continue to widen drive path by rolling snow away from buildings on successive passes.

2. If there is a garage at the end of the driveway, plow to within several vehicle lengths of the garage. Then push as much snow as possible off the driveway.

3. With a raised straight blade, drive through remaining snow to building. Drop plow and “back-drag” snow away from garage door at least one and one-half vehicle lengths. Repeat as necessary.

4. Back vehicle to garage door and plow forward toward street, removing the remaining snow.

## Clearing Parking Lots



### CAUTION

Never pile snow more than 18" high. Excessive stacking of snow causes undue stress to the snowplow and components. Repeated loading of this nature may, in time, result in the failure of certain components which are designed to protect the snowplow and vehicle from major damage.

*NOTE: For better clean up of hard-packed snow, raise the disc shoes so that the cutting edge of the blade comes into direct contact with pavement. Use the lowest possible gear to place maximum power behind the cutting edge.*

1. "Back drag" areas in front of buildings and near walls then work away from buildings towards the outer edges of the lot.

2. Plow a single path down the center in the longest direction.

*NOTE: Stacking snow; As the "stacking" location is approached, begin raising the plow to facilitate the ride-up onto the stack.*

3. Angle plow toward the exterior sides, and continue with successive passes until area is cleared and snow is "stacked" around outer edges. If snow is too deep to clear in the above manner, clear main traffic lanes as much as possible and stack snow at selected intermediate positions.

## Mounting Snow Plow To Vehicle



### WARNING

- Ensure Engine is OFF and set parking brake before mounting snow plow to vehicle, vehicle movement, equipment failure or inadvertent operation of the control switches during installation could result in serious injury.

- NEVER place fingers in A-frame or mount lug holes to check alignment. Sudden motion of the plow could severely injure a finger.

**FAILURE TO HEED CAN RESULT IN SERIOUS INJURY OR DEATH**



### WARNING

#### VEHICLES EQUIPPED WITH AIR BAGS!

Certain Vehicles equipped with Air Bags cannot be equipped with Snow Plows because of the possibility of the Air Bag being deployed if the Snow Plow hits an obstruction. Before attempting to install a Snow Plow on a vehicle equipped with Air Bags, consult with the vehicle manufacturer to be sure that Snow Plow operation will not result in inadvertent deployment of the vehicle air bag.

#### FAILURE TO HEED CAN RESULT IN SERIOUS INJURY OR DEATH

1. Position vehicle as close as possible to plow assembly. Set parking brake and turn ignition switch off.
2. Align A-frame and vehicle mounting lugs and install two (2) lower outboard pivot Hitch Pins. Install Lynch Pins into Hitch Pins to secure them in place. (See Figure 1-1)

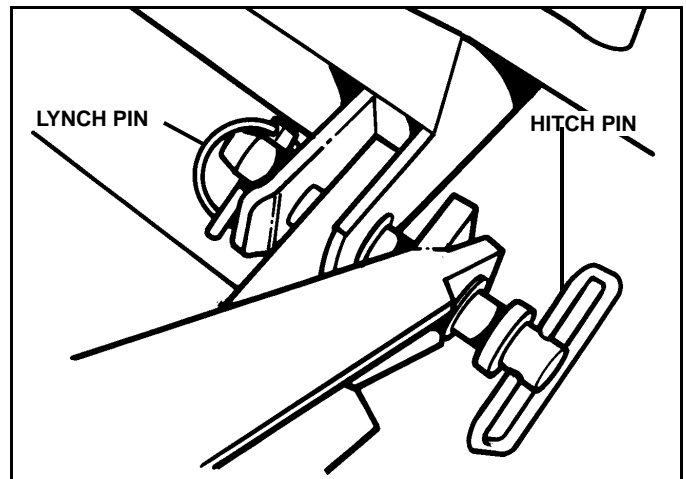

Figure 1-1

3. Remove the protective cover from the snow plow wiring harness and store it inside the vehicle for installation when the plow is removed.

8. Connect accessory light wiring harness.

## Installing The Transport Lock Clamp



### WARNING

Always install the Transport Lock Clamp when the plow is raised and the operator is not engaged in plowing operations. Equipment failure or inadvertent operation of the control switches while driving could allow the plow to fall, resulting in serious injury.

### FAILURE TO HEED CAN RESULT IN SERIOUS INJURY OR DEATH

1. Raise the plow to the full UP position.
2. Turn ignition switch OFF and apply the emergency brake.



### WARNING

Ensure ignition switch is OFF before installing or removing the Transport Lock Clamp. Equipment failure or inadvertent operation of the control switches could allow the plow to fall, resulting in serious injury.

### FAILURE TO HEED CAN RESULT IN SERIOUS INJURY OR DEATH

3. Remove the Pivot Pins from the Transport Lock Clamp and spread it apart.
4. Position the cylinder lock clamp around the exposed (chrome) portion of the Raise Cylinder and install the Pivot Pins.

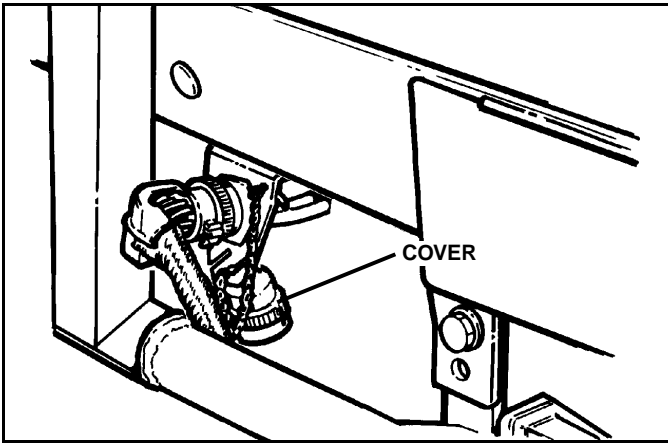

Figure 1-2

4. Remove the protective cover from the vehicle end of the wiring harness by rotating it counterclockwise and store it as shown in Figure 1-2, if it is chained to the harness Plug Bracket. If Plug is not chained to the bracket store the cover in the vehicle for future use.



### CAUTION

Never use pliers or any other tool to force the connector halves together.

5. Align the two harness connector halves, push the plow end connector onto the vehicle connector and rotate clockwise to lock.

6. Turn vehicle ignition switch to the accessory position and place raise/lower switch to lower position.

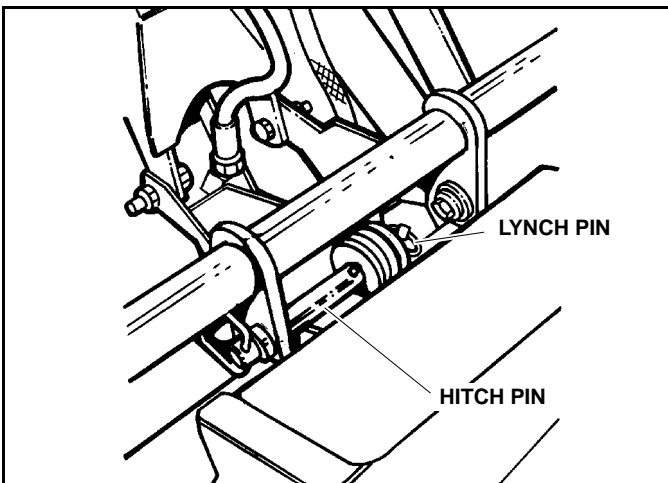

Figure 1-3

7. Align lift bar assemblies and install center pivot Hitch Pin, install Lynch Pin into Hitch Pin to secure it in place. (See Figure 1-3)

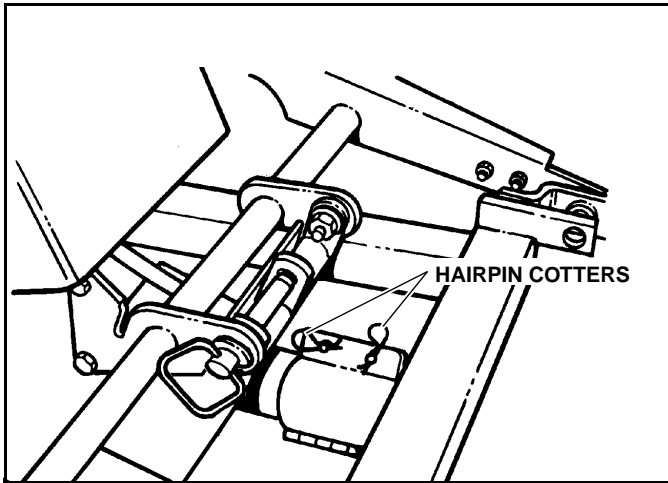

Figure 1-4

5. Install the Hairpin Cotters Into the Pivot Pins. (See Figure 1-4)

## Removing Snow Plow From Vehicle

1. Drive vehicle to the desired snow plow storage area. It is recommended that the plow be stored in a dry, protected area.

*NOTE: Plow should be thoroughly cleaned of all grime and road salt before it is put into storage.*

2. Straighten and lower plow assembly.
3. Put vehicle in park and turn off engine.



## WARNING

- Ensure engine is OFF and parking brake is set before removing snow plow from vehicle. Vehicle movement, equipment failure or inadvertent operation of the control switches during removal could result in serious injury.

- Ensure all personnel are clear of the area surrounding the plow storage location before angling or lowering the plow to prevent serious injury.

**FAILURE TO HEED CAN RESULT IN SERIOUS INJURY OR DEATH**

4. Turn vehicle ignition switch to accessory position only.

5. Put control box toggle switch in “down” or “float” position, this is done to allow the “down” valve to remain activated which will allow the snow plow Raise Cylinder to collapse allowing easy removal of the Hitch Pins.

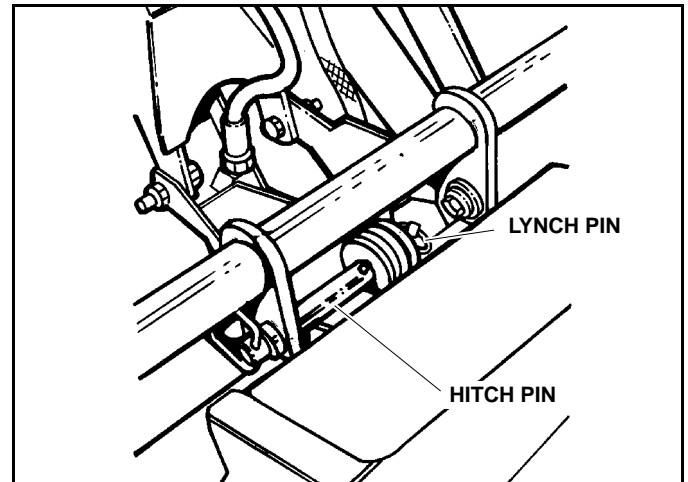

Figure 1-5

6. Remove Lynch Pin from center Pivot Hitch Pin and pull upward on bell crank-lift bar assembly until Pivot Hitch Pin can be easily removed. (See Figure 1-5)



## WARNING

**Keep hands and feet clear of blade and A-Frame when detaching plow. Moving or falling assemblies could result in serious injury.**

**FAILURE TO HEED CAN RESULT IN SERIOUS INJURY OR DEATH**

7. Rotate the outer collar of the electrical quick disconnect plug counterclockwise to unlock, then pull snow plow end of plug out of connector.

*NOTE: Place protective metal cover on the vehicle half of the quick disconnect and place the plastic storage cover (normally kept in the vehicle) on the snow plow half of the wiring harness connector. Tuck the snow plow end of the plug in an area of the snow plow where it is not exposed to potential damage such as crushing.*



## CAUTION

Never use pliers or any other tool to separate the wiring harness connector halves.

8. If Plow is equipped with auxiliary light kit, disconnect wiring harness and coat terminals of wiring harness plugs with dielectric grease.

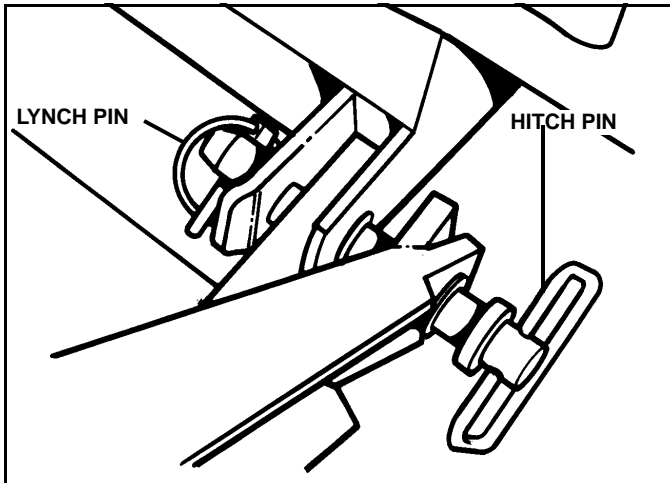

Figure 1-6

9. Remove the two (2) lower, outboard Pivot Hitch Pins. (See Figure 1-6)

10. Pull Snow plow assembly away from vehicle.

*NOTE: To avoid corrosion during storage, coat the exposed (chrome) portion of the lift and angle cylinders with a light grease.*

# TROUBLE SHOOTING GUIDE

## Introduction

Whenever service is necessary, your local dealer knows your plow best and is interested in your complete satisfaction. Return your snow plow to your local dealer for Maintenance service or any other assistance you may require. If you are unable to do so, this trouble Shooting Guide should help you determine the problem. Also, there are Repair Manuals available from your local dealer. However, before attempting the servicing of your plow, you should possess good mechanical abilities and a total understanding of the mechanism.

5. Check for external leakage at cylinders, hoses and power unit.

6. Check the voltage at the coils which operate the solenoid valves to be sure that the voltage at the coils is a minimum of 9-1/2 volts DC.



## CAUTION

**First read all warning instruction, the safety messages, and directions before attempting any adjustments or repairs to your unit!**

PLEASE: Before calling parts and service personnel be certain that:

1. You have read this guide carefully and are certain that all of the suggestions pertaining to your problem have been attempted.

2. You have the following information available.

- A. Date snow plow was originally installed.
- B. Power Pack Model Number.
- C. Power Pack Serial Number.
- D. Controller Serial Number.
- E. Blade Model Number.
- F. Blade Serial Number.
- G. Pump Serial Number.

This information should be recorded on page 2 of this Owners Manual.

## Trouble Shooting-Quick

### Reference General

1. Check to see that vehicle ignition switch is "on" or in "accessory" position.

2. Check, and replace if necessary, accessory fuse in vehicle fuse panel.

3. Check all wiring to be sure that battery terminals are clean and connections to battery, circuit breaker, solenoid, switches and all connectors on plow harness are clean and tight.

4. Check oil level in hydraulic system reservoir.

# TROUBLESHOOTING

PROBLEM	PROBABLE CAUSE	CORRECTIVE ACTION
Motor will not run	Motor brushes worn/commutator worn or dirty	Refer to dealer
	Seal between motor and pump damaged allowing oil to enter motor housing	Refer to dealer
	Circuit breaker failed	Refer to dealer
	Motor solenoid failed	Refer to dealer
	Motor seized	Refer to dealer
Motor continues to run and will not shut-off	Wires shorted out at solenoid or switch shorted out (raise, right, left)	Refer to dealer
Blade will not lift (motor runs)	Hydraulic fluid level low	See Maintenance section
	Raise/lower switch shorted out	Refer to dealer
	Improper main pressure relief valve pressure setting or debris causing valve to stick	Refer to dealer
	Breather cap plugged	See Maintenance section
	Lower solenoid valve stuck in lower position	Refer to dealer
	Raise cylinder binding	Refer to dealer
	Pick-up tube filter plugged	See Maintenance section
	Worn/failed pump	Refer to dealer
	Motor to pump coupler worn/failed	Refer to dealer
	Pick-up tube is not submerged in fluid	See Maintenance section
	Down pressure valve stuck partially shifted	Refer to dealer
Blade lifts slowly	Hydraulic fluid level low	See Maintenance section
	Breather cap plugged	See Maintenance section
	Improper main relief pressure setting or debris causing valve to stick.	Refer to dealer
	Pick-up tube filter plugged	See Maintenance section
	Improper oil viscosity for outside air temperature, unit not at normal operating temperature	See Maintenance section
	Flow control orifice incorrectly installed	Refer to dealer
	Weak system pump	Refer to dealer
	Low battery voltage	Refer to dealer
	Cylinder packing over torqued or dry	Refer to dealer
	Down pressure valve stuck partially shifted	Refer to dealer



# TROUBLESHOOTING

PROBLEM	PROBABLE CAUSE	CORRECTIVE ACTION
Unit lifts but does not hold - first action.	Dirt in check valve or lower solenoid valve	Cycle raise and lower system to flush debris
	Lower solenoid valve sticking	Cycle raise and lower system to un-stick valve
Unit lifts but does not hold- Second action.	Dirt or debris in check valve	Refer to dealer
	Check valve spring broken	Refer to dealer
	Lower solenoid valve sticking or stuck	Refer to dealer
	Seals, O-ring(s) on lower solenoid valve damaged	Refer to dealer
	Current available at lower solenoid without switch function	Refer to dealer
	Piston seals leaking on raise cylinder	Refer to dealer
Unit will not lower (Down pressure switch OFF)	Plugged breather cap	See Maintenance section
	Low or no current available at lower solenoid	Refer to dealer
	Lower solenoid valve sticking or stuck	Refer to dealer
	Lower solenoid coil inoperative	Refer to dealer
	Raise cylinder damaged allowing movement in one direction only	Refer to dealer
	Flow control orifice plugged	Refer to dealer
Unit will not lower Or Unit will not apply Down pressure (Down pressure switch ON)	Motor not running	Refer to dealer
	Down pressure valve stuck partially shifted	Refer to dealer
	Lower solenoid valve sticking or stuck	Refer to dealer
	Inoperative down pressure, pressure switch	Refer to dealer
	Inoperative down pressure solenoid/valve	Refer to dealer
	Down pressure relief valve setting to low	Refer to dealer
	Down pressure toggle switch (in control box) inoperative	Refer to dealer
	Broken wire/ open circuit in down pressure electrical circuit	Refer to dealer
Blade will not angle (motor runs)	Hydraulic fluid level low	See Maintenance section
	Crossover pressure relief valve setting too low	Refer to dealer
	Spool valve sticking or stuck	Refer to dealer
	Low or no current available at angle solenoid	Refer to dealer
	Angle solenoid coil inoperative	Refer to dealer
	Angle cylinder binding or bent	Refer to dealer
	Pick-up tube not submerged in fluid	See Maintenance section
	Crossover relief valve sticking or stuck	Refer to dealer

# TROUBLESHOOTING

PROBLEM	PROBABLE CAUSE	CORRECTIVE ACTION
Unit angles very slowly	Hydraulic fluid level low	See Maintenance section
	Crossover relief valve sticking or stuck	Refer to dealer
	Crossover relief valve pressure setting too low	Refer to dealer
	Improper oil viscosity for outside air temperature, unit not at normal operating temperature	See Maintenance section
	Spool valve sticking or stuck	Refer to dealer
	Damaged cylinder	Refer to dealer
	Cylinder packing improperly torqued or dry	Refer to dealer
Unit angles in one direction only	Spool valve sticking or stuck	Refer to dealer
	Crossover relief valve sticking or stuck	Refer to dealer
	Angle solenoid coil inoperative	Refer to dealer
	Low or no current available at angle solenoid	Refer to dealer
	Crossover relief valve pressure setting too low	Refer to dealer
	Angle cylinder binding	Refer to dealer
Unit does not hold angle. Note: This problem is usually noted when pushing snow or when plow is being transported.	Crossover relief valve pressure setting too low	Refer to dealer
	Crossover relief valve sticking or stuck	Refer to dealer
	Spool valve sticking or stuck	Refer to dealer
Fluid leaking at pump assembly	Hydraulic fittings not torqued properly (too tight, too loose)	Refer to dealer
	O-rings between valve block and endhead are worn/missing or not seating properly	Refer to dealer
	O-rings between endhead and reservoir worn or not seating properly	Refer to dealer
	Reservoir over-full	See Maintenance section
	O-ring on solenoid adaptor plate damaged	Refer to dealer
	Endhead cracked	Refer to dealer
	Valve body cracked	Refer to dealer
	Pump shaft seal leaking	Refer to dealer
	Drain plug loose/ over torqued fracturing reservoir	Refer to dealer
	Lower valve O-ring leaking	Refer to dealer
	U-valve mounting Cap Screws loose	Refer to dealer
	Reservoir fasteners loose	Refer to dealer

# TROUBLESHOOTING

<b>PROBLEM</b>	<b>PROBABLE CAUSE</b>	<b>CORRECTIVE ACTION</b>
Fluid leaking at down pressure valve	Hydraulic fittings not torqued properly	Refer to dealer
	Pressure switch improperly torqued	Refer to dealer
	Relief valve improperly torqued	Refer to dealer
	Down pressure valve improperly torqued	Refer to dealer
	Damaged O-rings on pressure switch, fittings, valves	Refer to dealer

# MAINTENANCE

## General

- Before operating, perform a thorough visual inspection of the equipment. Look for fluid leaks, cracked, bent or broken components, loose nuts, bolts or attachments and proper fluid levels.

- A clean hydraulic system is essential to long pump life and proper performance.

- When adding oil to the reservoir, wipe the area around the filler port clean before removing the breather cap. Use clean oil and a clean funnel, (DO NOT use a cloth or rag to strain the oil).

**IMPORTANT:** Hydraulic unit comes from factory charged with Type 5606. If additional oil is added it must be compatible with Type 5606. If another type of oil has been used in the system the same type of oil must be used for topping off system.

- The operational environment for snow plows is an extremely harsh and corrosive one.

- Ensure all electrical connections are clean and tight.

- To prevent rust from forming, clean and repaint exposed metal surfaces.

- NEVER operate the equipment with the protective covers or guards removed.

## Break In Period

During the first few hours of operation the Plow will go through a break in period during which mating surfaces of the A-Frame and Swing Frame pivots will settle in. After 15 to 20 hours of operation check for free play of the A-Frame and Swing Frame Pivot.

To check for free play:

- raise the plow and install the transport lock. See "Installing The Transport Lock Clamp" on page 10.
- push down on end of blade, either right or left side, as far as it will go
- using a tape measure, measure and record the distance from the ground to the bottom edge of the wear strip
- Pull upwards on the same end of the plow until edge of blade is raised as far as it will go
- measure and record the distance from the ground to the bottom edge of the wear strip
- Subtract the two measurements to determine the amount of free play between the Swing Frame Pivot and the A-Frame

*NOTE: Allowable free play range is 1/2" to 1-1/2". If free play exceeds this range it must be adjusted using the following steps.*

To remove any excessive free play:

- remove the 3/8" Cap Screw and Lock Nut which holds the Lock Plate to the Pump Platform (See Figure 2-2)
- tighten the Pivot Bolt Nut (typically 1/6 to 1/3 turn, one or two flats)
- replace the Lock Plate and secure with the 3/8" Cap Screw and Lock Nut.

## Periodic Inspection

After approximately every 20 hours of operation perform the following inspections procedures:

1. Inspect the plow assembly including the Subframe assembly for any damage or excessive wear. Also inspect all fasteners to insure that they are properly tightened. If any fasteners are loose re-tighten to the proper torque (Refer to the Torque Specification chart in this manual). Also carefully inspect adjacent area for damage or wear as well as carefully inspecting all adjacent fasteners for proper torque.

2. Apply a small amount of light oil to the Hitch Pins and pivots, to Pivot Pins between the Blade Assembly and the Swing Frame, between Lift and Swing Cylinder pivot Pins and the Lift Linkage Pivots.

3. Check for excessive free play between the A-Frame and Swing Frame Pivot. See "Break In Period" on page 18. If there is excessive free play adjust the Swing Frame Pivot Pin as described in the "Break In Period" section on page 18 of this manual.

*NOTE: If wear is noticed between the A-Frame and Swing Frame apply a good quality Anti-Seize lubricant to this area.*

## Hydraulic Cylinders

To avoid corrosion during storage, coat the exposed (chrome) portion of the lift and angle cylinders with a light grease.

## Electrical Quick Disconnect Plug

Install protective covers on quick disconnect ends to prevent corrosion from forming on terminal ends during storage or when plow is disconnected from vehicle.

## Polycarbonate Blade Care

- **DO NOT** use abrasive or highly alkaline cleaners on Polycarbonate Blade.
- Never scrape Polycarbonate Blade with squeegees, razor blades or other sharp instruments.
- Benzene, gasoline, acetone or carbon tetrachloride should never be used on Polycarbonate Blade.
- **DO NOT** clean Polycarbonate Blade in hot sun or at elevated temperatures.

## Polycarbonate Blade Cleaning Instructions

Wash with a mild soap or detergent and luke-warm water using a clean cloth or soft sponge. Dry thoroughly with a chamois or moist cellulose sponge to prevent water spots.

## Service Intervals

It is recommended that the fluid in the hydraulic system be changed once a season.

## Fluid Requirements

**IMPORTANT:** Hydraulic unit comes from factory charged with Type 5606. If additional oil is added it must be compatible with Type 5606.

*NOTE: Type 5606 oil is rated to – 60° F, when Type 5606 is not available Exxon UNIVIS J13 or equivalent may be used.*



## CAUTION

- Using the proper oil increases the life expectancy of the most critical part of your plow; the Hydraulic power unit.
- Failure to use the proper oil can cause extensive damage to the power unit, seals and hydraulic rams.

## Changing Oil and Cleaning Filter Screen



## CAUTION

Using the proper oil increases the life expectancy of the most critical part of your unit; the Hydraulic power unit.

*NOTE: We recommend cleaning the filter screen and magnet at every oil change, this will help ensure maximum life and maximum performance from the pump assembly.*



## WARNING

- Allow the system to cool down before draining oil or handling system components. Serious burns can result from contact with hot oil.
- Never disconnect any hydraulic line or fitting with the unit in the raised position. Always lower the unit and relieve pressure before removing any lines or caps.

**FAILURE TO HEED CAN RESULT IN SERIOUS INJURY OR DEATH**

1. Remove the plow from the vehicle. See “Removing Snow Plow From Vehicle” on page 11.
2. Remove the pump cover.

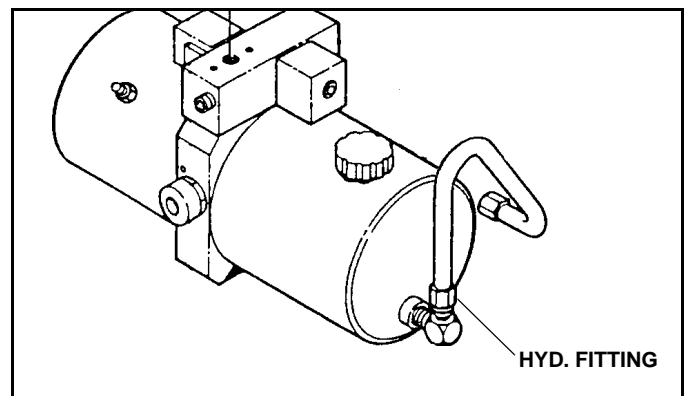

**Figure 2-1**

3. Disconnect hydraulic tube from fitting on end of reservoir. (See Figure 2-1)

4. Carefully drain oil from reservoir into a suitable container and discard in a approved waste oil disposal site.

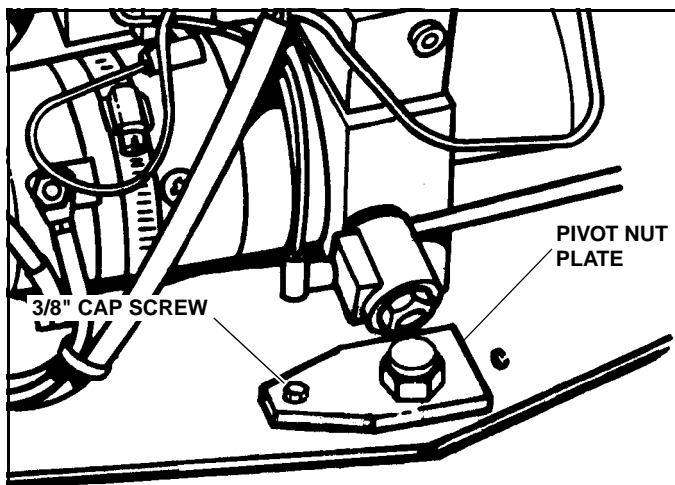

**Figure 2-2**

5. Remove 3/8" Cap Screw securing Pivot Nut Plate to Motor Mounting Plate.(See Figure 2-2)

6. Remove Nut from 1" Pivot Bolt.(See Figure 2-2)

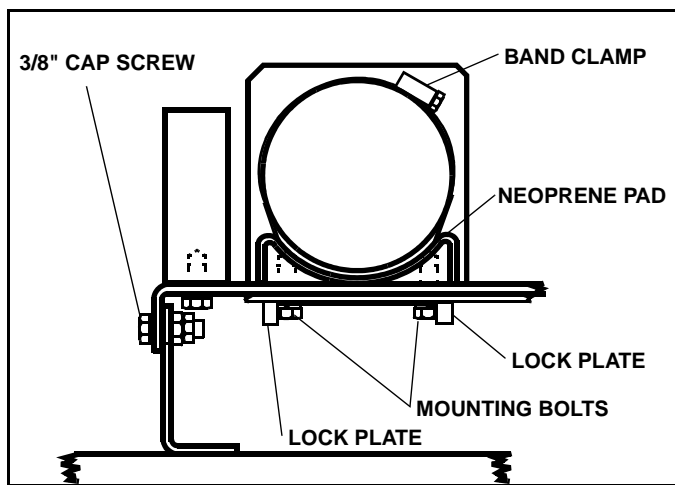

**Figure 2-3**

7. Remove two 3/8" Cap Screws securing Pump unit to A-Frame.(See Figure 2-3)

8. Loosen Band Clamp.(See Figure 2-3)

9. Tilt Power unit up and locate lock plate retaining mounting bolts. Flatten tabs. (See Figure 2-3)

10. Remove two 3/8" Cap Screws securing Pump unit to frame.(See Figure 2-3)

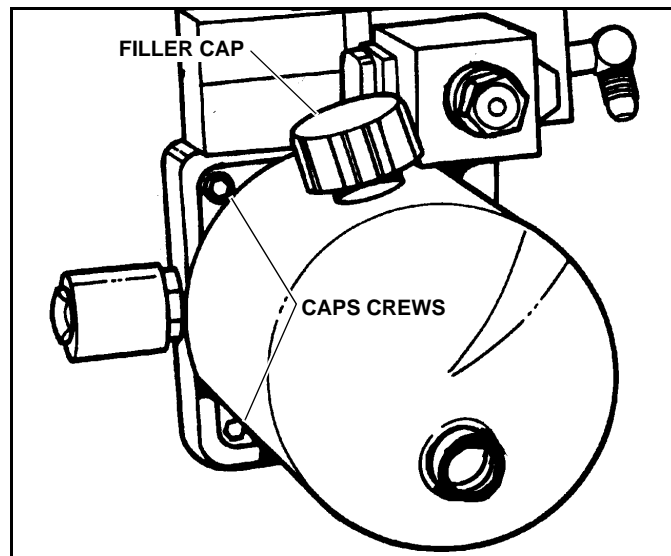

**Figure 2-4**

11. Remove the filler/breather cap from the reservoir. (See Figure 2-4)

12. Remove the four Cap screws securing the oil reservoir to the pump assembly and remove the oil reservoir. (See Figure 2-4)

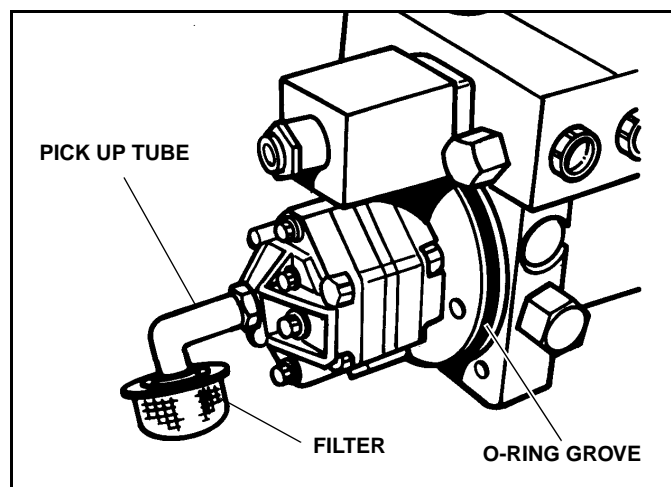

**Figure 2-5**

13. Unscrew the filter screen (hold it by the metal cover, not by the screen) and clean it with a suitable solvent. Blow dry with low pressure compressed air from the inside.

14. Carefully reinstall the filter screen. Tighten it by hand to avoid damaging the threads of the nylon pick-up tube.

15. Visually check that the pickup tube and filter face down (See Figure 2-5) if not, rotate the pickup tube until it is correctly positioned.

16. Clean the reservoir inside and out with a suitable solvent. Carefully remove any metal particles from the magnet inside the reservoir.

17. Inspect the O-ring seal for damage, replace if needed, lubricate with fresh oil and reinstall reservoir carefully to avoid damaging the O-ring. Tighten Cap Screws to 4-6 lb-ft. (See Figure 2-4)

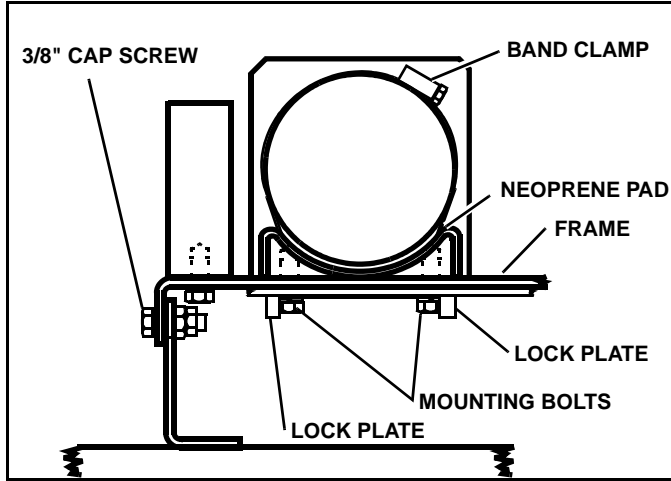

Figure 2-6

18. Position the Hydraulic control unit on the frame. Apply LOCTITE™ 262 (Red) on the two (2) 3/8" Cap Screws and insert through Lock Plate, frame and into endhead. Torque Cap Screws to 30-32 lb-ft. (See Figure 2-6)

**IMPORTANT:** After Cap Screws have been torqued bend end of Lock Plate over tight against two flats of each Cap Screw head. (See Figure 2-6)

*NOTE: make sure Neoprene Pad is located between power unit and mount. (See Figure 2-6)*

- 19. Tighten Band Clamp with screw driver to 40 lb-in.
- 20. Place Power Unit assembly in place on A-Frame. Apply LOCTITE® 262 (Red) to two 3/8" Cap Screws and torque to 35 lb-ft.
- 21. Place Lock Nut, with LOCTITE® 262 (Red), on end of Cap Screws and torque to 35 lb-ft.



**CAUTION**

**LOCTITE® 262 (Red) must be used on the 3/8" Bolts and Lock nut!**

**LOCK NUT MUST NOT BE OMITTED.**

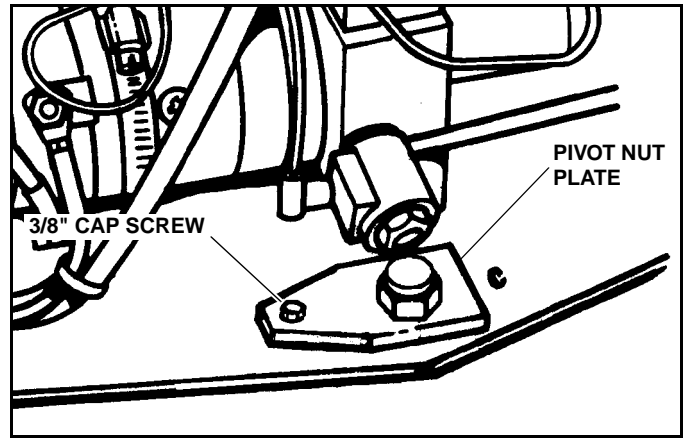

Figure 2-7

22. Reinstall 1" Pivot Bolt and tighten nut finger tight. (See Figure 2-7)

23. Install Pivot Nut Plate and secure with 3/8" Cap Screw. (See Figure 2-7)

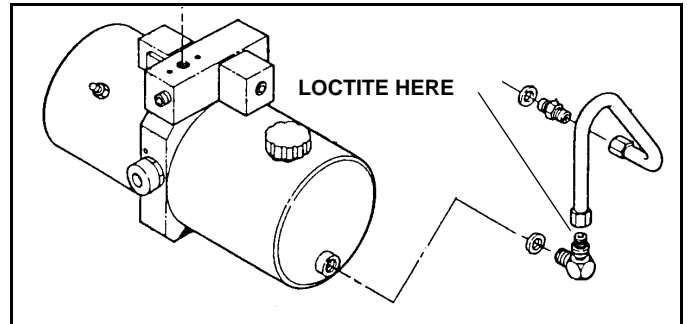

Figure 2-8

24. Reinstall Hydraulic Tube in end of reservoir. Use LOCTITE® 242 (Blue) on threads of fitting which mate with nuts on Hydraulic tube. (See Figure 2-8)

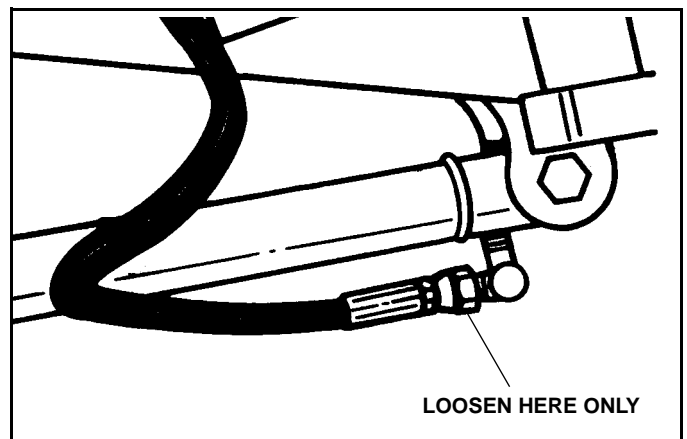

Figure 2-9

25. Mark hydraulic fittings for position and location on both Angle and Raise Cylinders and carefully disconnect them.

*NOTE: Do not loosen fitting in cylinder body. Loosen only at connection with hose.(See Figure 2-9)*

26. Manually work the two and Raise Cylinders through their entire range of motion in order to drain the fluid remaining in the cylinders.

27. Reconnect hydraulic fittings in their correct position and Torque to 20-25 lb-ft. If unit utilizes O-Ring and jam nut type connectors tighten jam nut to 12-15 lb-ft.

## CAUTION

**Do Not use Teflon tape or Pipe Dope On hydraulic fittings. These can dislodge and jam valves in the hydraulic system.**

28. Re-install plow on vehicle according to the instructions earlier in this manual.

29. Fill the hydraulic reservoir until the fluid level registers full on dip stick.

*NOTE: Vehicle must be parked on level ground and Plow must be in the lowered position in order to properly check the oil level with the Dipstick. Checking oil level with plow elevated will give wrong reading.*

30. Refer to plow operation instructions and operate the plow to purge all air from the hydraulic system.

31. Replenish the fluid in the reservoir until the fluid level registers full on dip stick.

32. Operate system and check for leaks, repair or tighten as necessary.

## Disk Shoe Adjustment

1. Raise the plow to the full UP position.
2. Place suitable blocking under plow to allow at least 10" of clearance to the ground.
3. Lower plow onto blocking.



## WARNING

**Keep hands and feet clear of blade and A-Frame when setting blocking and lowering plow. Moving or falling assemblies could result in serious injury.**

**FAILURE TO HEED CAN RESULT IN SERIOUS INJURY OR DEATH**

4. Turn ignition switch OFF and apply the emergency brake.

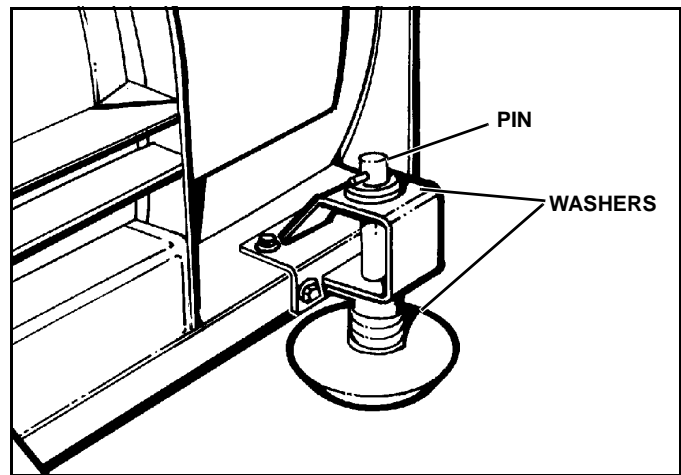

**Figure 3-10**

5. Adjust shoe assemblies by removing Shoe Mounting Pin and adding or subtracting washers on the top or bottom of the shoe mounting bracket. (See Figure 3-10)

*NOTE: Adjust shoe assemblies to meet road conditions. 1/4" to 1/2" off the ground for hard surfaces, 1" to 2" for gravel roads, etc.*

6. After the Disk Shoe position is properly adjusted, place washers on the Disk Shoe Stem - above the Disk Shoe Mounting Bracket, and below the Retaining Pin - to remove all up and down movement of the Disk Shoe in the Bracket. Failure to do this will result in excessive wear of the holes in the Disk Shoe Mounting Bracket and will also result in bending the Disk Shoe Stem.

## Cutting Edge

*NOTE: Cutting Edge must be replaced when it is worn to the bottom edge of the frame.*

1. Raise the plow to the full UP position.



2. Place suitable blocking under A-Frame of plow to allow at least 6" of clearance to the ground.

3. Lower plow onto blocking.

*NOTE: If Plow is equipped with Lexan Blade the blade must be retained prior to removing the Cutting Edge. This can be accomplished by using a pair of 6" C-clamps located at the center of the curved portion of the blade.*

4. Remove mounting bolts holding old Cutting Edge to blade. Discard old Cutting Edge and hardware.

5. Consult Parts Manual for proper replacement Cutting Edge.

6. Install new Cutting Edge using new hardware.



## WARNING

**Keep hands and feet clear of blade and A-Frame when setting blocking and lowering plow. Moving or falling assemblies could result in serious injury.**

**FAILURE TO HEED CAN RESULT IN SERIOUS INJURY OR DEATH**



## CAUTION

Cutting edge may be sharp. Handle with care to avoid injury.

### Trip Spring Adjustment

1. Lower plow to the full down position.

2. Insure that Blade Spring is installed as illustrated with open end of top loop facing vehicle. (See Figure 4-11)

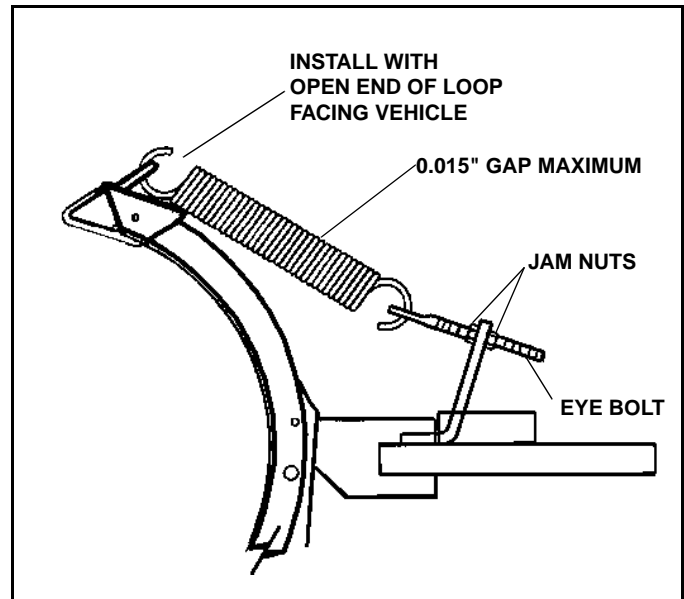

Figure 4-11

3. Adjust springs by loosening jam nuts on end of the eye bolts and turning opposing nut in proper direction. (See Figure 4-11)

*NOTE: Springs are properly adjusted when two or more coils allow a 0.010" feeler gauge to just pass between the separated coils. (A 3 x 5 post card is approximately the same thickness.)*







## CAUTION

- Do not overtighten springs. If more than 0.015" (1/64") gap appears between coil with plow at rest damage could occur to equipment during plowing.

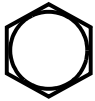
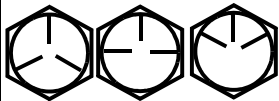
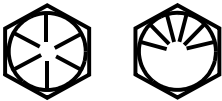
- Spring must be installed with open end of top loop facing vehicle. Bottom loop position will vary.

# TORQUE SPECIFICATIONS

SAE Grade and Head Markings	1 or 2 No Marks 	5 5.1 5.2 	8 8.2 
SAE Grade and Nut Markings	2 No Marks 	5 	8 

	Grade 1		Grade 2		Grade 5, 5.1 or 5.2		Grade 8 or 8.2	
	Lubricated <sup>a</sup>	Dry <sup>b</sup>	Lubricated <sup>a</sup>	Dry <sup>b</sup>	Lubricated <sup>a</sup>	Dry <sup>b</sup>	Lubricated <sup>a</sup>	Dry <sup>b</sup>
SIZE	lb-ft	lb-ft	lb-ft	lb-ft	lb-ft	lb-ft	lb-ft	lb-ft
8-32			14*	19*	22*	30*	31*	42*
10-24			21*	27*	32*	43*	45*	60*
1/4	2.8	3.5	4.5	5.5	7	9	10	12.5
5/16	5.5	7	9	11	15	18	21	26
3/8	10	13	16	20	26	33	36	46
7/16	16	20	26	32	41	52	58	75
1/2	25	31	39	50	63	80	90	115
9/16	36	45	56	70	90	115	130	160
5/8	50	62	78	100	125	160	160	225
3/4	87	110	140	175	225	280	310	400
7/8	140	175	140	175	360	450	500	650
1	210	270	210	270	540	675	750	975

DO NOT use these values if a different torque value or tightening procedure is given for a specific application.

Fasteners should be replaced with the same or higher grade. If higher grade fasteners are used, these should only be tightened to the strength of the original.

<sup>a</sup> "Lubricated" means coated with a lubricant such as engine oil, or fasteners with phosphate and oil coatings.

<sup>b</sup> "Dry" means plain or zinc plated without any lubrication

\* Values with asterisk are in lb-in.

# HYDRAULIC SCHEMATIC (Down Pressure System)

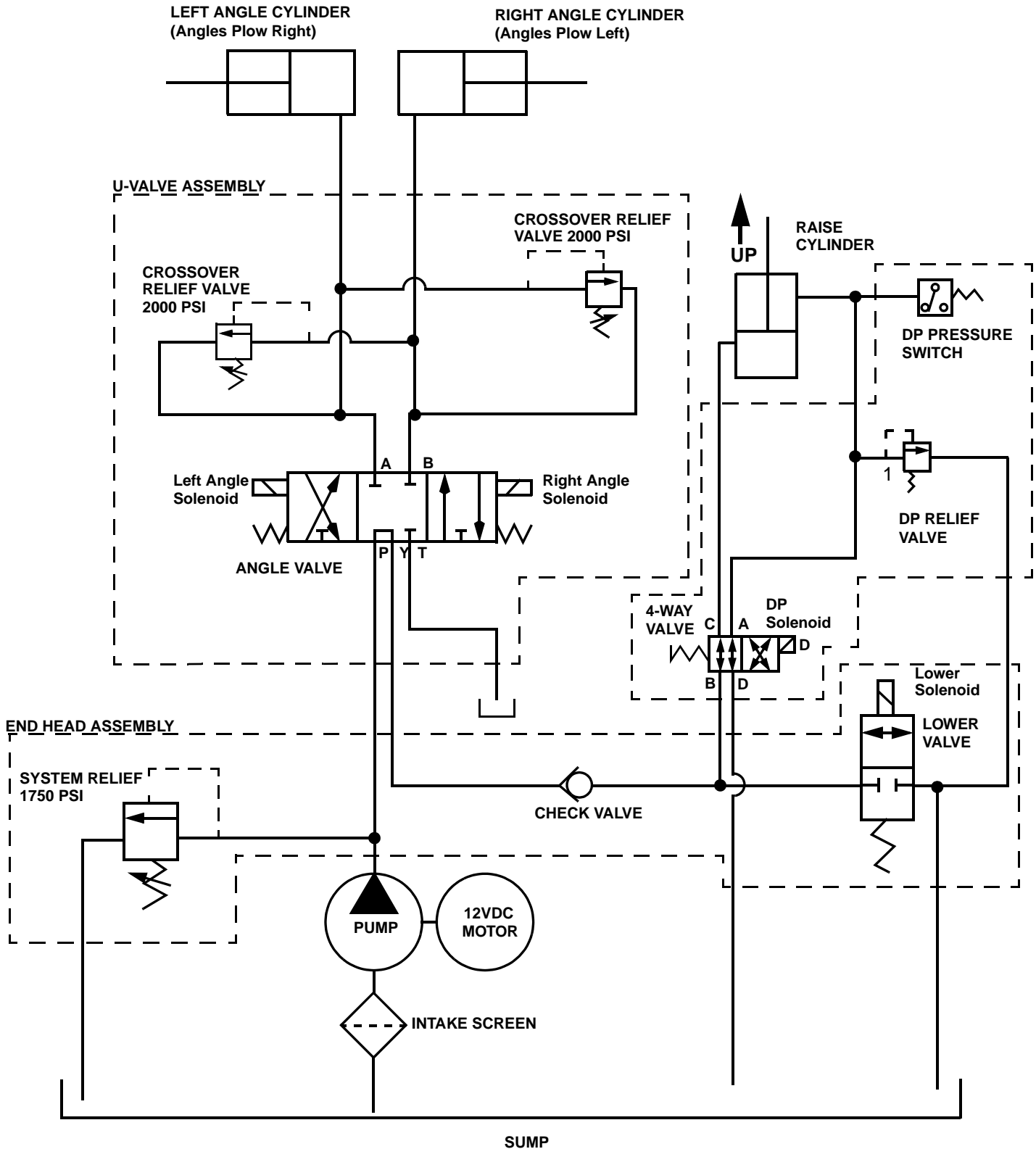

# WIRING SCHEMATIC ROCKER SWITCH STYLE (Down Pressure System)

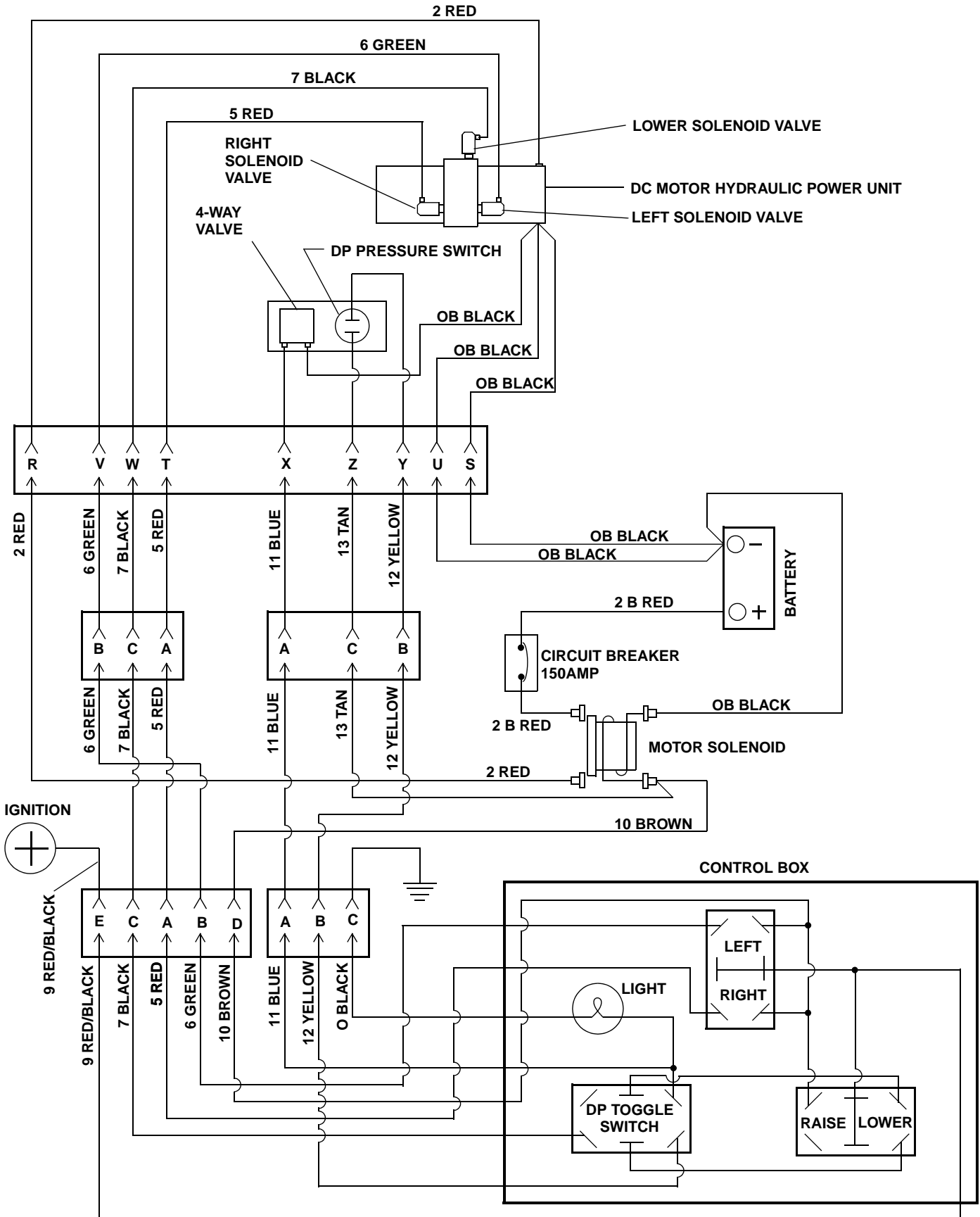

# WIRING SCHEMATIC JOY STICK STYLE (Down Pressure System)

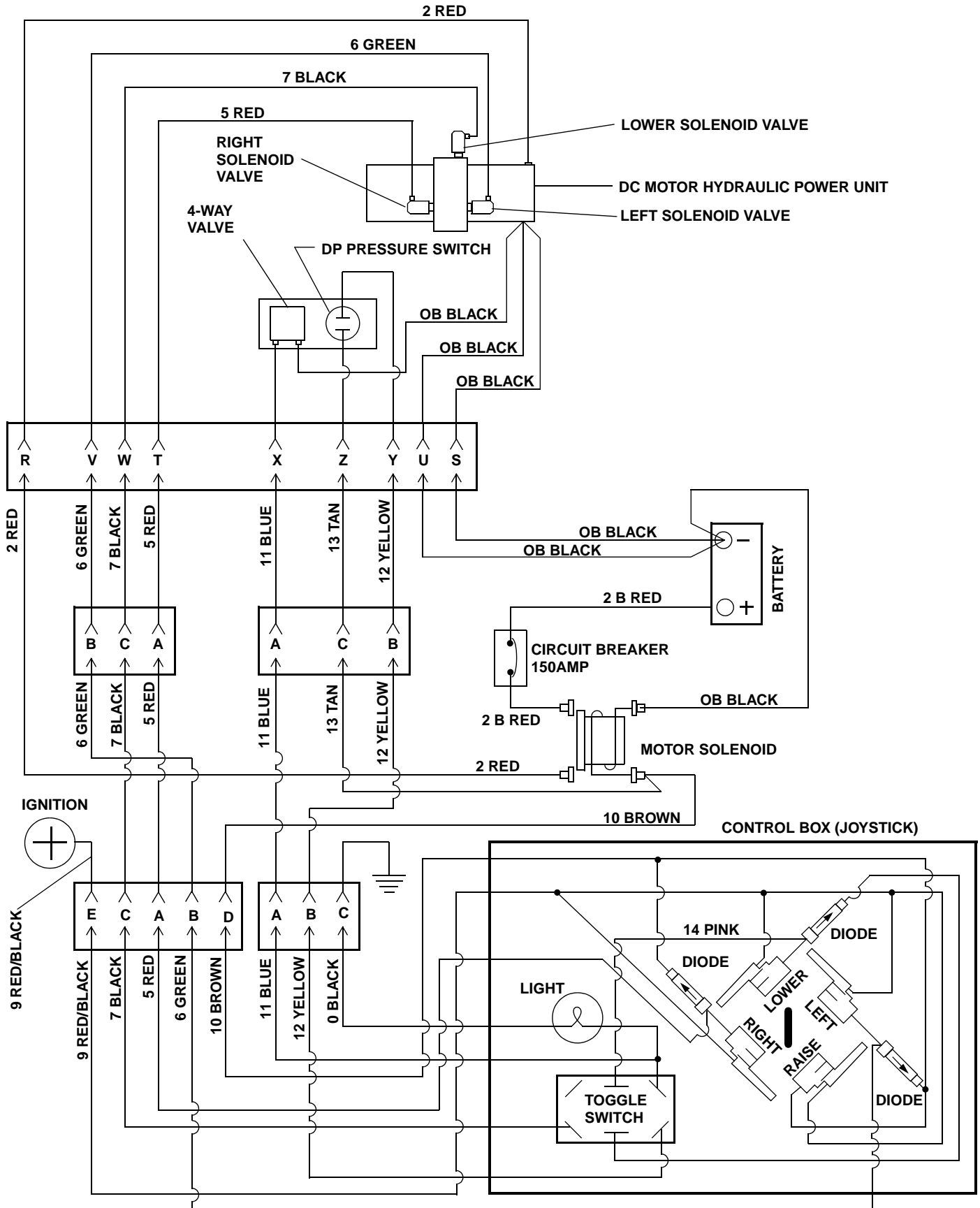

# Notes

# SNO-WAY PLOWS

## LIMITED ONE-YEAR WARRANTY

SNO-WAY Warrants to the original retail purchaser for a period of one (1) year from the date of delivery from an authorized SNO-WAY Dealer that your new SNO-WAY Plow is free from defects in materials and workmanship if properly set up and operated in accordance with the recommendations set forth in SNO-WAY's Set-up and Operator's Manuals. This warranty does not cover normal wear items such as shoes and wearstrips.

SNO-WAY Plows used by a dealer as a demonstrator shall be warranted only for the period of one (1) year from the date of delivery to said dealer and the first subsequent purchaser shall be entitled to the remaining warranty protection.

This warranty shall not apply to any item of equipment which has been repaired or altered outside the SNO-WAY factory or authorized SNO-WAY dealership or which has been subject to misuse, negligence or accident: neither shall it apply to equipment which has not been operated in accordance with SNO-WAY printed instructions or has been operated beyond the SNO-WAY'S recommended snow plow operating class.

**The Polycarbonate Moldboard is warranted to the original retail purchaser for a period of two (2) years from the date of delivery of the SNO-WAY Plow from an authorized SNO-WAY dealer and applies only to breakage of the Polycarbonate Moldboard. This warranty does not cover puncture, hazing, abrasion, yellowing, scratching or damage due to chemical attack. This warranty shall not apply to the polycarbonate moldboard which has been repaired or altered outside the SNO-WAY factory or authorized SNO-WAY dealership.**

To validate this warranty, your dealer and you must complete the enclosed Warranty Registration Card at time of purchase of the plow and return the Factory copy to SNO-WAY International, Inc. within ten (10) days following delivery of your new Plow.

To obtain warranty service, promptly return your Plow or any defective part at your expense to any authorized SNO-WAY dealer during the warranty period. Replacement or repair of defective or inadequate parts shall be performed without charge for labor or materials by such dealer at his regular place of business during regular business hours after inspection and determination that the warranty applies.

### EXCLUSIONS OF WARRANTY

Except as otherwise expressly stated herein, SNO-WAY makes no representation of warranty of any kind expressed or implied, including merchantability or fitness for particular purpose in respect to the equipment.

SNO-WAY shall not be liable for incidental or consequential damages for any breach of warranty, including but not limited to loss of use, inconvenience, rental or replacement equipment, loss of profits or other commercial loss.

No agent, employee or representative of SNO-WAY has any authority to bind SNO-WAY to any affirmation, representation or warranty concerning its equipment except as specifically set forth herein.

Certain limitations expressed herein are excludable in accordance with provisions of local law. Such limitations shall be deemed struck if such local law is applicable. All other limitations and provisions shall continue to apply.

**SNO-WAY INTERNATIONAL, INC.**

---

**SNO-WAY® INTERNATIONAL, INC.**



©1999 Sno-Way®  
International