

SNO-WAY®

SNOW & ICE CONTROL EQUIPMENT

ASSEMBLY & INSTALLATION INSTRUCTIONS

**MEGABLADE™ VEHICLE MOUNT KIT
99100964**

**TO FIT
1999 - 2007 FORD F250 - F550 SUPER DUTY SERIES 4X4**

Sno-Way®, Down Pressure® and EIS® are registered trademarks of Sno-Way International, Inc.
ProControl™, MegaBlade™, V-Wing™, E-Z Switch™, Revolution™, MaxAdjust™, SpeedLock™, and QuickJack™
are trademarks of Sno-Way International, Inc.

©2009 Sno-Way® International

97101516B



1. THINK SAFETY, ALWAYS WEAR SAFETY GLASSES WHEN PERFORMING THE OPERATIONS PRESCRIBED IN THESE INSTRUCTIONS
2. READ ALL INSTRUCTIONS CAREFULLY BEFORE ATTEMPTING INSTALLATION
3. BEFORE BEGINNING WORK MAKE SURE TO SET PARKING BRAKE AND CHOCK WHEELS



MINIMUM VEHICLE RECOMMENDATIONS

Heavy Duty Alternator
 Heavy Duty Battery
 Manufacturers Snow Plow Package

NOTE: On some vehicles it may be necessary to use a form of load booster to decrease the vehicle's front suspension sag with the snow plow in place. This can be accomplished with the use of supplementary air bags, booster springs, or similar load boosting devices. Since there are different load boosting devices available, it will up to the customer/end user to decide and purchase the product to suit the application, and not the responsibility of Sno-Way International, Inc.

ASSEMBLY TOOLS NEEDED

Drill Bits	1/4", 17/32", 21/32"
Impact Sockets	7/16" – 1-3/8"
Impact Sockets, Metric	10mm – 18mm
Wrenches	7/16" – 1-3/8"
Wrenches, Metric	10mm - 18mm
Torque Wrench	
Center Punch and Hammer	
Rat Tail Pry Bar	
Rubber Bands	

INSTALLATION NOTES

NOTE: Items designated "DS" refer to the Driver Side or Left Hand Side of the vehicle. Items designated "PS" refer to the Passenger Side or Right Hand Side of the vehicle.

1. Unless otherwise specified, mount all Subframe Components to vehicle before tightening any hardware.
2. It is recommended that LOCTITE®, or similar thread locking product, be used on ALL mounting hardware (i.e. Nuts, Cap Screws, Bolts, etc.).
3. Vehicle should be parked on a level surface with a normal vehicle load on the FRONT suspension.
4. Items in parentheses () refer to quantity required for this step. Items in parentheses with a pound sign (#) indicate the part number as found in the parts list on the last page of this document.
 Example: (2) 5/8" - 11 x 2" Cap Screws (#10).
5. It may be necessary to relocate license plate holder. Check state and local laws for placement, if applicable.

1. 99-04 vehicles are equipped with a detachable BlockerBeam™ that is attached to the frame horns behind the bumper. Disconnect the rubber air deflector from the BlockerBeam™, then unbolt and remove the BlockerBeam™ and tow hooks from the truck frame. Retain, with hardware, for future use if sub-frame is removed. **BlockerBeam™ must be reinstalled if the sub-frame is ever removed, and must be transferred when vehicle is sold or traded.**
2. Remove the bumper by first removing any electrical cords attached to bumper (diesel engine and vehicles with fog lamps). Remove the bumper fasteners and save with BlockerBeam™.

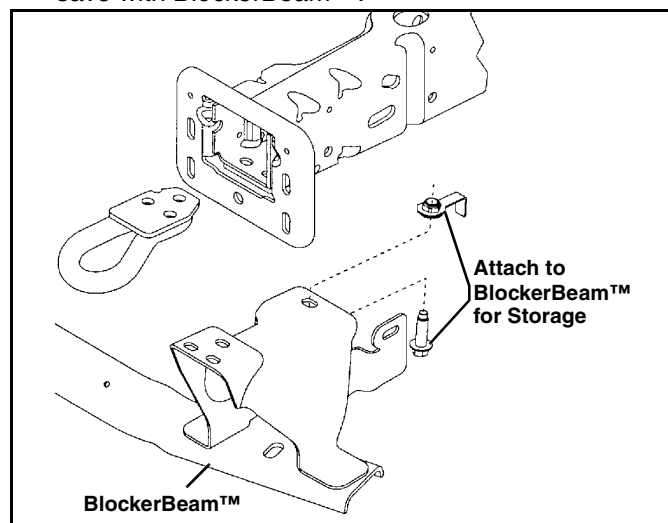

MOUNTING INSTRUCTIONS



WARNING

According to the Ford Owner Guide, removing the BlockerBeam™ without installing snow plow attachment hardware may affect air bag deployment in a crash. DO NOT operate the truck unless either the BlockerBeam™ or snow plow attachment hardware is installed on the vehicle! FAILURE TO HEED CAN RESULT IN INJURY OR DEATH!

3. Remove the four sway bar bracket bolts and remove the retained nut plates from the sway bar bracket. Allow the sway bar bushings and U-bracket to separate from the vehicle frame.

NOTE: On 99-04 model years it may be necessary to raise the body from the suspension to allow additional clearance between the truck frame and the leaf springs. Also Note (Reference illustration that follows): For 99-04 Side Weldments will require hole slotting to fit 1/2" bolt in the rear of the brackets. Install the Side Weldments (#2 DS, #3 PS).

4. Insert (4) 1/2" Carriage Bolts (#15) in slots on the inward side of the tow hooks and secure the Side Weldments with (8) 1/2" flat Washers (#12) and (4) 1/2" Nylock Nuts (#13).

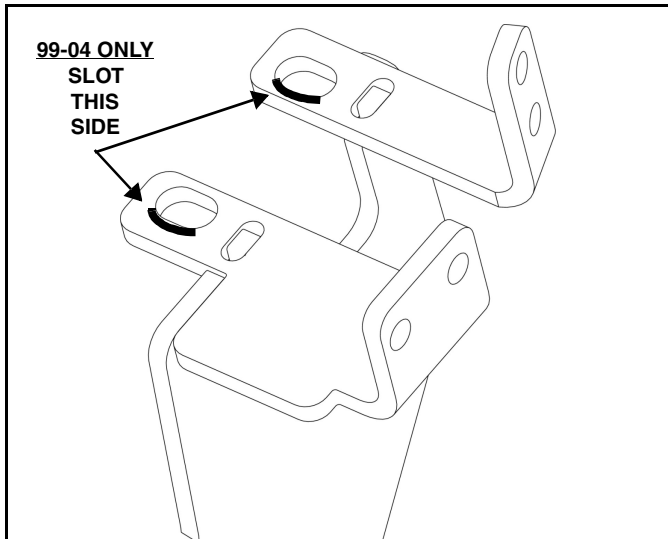

5. Position the Outer Plates (#4 LH, #5 RH) over the top of the truck frame and secure to the Side Weldments (#2 and #3) with (4) 1/2"-13 x 1-1/2" Cap Screws (#16) and (4) 1/2" Nylock Nuts (#13). Tighten the Nylock Nuts for proper alignment in the following steps:

- a. Insert (4) 1/2"-13 x 2" Cap Screws (#17), (8) 1/2" Hardened Flat Washers (#18) and (4) Nylock Nuts (#13) in the bottom of the truck frame. Using the Side Weldment brackets as a template, center punch and drill 1/4" pilot holes in any holes that do not line up with a pre-existing hole in Side Weldments and Outer Plates. Remove Side Weldments and Outer Plates and drill holes to 17/32."

WARNING

Beware of brake and fuel lines secured to inside wall of frame rails when drilling holes in vehicle frame!
FAILURE TO HEED CAN RESULT IN INJURY OR DEATH!

NOTE: For 05-07 model years ensure that Side Weldments are between the bottom of the sway bar bracket and the U-brackets. To take up the gap between sway bar block and the frame, insert (2) Spacers (#7).

- b. Re-install Side Weldments and Outer Plates with hardware specified above. Loosely attach the Side Weldments using hardware specified in Step 5a.

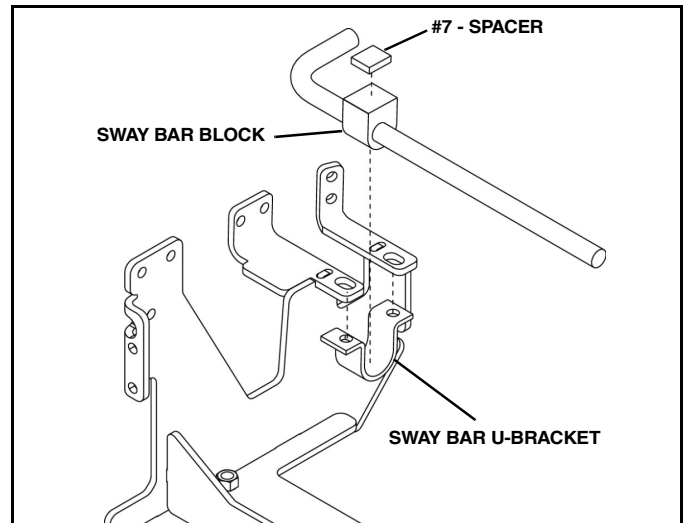

- c. Insert into DS frame rail (4) Handle Bolt Weldments 1/2"-13 x 1-1/2" x 15" (#6) with (4) 1/2" Flat Washers (#12) into the frame through the rear most holes drilled in Step 5a, Secure using (4) 1/2" Flat Washers (#12) and (4) 1/2" Nylock Nuts (#13). For 05-07 vehicles, secure (1) bumper bracket (#8) to the bumper using (1) 1/2"-13 x 1-1/2" Cap Screw (#16), (2) 1/2" Flat Washers (#12) and (1) Nylock Nut (#13).
 - d. Repeat Step 5c for PS components.
 - e. Insert (2) 1/2"-13 x 1-3/4" Cap screws (#11) and (2) Nylock Nuts (#13) (inside the frame) into the holes drilled on the outside of the frame rail for the outer plates located towards the front of the vehicle.
6. Install the Vehicle Receiver Member (#1 - Found in the Power Pack Assembly) to the DS and PS Side Weldments using (8) 5/8"-11 x 2-1/2" Cap screws (#9) and (8) 5/8" Hardened Flat Washers (#10) securing hardware loosely.
 7. Using the Torque Specification Chart that follows, torque all bolts, **starting at the rear** and working forward.

TORQUE SPECIFICATIONS FOR STANDARD MACHINE HARDWARE					
Bolt Size	GR.2 Dry	GR.5 Dry	GR.8 Dry	Metric Size	GR.8.8 Dry
1/4"	66*	9	12	M8	17
5/16"	11	17	25	M10	35
3/8"	20	30	45	M12	60
7/16"	32	50	70	M14	95
1/2"	50	75	110	M16	155
9/16"	70	110	150		
5/8"	100	150	220		
3/4"	175	260	380		
7/8"	170	430	600		
1"	250	640	900		

Note: These torque values are to be used for all hardware. Unless otherwise specified, all torque values must meet this specification.
Note: All torque values are in Ft.-Lbs unless otherwise stated
Note: *In-Lbs

8. Reinstall the bumper using the existing hardware at the frame horns and using (2) 1/2"-13 x 1-1/2" Cap Screws (#16), (4) 1/2" Flat washers (#12) and (2) 1/2" Nylock Nuts (#13) for bumper support brackets. Reattach any electrical cords removed during bumper removal.

REMEMBER After 5 to 10 hours of snowplow usage, re-torque all Cap Screws!

PARTS LIST

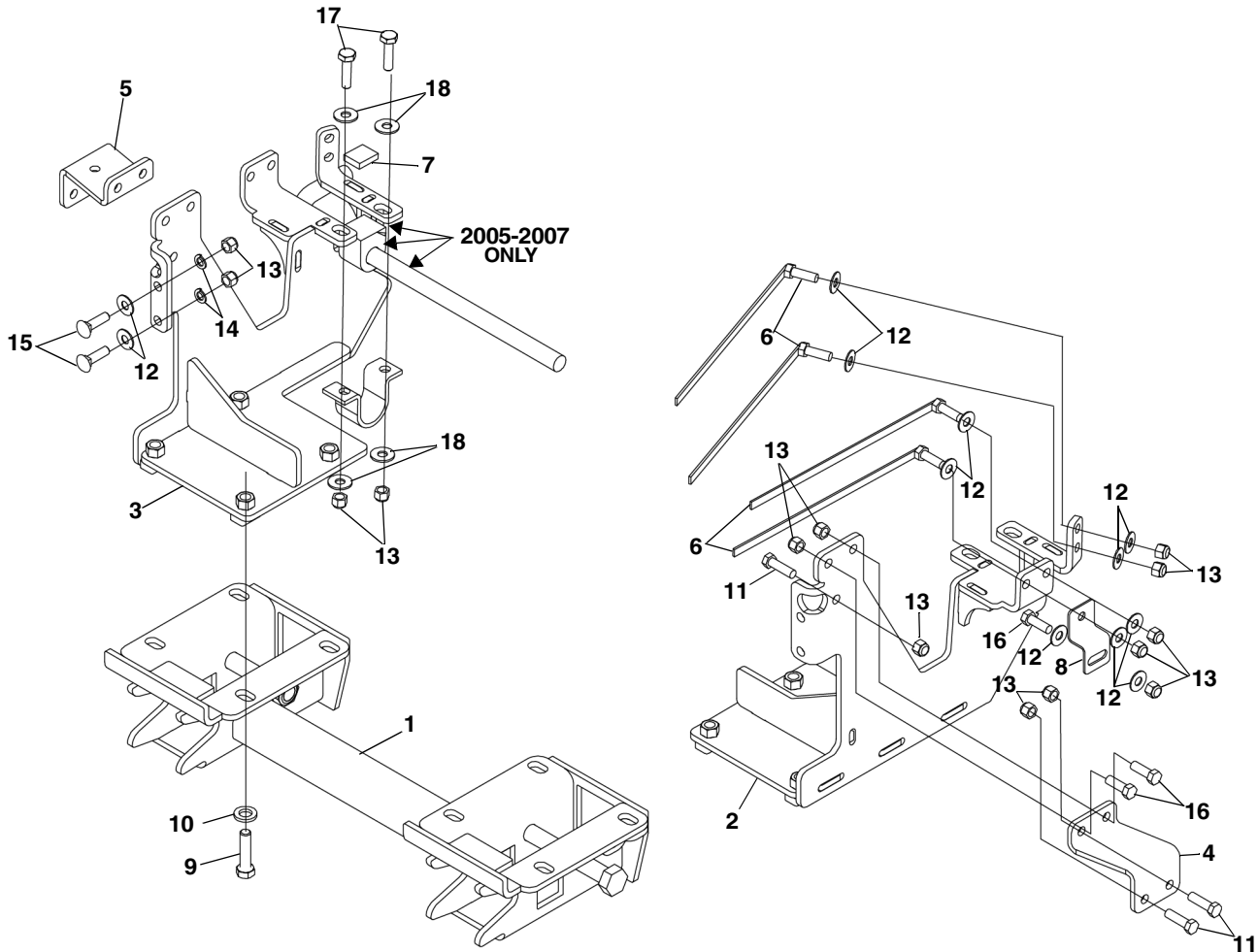

Note: It is recommended that LOCTITE®, or similar thread locking product, be used on ALL mounting hardware (i.e. Nuts, Cap Screws, Bolts, etc.).

ITEM	PART NO.	DESCRIPTION	QTY.
1	96112795*	Weldment, VRM (included in power pack)	1
2	96112944*	Side Weldment, DS.....	1
3	96112945*	Side Weldment, PS.....	1
4	96103546*	Plate Outer, LH	1
5	96103545*	Plate Outer, RH.....	1
6	96112384	Handle Bolt Weldment 1/2"-13 x 1-1/2" x15"	8
7	96112386*	Spacer (05-07 only)	2
8	96112385*	Bumper Bracket (05-07 only)	2
9	98009259	Hex Head Cap Screw, 5/8"-11x2-1/2"	8
10	98100446	Flat Washer, 5/8", .195/.170 Thick, Hardened	8
11	98100095	Hex Head Cap Screw, 1/2"-13x1-3/4"	6
12	98009011	Flat Washer, 1/2".....	20
13	98009013	Lock Nut, 1/2"-13, Nylock Insert	28
14	98009012	Lock Washer, 1/2"	4
15	98009171	Carriage Bolt, 1/2"-13x1-1/2"	4
16	98009010	Hex Head Cap Screw, 1/2"-13x1-1/2"	6
17	98100094	Hex Head Cap Screw, 1/2"-13x2"	4
18	98100176	Flat Washer, 1/2", A Wide Hardened	8

* Not Available As a Service Part

SNO-WAY® INTERNATIONAL, INC.



Hartford, WI 53027 USA
 Website: www.snoway.com
 ©2009 Sno-Way® International