

SNO-WAY®

SNOW & ICE CONTROL EQUIPMENT

ASSEMBLY & INSTALLATION INSTRUCTIONS

VEHICLE MOUNT KIT 99100860
FOR
29/32 PLOW SERIES ONLY

TO FIT
1994-2002 Dodge RAM BR2500, BR3500 4x4
1994-2002 Dodge RAM BR3500 Chassis Cab
(Single & Dual Rear Wheels)



Sno-Way® and EIS® are registered trademarks and Down Pressure™ is a trademark of Sno-Way International, Inc.



1. THINK SAFETY, ALWAYS WEAR SAFETY GLASSES WHEN PERFORMING THE OPERATIONS PRESCRIBED IN THESE INSTRUCTIONS
2. READ ALL INSTRUCTIONS CAREFULLY BEFORE ATTEMPTING INSTALLATION
3. BEFORE BEGINNING WORK MAKE SURE TO SET PARKING BRAKE AND CHOCK WHEELS



MINIMUM VEHICLE RECOMMENDATIONS

Heavy Duty Alternator(4X2, 4X4)
 Heavy Duty Battery (4X2, 4X4)
 Air-Adjustable Suspension Kit (4X2, 4X4)
 Manufacturers Snowplow Package (4X2, 4X4)

NOTE: On some vehicles it may be necessary to use a form of load booster to decrease the vehicle's front suspension sag with the snow plow in place. This can be accomplished with the use of supplementary air bags, booster springs, or similar load boosting devices. Since there are different load boosting devices available, it will up to the customer/end user to decide and purchase the product to suit the application, and not the responsibility of Sno-Way International, Inc.

ASSEMBLY TOOLS NEEDED

Drill Bits	1/4" - 1/2", 21/32" & 5/8"
Impact Sockets	7/16" - 1-3/8", 18mm
Wrenches	7/16" - 1-3/8", 18mm
Torque Wrench	
Center Punch and Hammer	
Clamping Device ("C" or bar type)	
Rat Tail Pry Bar	
Hacksaw	
Torx Bits	VT25, VT27

INSTALLATION NOTES

1. Unless otherwise specified, mount all Vehicle Mount Kit Components to vehicle before tightening any hardware.
2. It is recommended that **LOCTITE®**, or similar thread locking product, be used on ALL mounting hardware (i.e. Nuts, Cap Screws, Bolts, etc.).
3. Vehicle should be parked on a level surface with a normal vehicle load on the FRONT suspension.
4. Items in parentheses () refer to quantity required for this step. Items in parentheses with a pound sign (#) indicate the part number as found in the parts list on the last page of this document.
 Example: (2) 1/2"-13 x 1-1/2" Cap Screws (#7).
5. It maybe necessary to relocate license plate holder. Check state and local laws for placement, if needed.

remaining hole with (2) 1/2" x 4-1/2" Cap Screw (#16), (4) 1/2" Flat Washers (#10), and (2) 1/2" Nylock Nuts (#11). Flat Washers are used on both the Nut and Bolt sides. For later 1997 and newer vehicles, the hole will not be used.

NOTE: The following vehicles will require a Shim Plate (#6) between the rear holes on the left and right hand brackets and the vehicle frame: (See Figure 1.)

- Vehicles of less that 8800lbs GVWR
- Vehicles of 8800 lbs GVWR or greater manufactured before April 1996
- 4x2 Vehicles

MOUNTING INSTRUCTIONS

NOTE: The air dam may need to be cut for the Vehicle Mount Kit and Vehicle Center Member to be installed.

1. On one side, remove the two front bumper bolts and the stud plate from the bumper. In the top front hole, insert a 1/2" bolt (not supplied) and tighten securely with a standard nut. One of the existing vehicle bumper bolts will replace the 1/2" bolt after the Vehicle Mount Kit is installed. Repeat this procedure for the other side.
2. Install the Front Mtg Weldments, LH (#3) and RH (#2): Attach the Front Mtg Weldments (#2 and #3) to the outside of each side of the frame rails, re-installing the bumper support brackets with (2) 1/2"-13 x 1-1/2" Cap Screws (#7), (4) 1/2" Flat Washers (#10), and (2) 1/2" Nylock Nuts (#11). The Flat Washers are used on both the bolt and nut side. Use the previously removed bumper bracket bolts to secure through the center slot.
 On vehicles for early 1997 and prior, secure the

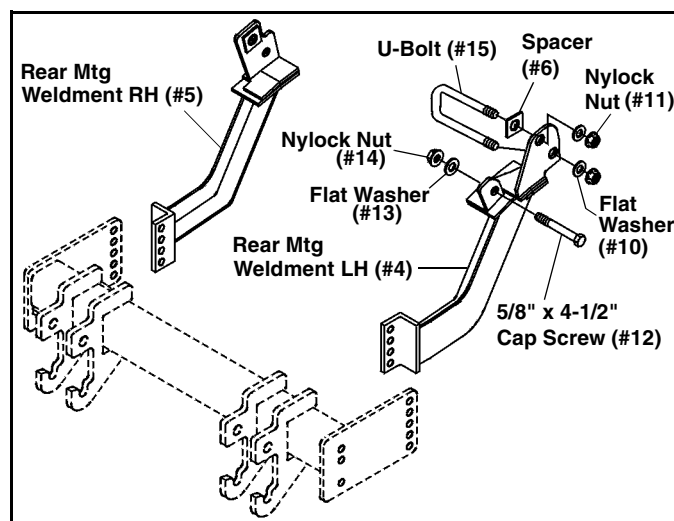

Figure 1

NOTE: Installation of Item #4 in some applications may be difficult, so extra time and drilling may be needed.

- Position the Rear Mtg Weldment, LH (#4), to align the mounting holes:
 - Front holes: An existing hole for a 5/8" Cap Screw will be present. On some vehicles the power steering pump mounting bolt can be used. On other vehicles, a small existing hole will be present. If the small hole is present, use the hole in the bracket as a template to drill out the hole in the vehicle frame to 21/32". (See Figure 2.)
 - Rear holes: One of the two rear holes should align with the 1" hole in the vehicle frame rail. On some models there is no 1" hole to accommodate the 1/2" U-Bolt (#15). In this case, use the rear holes in the Rear Mtg Weldment as a template to drill a 5/8" hole in the vehicle frame.

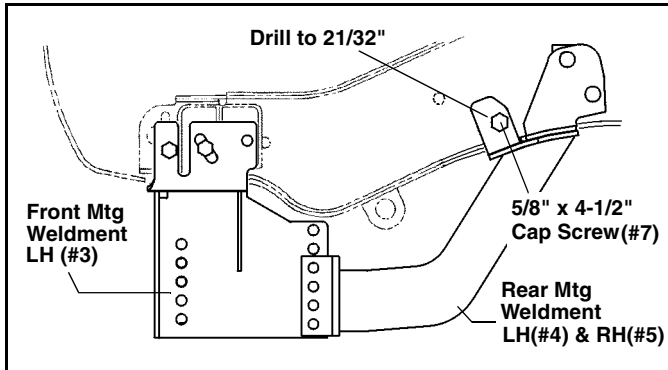

Figure 2

- Secure (1) Rear Mtg Weldment (#4) to the vehicle frame with (1) 1/2" U-Bolt (#15). Loop the 1/2" U-Bolt through the 1" holes in the outer face of the vehicle frame. (Hint: To insure the bolt doesn't fall into the frame, hold it in place with a rubber band.) Position the two back holes of the Rear Mtg Weldment over the U-bolt, secure with (2) 1/2" Flat Washers (#10) and (2) 1/2" Nylock Nuts (#11). Hold the Rear Mtg Weldment to the bottom of the vehicle frame and push towards the rear of the vehicle. Finger tighten the bolts. Secure the front hole with (1) 5/8"-14 x 4-1/2" Cap Screw (#12), (1) 5/8" Flat Washer (#13), and (1) 5/8" Nylock Nut (#14).
- Position the Rear Mtg Weldment (#5), to check the mounting alignment. (See Step 3, if holes need to be drilled). Loop the 1/2" U-Bolt (#15) through the 1" holes in the outer face of the frame. (Again, secure with a rubber band to insure the U-Bolt doesn't fall into the frame.) Position the Rear Mtg Weldment (#5) on the U-Bolt and secure with (2) 1/2" Flat Washers (#10), and (2) 1/2" Nylock Nuts (#11).
- Attach the Vehicle Center Member (#1) to the front set of vertical holes in the Front Mtg Weldments LH (#3) and RH (#2), using (4) 1/2"-13 x 1-1/2" Cap Screws (#7), (2) 1/2" Lock Washers (#9), and (2) 1/2" Nylock Nuts (#11). Attach the Vehicle Center Member to the Front Mtg Weldments, LH and RH, and to the Rear Mtg Weldments, LH and RH, through the rear set of vertical holes, using (4) 1/2"-13 x 2" Cap Screws (#8) and (4) 1/2" Nylock Nuts (#11).

- Using the torque specification chart provided, torque all cap screws.
- Replace the 1/2" bolts installed in step 2 with the existing bumper bolts. Tighten to manufacturers specifications.

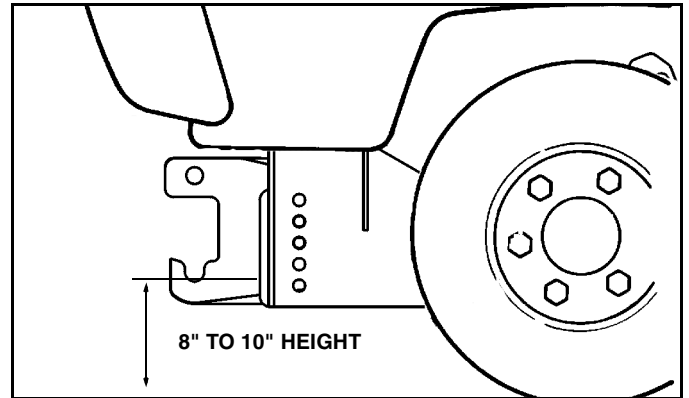

Figure 3

IMPORTANT: Height from the bottom of the lower pin slots on the Vehicle Mount Kit to the ground should be between 8" and 10" to insure proper operation. On some vehicles it may be necessary to use a form of load booster (See note page 1, Minimum Vehicle Recommendations).

TORQUE SPECIFICATIONS FOR STANDARD MACHINE HARDWARE

Bolt Size	GR.2 Dry	GR.5 Dry	GR.8 Dry	Metric Size	GR.8.8 Dry
1/4"	66*	9	12	M8	17
5/16"	11	17	25	M10	35
3/8"	20	30	45	M12	60
7/16"	32	50	70	M14	95
1/2"	50	75	110	M16	155
9/16"	70	110	150		
5/8"	100	150	220		
3/4"	175	260	380		
7/8"	170	430	600		
1"	250	640	900		

Note: These torque values are to be used for all hardware. Unless otherwise specified, all torque values must meet this specification.
 Note: All torque values are in Ft.-Lbs unless otherwise stated
 Note: *In-Lbs

REMEMBER After 5 to 10 hours of snowplow usage, re-torque all Cap Screws!

PARTS LIST

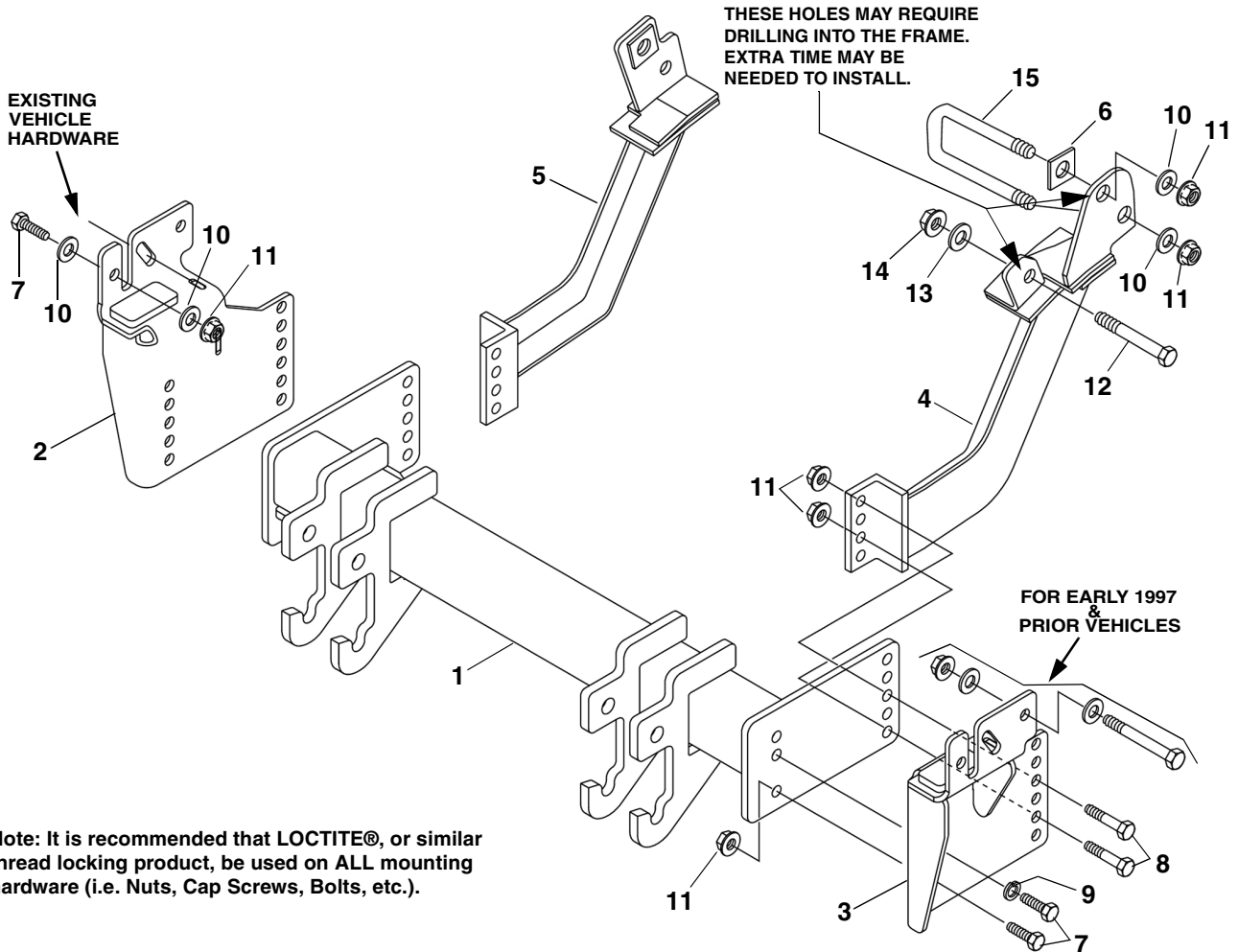

Note: It is recommended that LOCTITE®, or similar thread locking product, be used on ALL mounting hardware (i.e. Nuts, Cap Screws, Bolts, etc.).

ITEM	PART NO.	DESCRIPTION	QTY.
1	99100891	Vehicle Center Member (96108692)	1
2	96111717*	Front Mtg Weldment, RH.....	1
3	96111716*	Front Mtg Weldment, LH	1
4	96109116*	Rear Mtg Weldment, LH.....	1
5	96109117*	Rear Mtg Weldment, RH	1
6	96102702*	Plate Shim.....	2
7	98009010	Hex Head Cap Screw, 1/2"-13 x 1-1/2".....	6
8	98100094	Hex Head Cap Screw, 1/2"-13 x 2".....	4
9	98009012	Lock Washer, 1/2"	2
10	98009011	Flat Washer, 1/2".....	12
11	98009013	Nylock Nut, 1/2".....	14
12	98009111	Hex Head Cap Screw, 5/8"-11 x 4-1/2"	1
13	98009039	Flat Washer, 5/8".....	1
14	98009038	Nylock Nut, 5/8".....	1
15	98100271	U-Bolt, 1.2".....	2
16	98009055	Hex Head Cap Screw, 1/2"-13 x 4-1/2"	2

* Not Available As a Service Part

SNO-WAY® INTERNATIONAL, INC.



Hartford, WI 53027 USA
 Website: www.snoway.com
 ©2008 Sno-Way® International