



**Assembly
&
Installation Instructions**

**FOR
VEHICLE MOUNT KIT 99100872
USING
VEHICLE CENTER MEMBER 99100890**

**TO FIT
1999 - LATER Chevrolet 2500 Silverado 4x4 and 3500 Pickup 4x4
1999 - LATER GM 2500 Sierra 4x4 and 3500 Pickup 4x4**



1. **THINK SAFETY, ALWAYS WEAR SAFETY GLASSES WHEN PERFORMING THE OPERATIONS PRESCRIBED IN THESE INSTRUCTIONS**
2. **READ ALL INSTRUCTIONS CAREFULLY BEFORE ATTEMPTING INSTALLATION**
3. **BEFORE BEGINNING WORK MAKE SURE TO SET PARKING BRAKE AND CHOCK WHEELS**



MINIMUM VEHICLE RECOMMENDATIONS

Heavy Duty Alternator
 Heavy Duty Battery
 Manufacturer's Snow Plow Package

NOTE: On some vehicles it may be necessary to use a form of load booster to decrease the vehicle's front suspension sag with the snow plow in place. This can be accomplished with the use of supplementary air bags, booster springs, or similar load boosting devices. Since there are different load boosting devices available, it will up to the customer/end user to decide and purchase the product to suit the application, and not the responsibility of Sno-Way International, Inc.

ASSEMBLY TOOLS NEEDED

Drill Bits	1/4", 17/32" and 21/32"
Impact Sockets	7/16" – 1-3/8"
Impact Sockets, Metric	10mm – 18mm
Wrenches	7/16" – 1-3/8"
Wrenches, Metric	10mm - 18mm
Torque Wrench	
Rat Tail Pry Bar	
Center Punch and Hammer	

INSTALLATION NOTES

1. **Unless otherwise specified, mount all Vehicle Mount Kit Components to vehicle before tightening any hardware.**
2. **It is recommended that LOCTITE®, or similar thread locking product, be used on ALL mounting hardware (i.e. Nuts, Cap Screws, Bolts, etc.).**
3. Vehicle should be parked on a level surface with a normal vehicle load on the FRONT suspension.
4. Items in parentheses () refer to quantity required for this step. Items in parentheses with a pound sign (#) indicate the part number as found in the parts list on the last page of this document.
 Example: (2) 5/8"-11 x 1-1/2" Cap Screws (#7).
5. It maybe necessary to relocate license plate holder. Relocate under the driver's side headlight by drilling new holes in the bumper. Check state and local laws for placement, if needed.

Front Mtg Weldment with the existing lower tow hook hole on the bottom of the vehicle frame rail. Install (1) 1/2"-13 x 1-1/2" Cap Screw (#11), (1) 1/2" Lock Washer (#13) and (1) 1/2" Flat Washer (#16) through the Front Mtg Weldment flange and bottom of frame rail into (1) Nut Plate (#17), inserted into the frame rail from the front. Install (1) 1/2"-13 x 1-1/2" Cap Screw (#11), (1) 1/2" Lock Washer (#13) and (1) 1/2" Flat Washer (#16) through the top inside hole of the Front Mtg Weldment and the vehicle frame upper tow hook hole into (1) Nut Plate (#17), inserted into the frame rail from the front. The middle hole on the bottom of the frame should align with the middle hole of the Front Mtg Weldment flange. Using the front hole as a template, drill a 1/4" pilot hole, and then drill to 21/32" through the bottom of the truck frame; secure with (2) 5/8"-11 x 1-1/2" Cap Screws (#7) and (2) 5/8" Lock Washers (#8) into the Nut Plate (#5), which is inserted through the front of the frame rail. Repeat procedure for the Front Mtg Weldment, RH (#3).

MOUNTING INSTRUCTIONS

1. Remove the bumper with the air dam attached. Retain with hardware for replacement at the end of the installation. Typically, the front fascia or air dam of the vehicle will need to be modified to accommodate the Vehicle Mount Kit.
2. Remove splash shield from underneath the vehicle. It should be possible to reinstall the splash shield on the vehicle, above the Vehicle Center Member (#1). (Otherwise retain with hardware for future use.)
3. Remove the tow hooks and retain with hardware for re-installation, if applicable. (See NOTE following Item #4).
- 4a. **For 99-06 vehicles:** Align the top inside hole of the Front Mtg Weldment, LH (#2), with the existing upper tow hook hole on the inside of the vehicle frame rail, and align the rear hole in the horizontal flange of the

NOTE: For most applications from 99-06, the tow hooks have to be left off the vehicle in order to mount the plow. In some cases, the tow hooks can be re-installed. Re-install the tow hooks, if applicable, using M12-1.25 x 40 Cap Screws (#14) in the upper holes, and M12-1.25 x 40mm Cap Screws (#14) with 1/2" Lock Washers (#13) in the lower holes. (One each, per side).

procedure for the Front Mtg Weldment, RH (#3).

NOTE: For most applications from 07- Later, the tow hooks have to be left off the vehicle in order to mount the plow. In some cases, the tow hooks can be re-installed. Re-install the tow hooks, if applicable, using M12-1.25 x 40 Cap Screws (#14) in the upper holes. The hole for the lower horizontal tow hook hole may not be present in the Front Mtg Bracket, using the existing tow hook hole as a template, and secure with the M12-1.25 x 40mm Cap Screws (#14), (1) 1/2" Lock Washer (#13) and a 1/2" Flat Washer (#16).

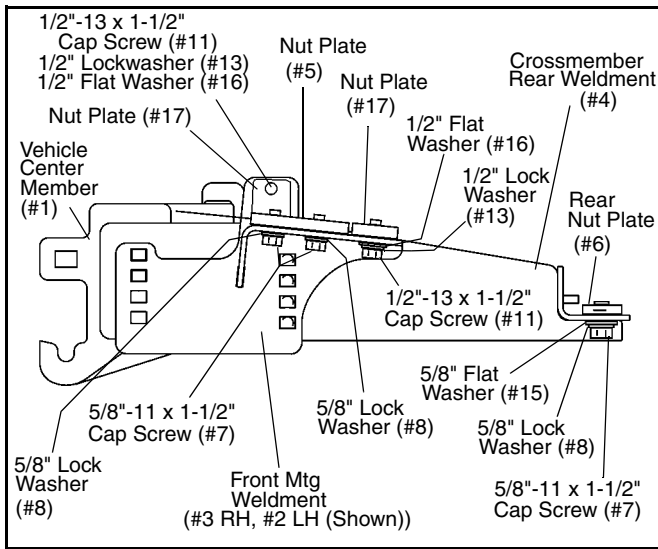

Components without tow hook re-installation.

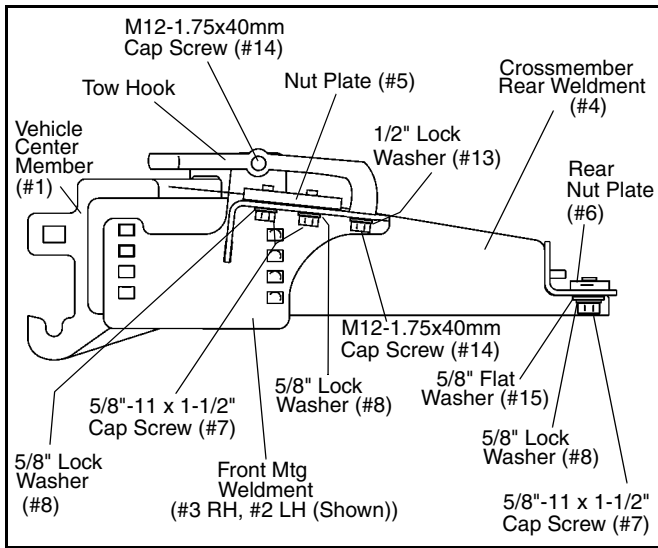

Components with tow hook re-installation.

4b. **For 07- Later vehicles:** Align the top inside hole of the Front Mtg Weldment, LH (#2), with the existing upper tow hook hole on the inside of the vehicle frame rail, and align the rear holes in the horizontal flange of the Front Mtg Weldment with the existing holes in the bottom of the frame rail. Insert (1) Nut Plate (#20) into the front of the frame and align with the rear two holes in the horizontal flange of the Front Mtg Weldment; secure with (2) 5/8"-11 x 1-1/2" Cap Screws (#7), (2) 5/8" Lock Washers (#8) and (2) 5/8" Flat Washers (#15). Secure the upper inside tow hook hole using (1) 1/2"-13 x 1-1/2" Cap Screw (#11), (1) 1/2" Lock Washer (#13) and (1) 1/2" Flat Washer (#16) into (1) Nut Plate (#17), inserted into the frame rail from the front. Using the front hole as a template, drill a 1/4" pilot hole, and then drill to 17/32" through the bottom of the truck frame; secure with (1) 1/2"-13 x 1-1/2" Cap Screw (#11), (1) 1/2" Lock Washer (#13) and (1) 1/2" Flat Washer (#16) into the Nut Plate (#17), which is inserted through the front of the frame rail. Repeat

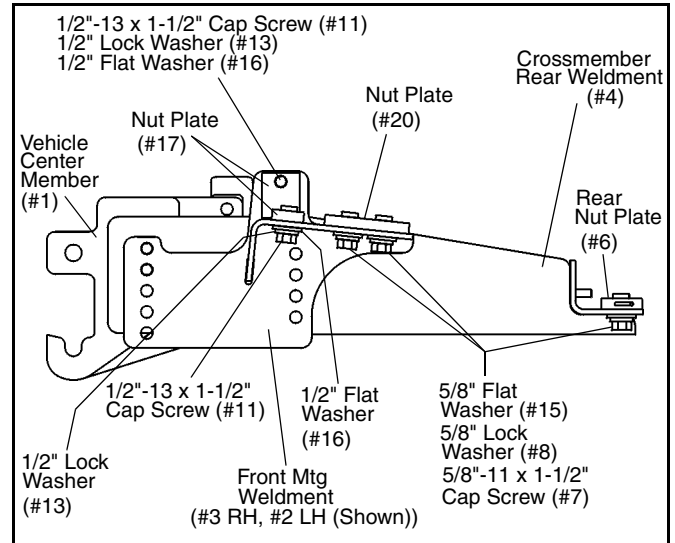

Components without tow hook re-installation.

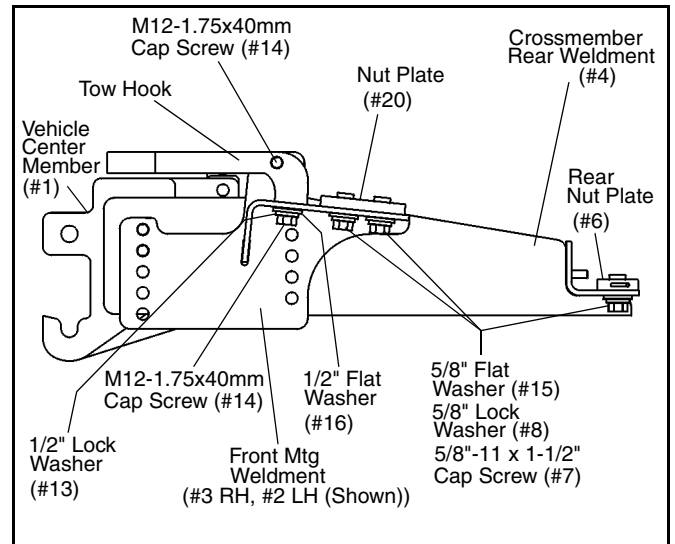

Components with tow hook re-installation.

5. Position the Crossmember Rear Weldment (#4) under the lip of the truck's cross frame. Secure the Crossmember Rear Weldment outer holes using (2) 5/8"-11 x 1-1/2" Cap Screws (#7), (2) 5/8" Lock Washers (#8), (2) 5/8" Flat Washers (#15) and (2) Rear Nut Plates (#6) to the vehicle frame. For the inner holes use the (2) M10-1.50 x 35mm Cap Screws

(#9), (2) 10 mm Lock Washers (#10) and (2) 1/2" Flat washers (#16).

6. Attach the Vehicle Center Member (#1) to the Front Mtg Weldments LH and RH (#2 & #3), using (8) 1/2"-13 x 1-1/2" Cap Screws (#11), (2) 1/2" Lock Washers (#13) in the threaded holes, and (6) 1/2" Nylock Nuts (#12).
7. Secure the Crossmember Rear Weldment (#4) to the Vehicle Center Member (#1) using (2) Spacer Plates (#19) (between the Crossmember Rear Weldment and the vehicle center members lugs), (4) 1/2"-13 x 1-3/4" Cap Screws (#18) (in the top and bottom hole in the lugs), (2) 1/2"-13 x 1-1/2" Cap Screws (in one of the middle holes) (#11), and (6) 1/2"-13 Nylock Nuts (#12).
8. Using the Torque Specification Chart given, torque all bolts starting at the rear and working forward.
9. Re-install the bumper onto the vehicle.

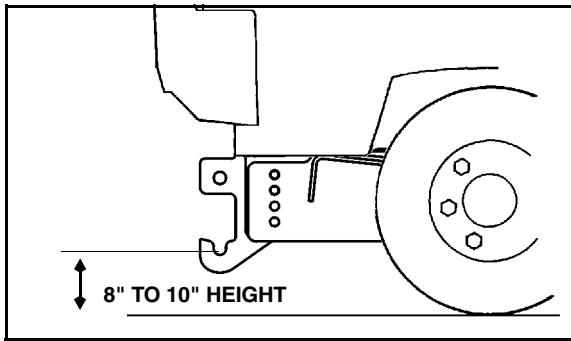

IMPORTANT: Height from the bottom of the lower pin slots on the Vehicle Mount Kit to the ground should be between 8" and 10" for proper operation.

TORQUE SPECIFICATIONS FOR STANDARD MACHINE HARDWARE					
Bolt Size	GR.2 Dry	GR.5 Dry	GR.8 Dry	Metric Size	GR.8.8 Dry
1/4"	66*	9	12	M8	17
5/16"	11	17	25	M10	35
3/8"	20	30	45	M12	60
7/16"	32	50	70	M14	95
1/2"	50	75	110	M16	155
9/16"	70	110	150		
5/8"	100	150	220		
3/4"	175	260	380		
7/8"	170	430	600		
1"	250	640	900		

Note: These torque values are to be used for all hardware. Unless otherwise specified, all torque values must meet this specification.
 Note: All torque values are in Ft.-Lbs unless otherwise stated
 Note: *In-Lbs

REMEMBER After 5 to 10 hours of snowplow usage, re-torque all Cap Screws!

PARTS LIST

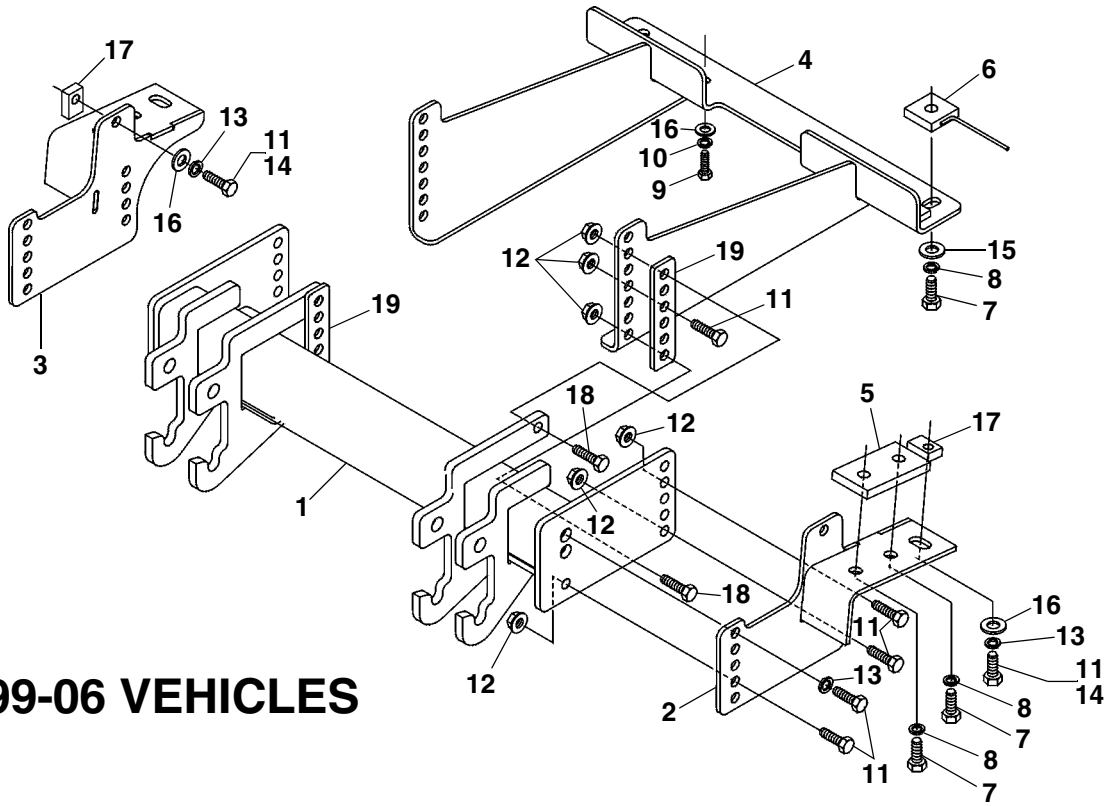

FOR: 99-06 VEHICLES

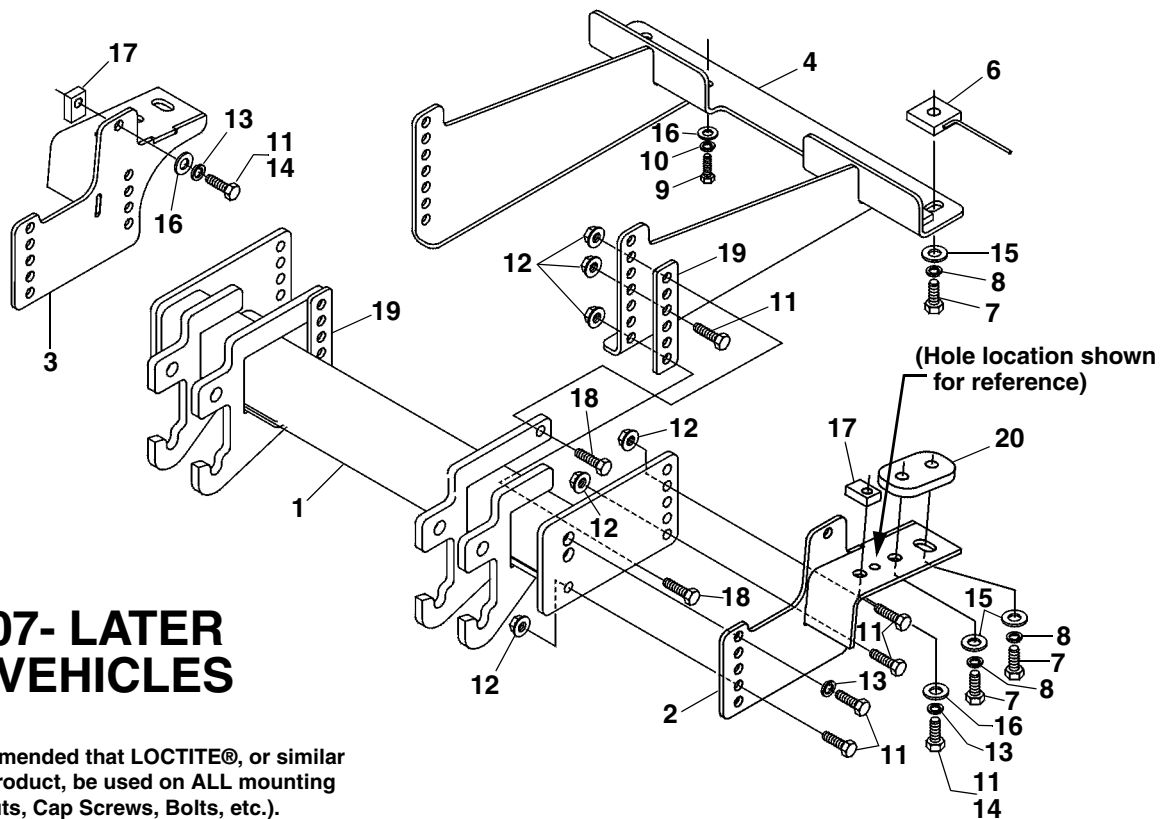

FOR: 07- LATER VEHICLES

Note: It is recommended that LOCTITE®, or similar thread locking product, be used on ALL mounting hardware (i.e. Nuts, Cap Screws, Bolts, etc.).

PARTS LIST

ITEM	PART NO.	DESCRIPTION	QTY.
1	99100892	Vehicle Center Member (96108919).....	1
2	96110326*	Front Mtg Weldment, LH.....	1
3	96110327*	Front Mtg Weldment, RH.....	1
4	96110331*	Crossmember Rear Weldment.....	1
5	96103813*	Nut Plate.....	2
6	96103518*	Rear Nut Plate.....	2
7	98009115	Hex Head Cap Screw, 5/8"-11 z 1-1/2".....	6
8	98009062	Lock Washer, 5/8".....	6
9	98009060	Hex Head Cap Screw, M10-1.5 x 35mm.....	2
10	98100050	Lock Washer, M10.....	2
11	98009010	Hex Head Cap Screw, 1/2"-13 x 1-1/2".....	12
12	98009013	Nylock Nut, 1/2"-13.....	12
13	98009012	Lock Washer, 1/2".....	6
14	98100309	Hex Head Cap Screw, M12-1.75 x 40mm.....	4
15	98009039	Flat Washer, 5/8".....	6
16	98009011	Flat Washer, 1/2".....	6
17	96103505*	Nut Plate.....	4
18	98100095	Hex Head Cap Screw, 1/2"-13 x 1-3/4".....	4
19	96109309	Spacer Plate.....	2
20	96111845	Nut Plate.....	2

* Not Available As a Service Part

SNO-WAY® INTERNATIONAL, INC.



Hartford, WI 53027 USA
Website: www.snoway.com
©2008 Sno-Way® International