

SNO-WAY®

SNOW & ICE CONTROL EQUIPMENT

ASSEMBLY & INSTALLATION INSTRUCTIONS

**FOR
SUBFRAME COMPONENTS 99100690**

**TO FIT
2004 - LATER CHEVROLET COLORADO 4x4
2004 - LATER GMC CANYON 4x4**

Sno-Way®, Down Pressure® and EIS® are registered trademarks of Sno-Way International, Inc.
ProControl™, MegaBlade™, V-Wing™, E-Z Switch™, Revolution™, MaxAdjust™, SpeedLock™, and QuickJack™
are trademarks of Sno-Way International, Inc.

©2010 Sno-Way® International

97100987C



1. THINK SAFETY, ALWAYS WEAR SAFETY GLASSES WHEN PERFORMING THE OPERATIONS PRESCRIBED IN THESE INSTRUCTIONS
2. READ ALL INSTRUCTIONS CAREFULLY BEFORE ATTEMPTING INSTALLATION
3. BEFORE BEGINNING WORK MAKE SURE TO SET PARKING BRAKE AND CHOCK WHEELS



MINIMUM VEHICLE RECOMMENDATIONS

Heavy Duty Alternator Heavy Duty Battery
 Manufacturers Snow Plow Package

ASSEMBLY TOOLS NEEDED

Impact Sockets 7/16" – 1-1/8"
 Impact Sockets Metric 10mm – 19mm
 Wrenches 7/16" – 1-1/8"
 Torque Wrench

NOTE: On some vehicles it may be necessary to use a form of load booster to decrease the vehicle's front suspension sag with the snow plow in place. This can be accomplished with the use of supplementary air bags, booster springs, or similar load boosting devices. Since there are different load boosting devices available, it will up to the customer/end user to decide and purchase the product to suit the application, and not the responsibility of Sno-Way International, Inc.

INSTALLATION NOTES

1. Unless otherwise specified, mount all Subframe components to vehicle before tightening any hardware.
2. It is recommended that LOCTITE®, or similar thread locking product, be used on ALL mounting hardware (i.e. Nuts, Cap Screws, Bolts, etc.).
3. Vehicle should be parked on a level surface with a normal vehicle load on the FRONT suspension.
4. Items in parentheses () refer to quantity required for this step. Items in parentheses with a pound sign (#) indicate the part number as found in the parts list on the last page of this document.
 Example: (2) 1/2" x 1-1/2" Cap Screws (#5).
5. It maybe necessary to relocate license plate holder. Relocate under the driver's side headlight by drilling new holes in the bumper. Check state and local laws for placement, if needed.

MOUNTING INSTRUCTIONS

For most applications, removal of the bumper is not needed. However, In order to install the Mounting Assembly (#1) without removing the bumper, you will have to cut the bottom fascia (air dam) for clearance.

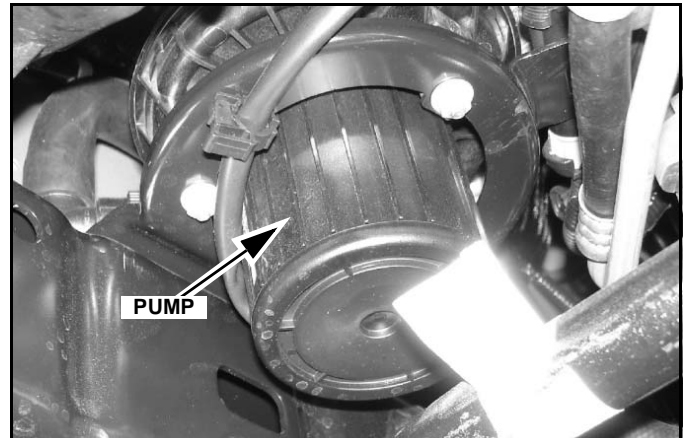

1. Some vehicles are equipped with a pump that mounts to the inside of the passenger frame rail. The bracket for this pump is fastened to the outside of the frame rail with two metric fasteners. If this is the case with your vehicle you must modify the Side Mounting Assembly, RH (#3). If the vehicle does not have the pump, proceed to step 3.

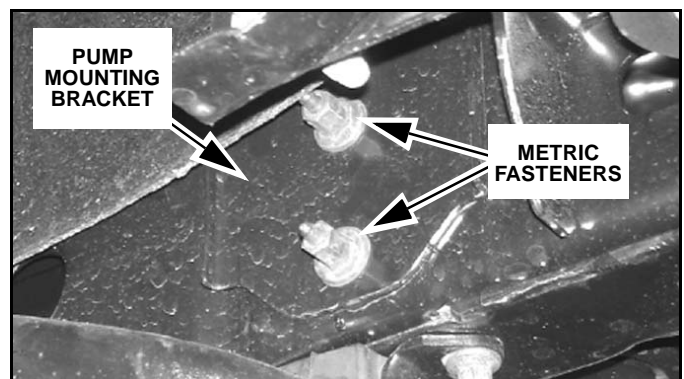

2. Remove the two metric fasteners that secure the pump mounting bracket to the outside of the passenger frame rail. Install the Side Mounting Assembly, RH (#3) per step 3. Center punch the bottom pump bracket bolt hole to the Side Mounting Assembly, RH (#3). Remove the Side Mounting Assembly, RH (#3) and drill a clearance hole for the pump mounting

bracket bolt size. Loosely install the bracket temporarily using only the bottom screw. In step 4 you will be drilling a 17/32" hole in this bracket to complete the sub-frame installation.

- Align the front top hole of a Side Mounting Assembly (LH, #2 or RH, #3) with existing hole in the vehicle frame. Use (1) 1/2"-13 x 4" Hex Cap Screw (#8) and a clamp to temporarily secure the Side Mounting Assembly to the frame rail. The Side Mounting Assembly should be positioned at the outside of the frame rail and the flange with the single hole should be under the frame rail. Center punch the rear top and bottom holes into the frame rail.
- Using the rear top hole in the Side Mounting Assembly as a template, drill a 1/4" pilot hole through both sides of the frame rail (NOTE: When equipped with a pump mounting bracket, the Side Mounting Assembly, RH (#3) hole will go through the pump mounting bracket). Next drill a 1/4" pilot hole through both sides of the frame rail in the bottom of the vehicle frame. Finish drill both of these holes to 17/32". Remove hardware.

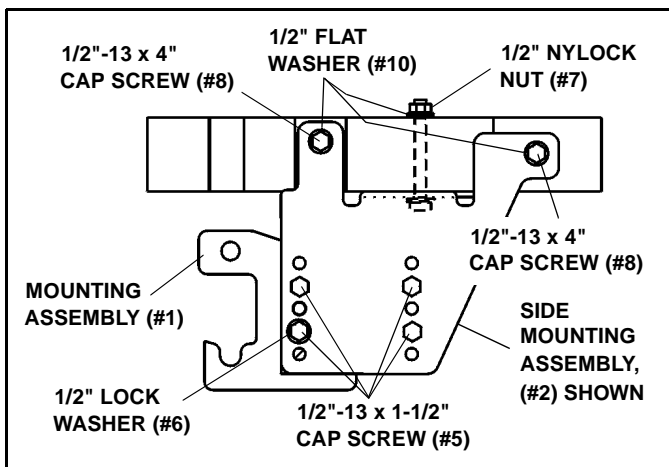

- Secure the Side Mounting Assembly loosely to the frame rail, installing (2) 1/2" x 4" Cap Screws (#8) and (2) 1/2" Flat Washers (#10) from the outside and securing at the inside of the frame rail with (2) Shim Plates (#4) and (2) 1/2" Nylock Nuts (#7).

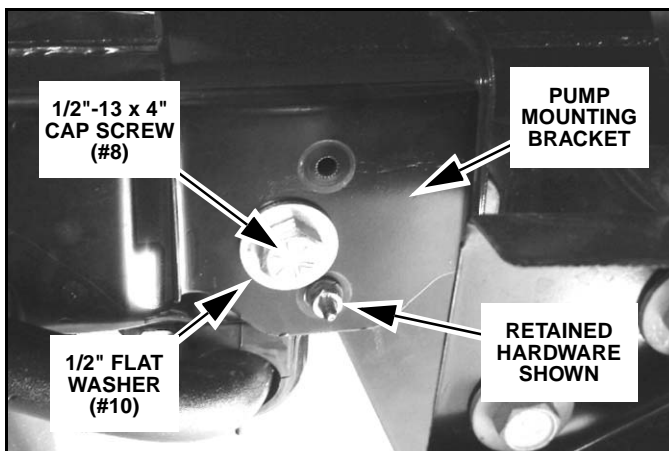

NOTE: Side Mounting Assembly RH (#3) installs under the pump mounting plate.

- Install (1) 1/2"-13 x 5" Cap Screw (#9) and (1) 1/2" Flat Washer (#10) from the bottom, through the flange and the frame rail, securing with (1) 1/2" Flat Washer (#10) and (1) 1/2" Nylock Nut (#7). Do not tighten at this time.
- Repeat procedure for other Side Mounting Assembly.
- Install the Mounting Assembly (#1) using (8) 1/2"-13 X 1-1/2" Cap Screws (#5), (2) 1/2" Lock Washers (#6) (for the threaded holes) and (6) 1/2" Nylock Nuts (#7).

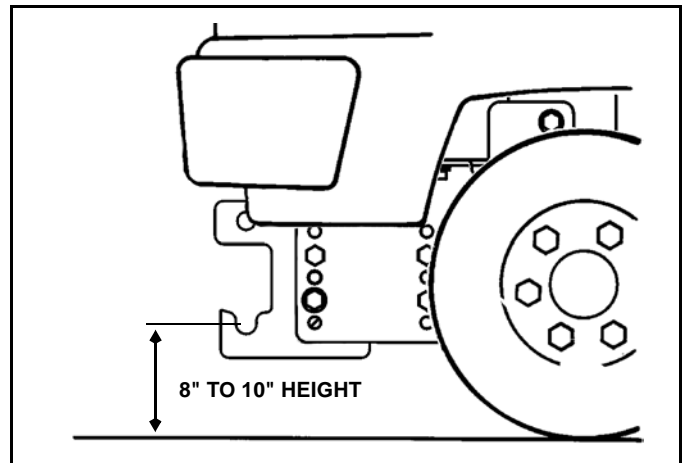

IMPORTANT: Height from the center of the lower Plow mounting holes on the Subframe to the ground should be between 8" and 10" to insure proper operation.

- Using the Torque Specification Chart provided, torque all Cap Screws.

TORQUE SPECIFICATIONS FOR STANDARD MACHINE HARDWARE					
Bolt Size	GR.2 Dry	GR.5 Dry	GR.8 Dry	Metric Size	GR.8.8 Dry
1/4"	66*	9	12	M8	17
5/16"	11	17	25	M10	35
3/8"	20	30	45	M12	60
7/16"	32	50	70	M14	95
1/2"	50	75	110	M16	155
9/16"	70	110	150		
5/8"	100	150	220		
3/4"	175	260	380		
7/8"	170	430	600		
1"	250	640	900		

These torque values are to be used for all hardware. Unless otherwise specified, all torque values must meet this specification.
All torque values are in Ft.-Lbs unless otherwise stated
*In-Lbs

REMEMBER After 5 to 10 hours of snowplow usage, re-torque all Cap Screws!

PARTS LIST

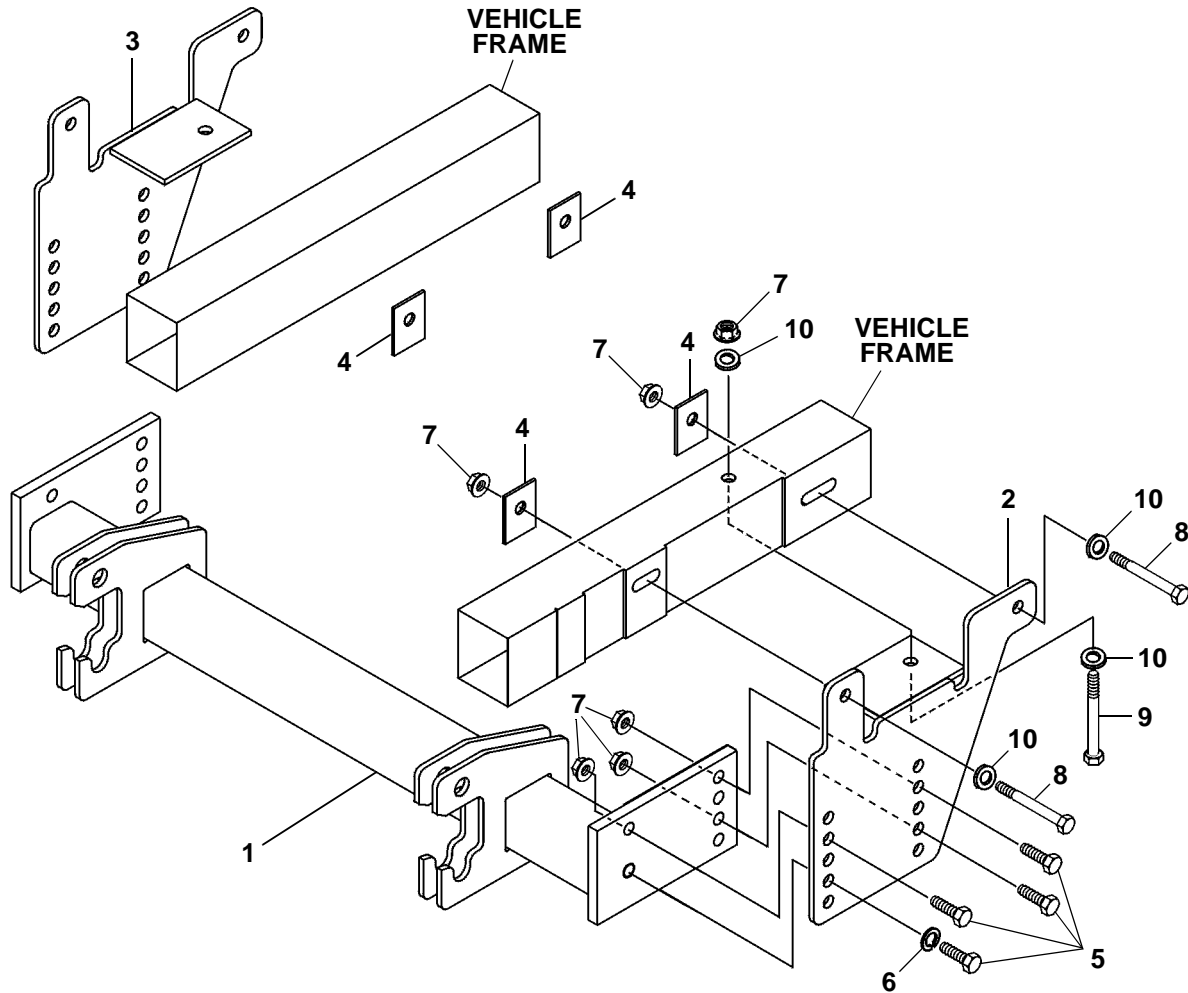

Note: It is recommended that LOCTITE®, or similar thread locking product, be used on ALL mounting hardware (i.e. Nuts, Cap Screws, Bolts, etc.).

ITEM	PART NO.	DESCRIPTION	QTY.
1	96107391	Mounting Assembly.....	1
2	96106923	Side Mounting Assembly, LH.....	1
3	96106924	Side Mounting Assembly, RH.....	1
4	96103283	Plate, Shim.....	4
5	98009010	Cap Screw, Hex head, 1/2"-13 x 1-1/2".....	8
6	98009012	Washer, Lock, 1/2".....	2
7	98009013	Nut, Hex Nylock, 1/2".....	12
8	98009195	Cap Screw, Hex Head, 1/2"-13 x 4".....	4
9	98009043	Cap Screw, Hex Head, 1/2"-13 x 5".....	2
10	98009011	Washer, Flat, 1/2".....	8

SNO-WAY® INTERNATIONAL, INC.

SNO-WAY
SNOW & ICE CONTROL EQUIPMENT

Hartford, WI 53027 USA
Website: www.snoway.com
©2010 Sno-Way® International